

AN5138NK

Video IF Amplifier, PLL Detector, AGC, AFC, SIF IC for Color TV

■ Overview

The AN5138NK is an integrated circuit designed for video-IF and audio-IF processing circuits, in color TV and VCR.

■ Features

- By adopting built-in VCO PLL-type video-detector circuit, the high performance IC-detector system can be realized for sound multiplex and tele-text broadcasting.
- Quadrature sound FM detector built-in.
- Frequency characteristics compensation pin (Pin20)
- VCR-switch pin (Pin5)
- Sound-output level-adjustment pin (Pin25)

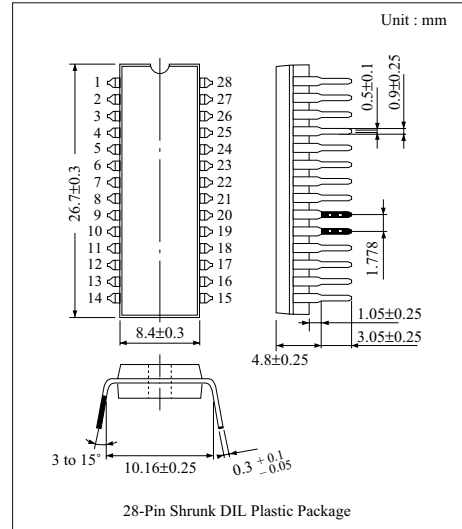

■ Block Diagram

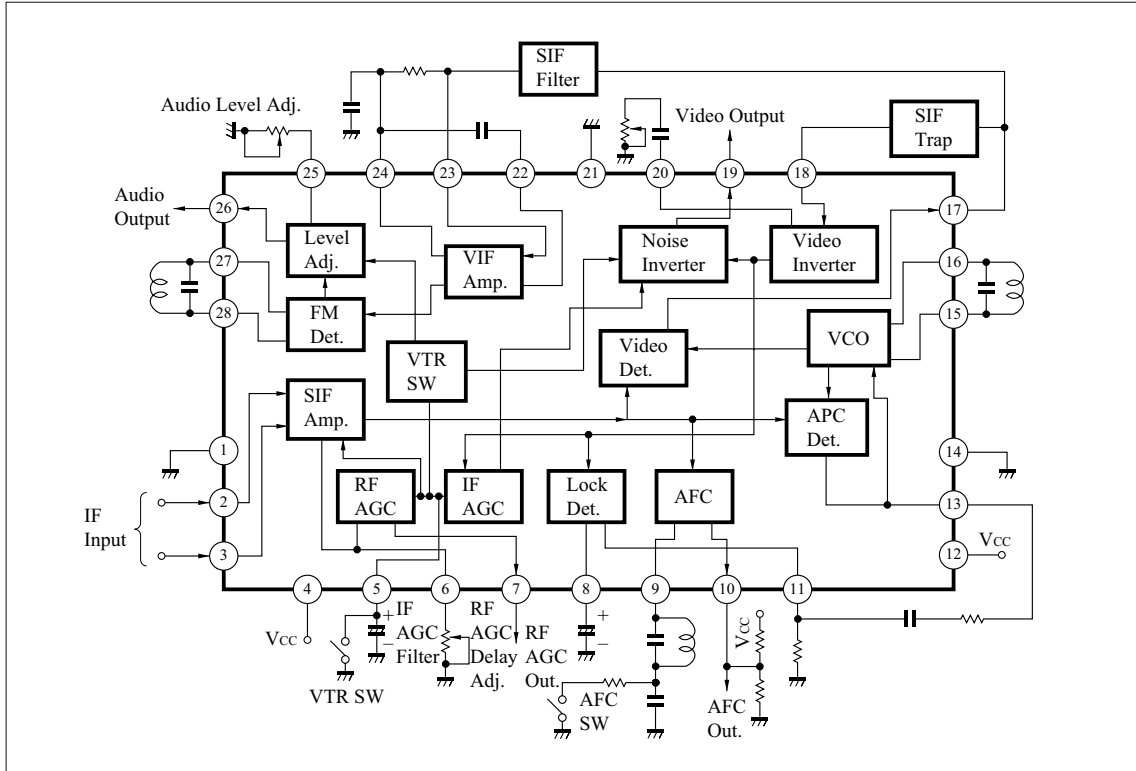

■ Absolute Maximum Ratings (Ta=25°C)

Parameter		Symbol	Rating		Unit
Voltage	Supply Voltage	V _{CC}	13.8		V
	Circuit Voltage	V _{5-1, 14, 21}	V _{4, 12-1, 14, 21}	0	V
		V _{6-1, 14, 21}	V _{4, 12-1, 14, 21}	0	V
		V _{7-1, 14, 21}	V _{4, 12-1, 14, 21}	0	V
		V _{10-1, 14, 21}	V _{4, 12-1, 14, 21}	0	V
		V _{18-1, 14, 21}	V _{4, 12-1, 14, 21}	0	V
		V _{25-1, 14, 21}	8.0	0	V
Current	Circuit Current	I ₁₇	-7	+0.5	mA
		I ₁₉	-7	+0.5	mA
		I ₂₆	-5	+0.5	mA
Power Dissipation (Ta=70°C)		P _D	1,300		mW
Temperature	Operating Ambient Temperature	T _{opr}	-20 to +70		°C
	Storage Temperature	T _{stg}	-55 to +150		°C

■ Electrical Characteristics (V_{CC}=12V, Ta=25°C)

Parameter	Symbol	Condition	min	typ	max	Unit
IF Amplifier · Detection · AGC · AFC Circuit						
Video detector output	V _O	f=58.75MHz, V _i =80dBμ, m=87.5%	1.9	2.2	2.5	V _{P-P}
Input sensitivity	S _(IN)	V _O =-3dB	49	53	57	dBμ
Max. allowable input	V _{1(max.)}		103	108	—	dBμ
Differential gain	DG	f=58.75MHz, V _i =80dBμ, m=87.5%	—	2	6	%
Differential phase	DP	f=58.75MHz, V _i =80dBμ, m=87.5%	—	2	5	deg
Frequency characteristics	f _c	V _O =-3dB	5.5	6.5	7.5	MHz
RF AGC gain	G _{RFAGC}	f=10kHz, V _i =10mV	40	44	48	dB
AFC phase det. sensitivity	μ	R _L =68kΩ/82kΩ	30	45	60	mV/kHz
AFC center voltage	V ₁₀	R _L =68kΩ/82kΩ	4.2	6.5	8.2	V
VCO · APC Circuit						
VCO max. variable range (1)	Δf _{V(1)}	V ₁₃ =2V	0.8	1.5	2.5	MHz
VCO max. variable range (2)	Δf _{V(2)}	V ₁₃ =3V	-3.4	-2.4	-1.4	MHz
VCO control sensitivity	β		3	4.5	6	kHz/mV
APC pull-in range (1)	f _{APC(1)}		+0.85	+1.5	+2.5	MHz
APC pull-in range (2)	f _{APC(2)}		-3.5	-2.5	-1.6	MHz
SIF Circuit						
Total detector output	V _O	f _o =4.5MHz, f _m =400Hz Δf=±25kHz, V _i =100dBμ	490	620	950	mV _{rms}
Input limiting voltage	V _{i(lim)}	f _o =4.5MHz, f _m =400Hz Δf=±25kHz, V _i =100dBμ	—	42	47	dBμ
DC Characteristics						
Circuit current	I ₄ + I ₁₂		50	70	90	mA

