

Silicon NPN Power Transistors

2SD1585

DESCRIPTION

- With TO-220Fa package
- V_{CEO} 60V; V_{EBO} 7V; $I_{C(DC)}$ 3.0A
- Complement to type 2SB1094

APPLICATIONS

- For use in audio frequency power amplifier and general purpose applications

PINNING

PIN	DESCRIPTION
1	Base
2	Collector
3	Emitter

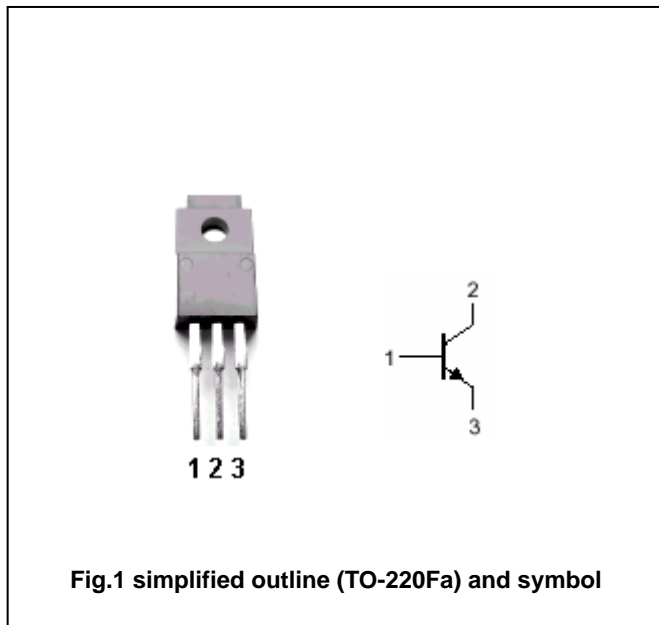

Absolute maximum ratings($T_a=25^\circ C$)

SYMBOL	PARAMETER	CONDITIONS	VALUE	UNIT
V_{CBO}	Collector-base voltage	Open emitter	60	V
V_{CEO}	Collector-emitter voltage	Open base	60	V
V_{EBO}	Emitter-base voltage	Open collector	7	V
I_C	Collector current		3	A
I_{CM}	Collector current-Peak		5	A
I_B	Base current		0.6	A
P_C	Collector power dissipation	$T_a=25$	2.0	W
		$T_C=25$	15	
T_j	Junction temperature		150	
T_{stg}	Storage temperature		-55~150	

Silicon NPN Power Transistors

2SD1585

CHARACTERISTICS

T_j=25 unless otherwise specified

SYMBOL	PARAMETER	CONDITIONS	MIN	TYP.	MAX	UNIT
V _{(BR)CEO}	Collector-emitter breakdown voltage	I _C =30mA; I _B =0	60			V
V _{CEsat}	Collector-emitter saturation voltage	I _C =2A; I _B =0.2A			1.5	V
V _{BEsat}	Base-emitter saturation voltage	I _C =2A; I _B =0.2A			2.0	V
I _{CBO}	Collector cut-off current	V _{CB} =60V; I _E =0			10	μA
I _{EBO}	Emitter cut-off current	V _{EB} =7V; I _C =0			10	μA
h _{FE-1}	DC current gain	I _C =50mA; V _{CE} =5V	20			
h _{FE-2}	DC current gain	I _C =0.5A; V _{CE} =5V	40		200	
f _T	Transition frequency	I _C =0.1A; V _{CE} =5V		16		MHz
C _{OB}	Collector output capacitance	f=1MHz; V _{CB} =10V		48		pF

◆ h_{FE-2} Classifications

M	L	K
40-80	60-120	100-200

PACKAGE OUTLINE

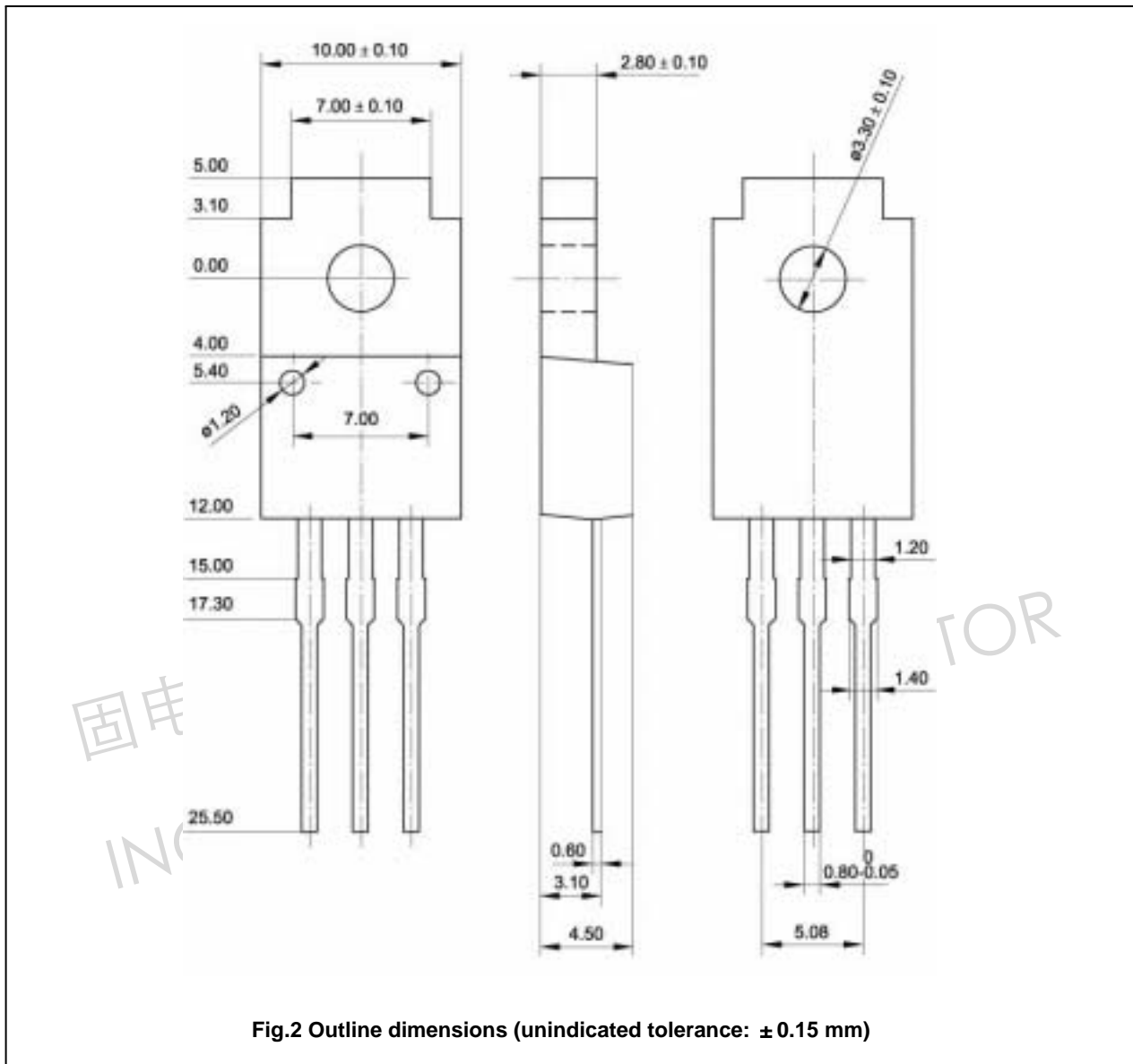

Fig.2 Outline dimensions (unindicated tolerance: ± 0.15 mm)