

STK6820, 6820H SERIES

BIPOLAR TYPE STEPPING MOTOR DRIVER
(バイポーラタイプステッピングモータドライバ)

△ Under development

Type No. 機種	Maximum Rating 最大定格				Recommended Condition 推奨条件	Main Operational Characteristics 動作特性					
	V _{cc} max	I _o max	T _c max	T _j max		V _{cc}	Output Saturation 出力飽和電圧			OSC Frequency 発振周波数	Thermal resistance (θ _{j-c}) 接合部熱抵抗
	V	A	°C	°C	V		V _{st1} V	V _{st2} V	I _{OH} A		KHz
△ STK6820	30	0.7	105	150	24	1.0	2.0	0.43	24	11.0	19.2
△ STK6821	30	1.5	105	150	24	1.0	2.3	0.9	24	10.0	16.0
△ STK6822	30	2.5	105	150	24	1.2	2.5	1.5	24	9.0	13.5
△ STK6820H	52	0.7	105	150	36	1.0	2.0	0.43	24	11.0	19.2
△ STK6821H	52	1.5	105	150	36	1.0	2.3	0.9	24	10.0	16.0
△ STK6822H	52	2.5	105	150	36	1.2	2.5	1.5	24	8.5	13.5

■ EQUIVALENT CIRCUIT

(1)

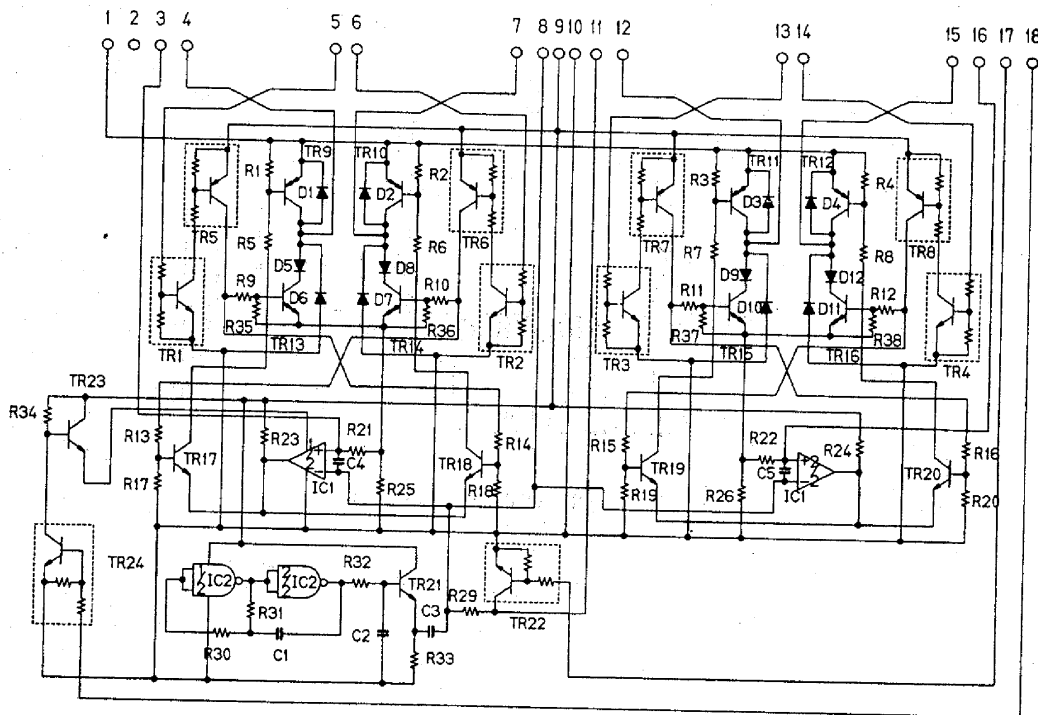

STK6820series

(2)

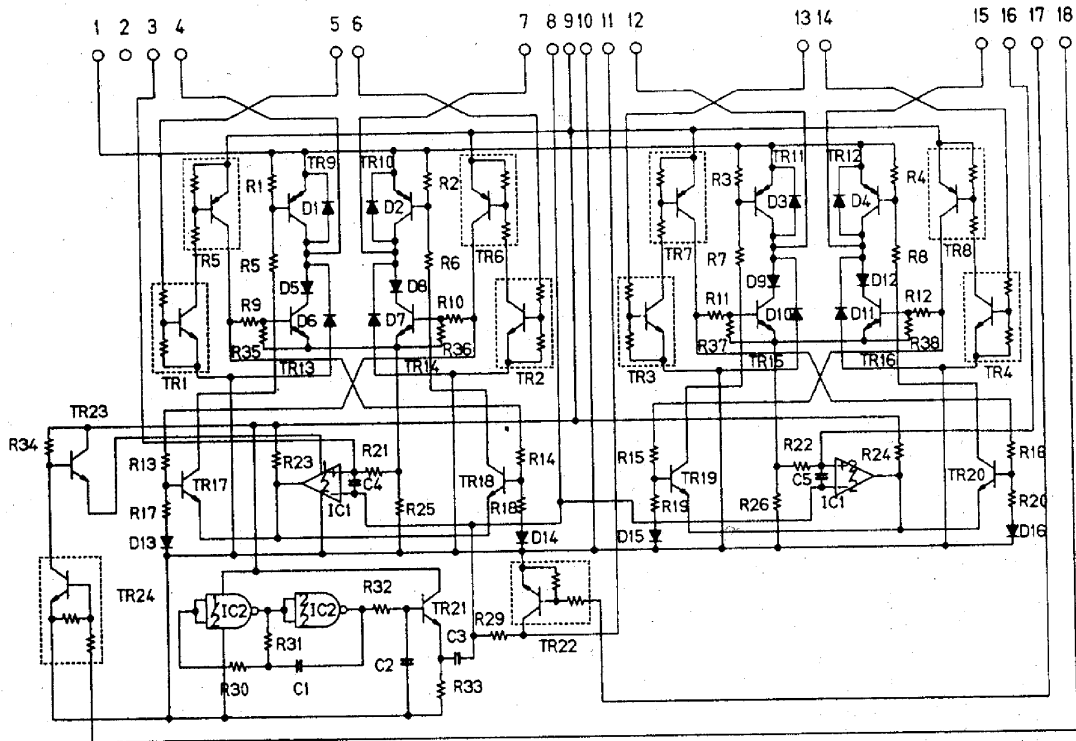

STK6820Hseries

■ PACKAGE DIMENSION

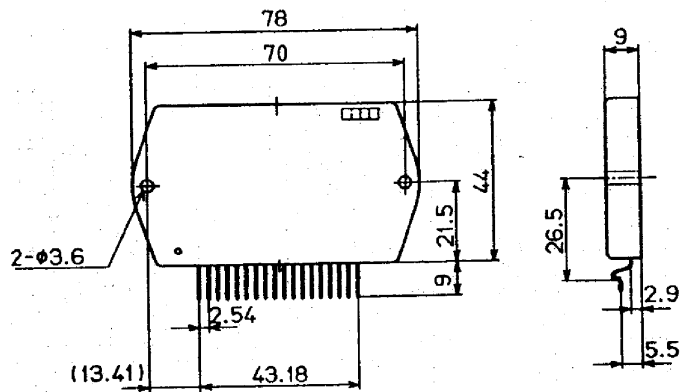

(STK6820,6820H series)