

# 7-channel Darlington transistor array

## BA6250/BA6250F/BA6251/BA6251F

The BA6250, BA6250F, BA6251, and BA6251F are 7-channel transistor arrays particularly suitable for interfaces between a microcomputer in a VTR and the various ICs, or between one IC and another, and for low current drives such as LEDs.

### ●Features

- 1) High withstanding output voltage of 30V (max.).
- 2) Output current of 20mA max. ( $V_{IN} \geq 3V$ ).

### ●Internal circuit configuration diagram

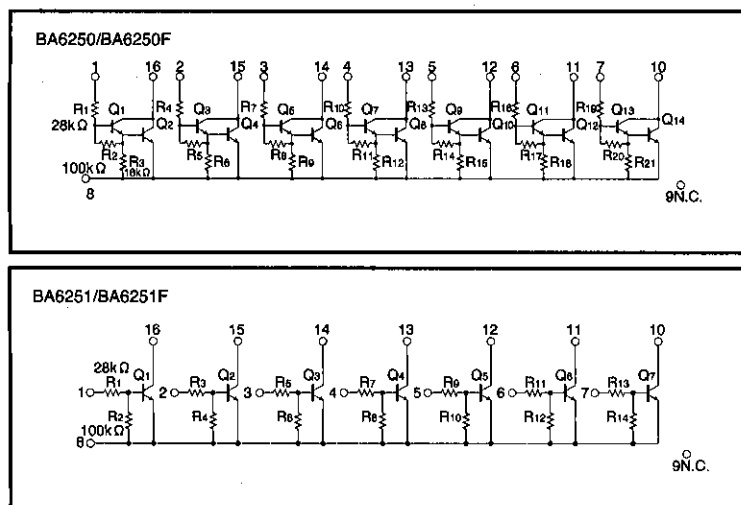

### ●Block diagram

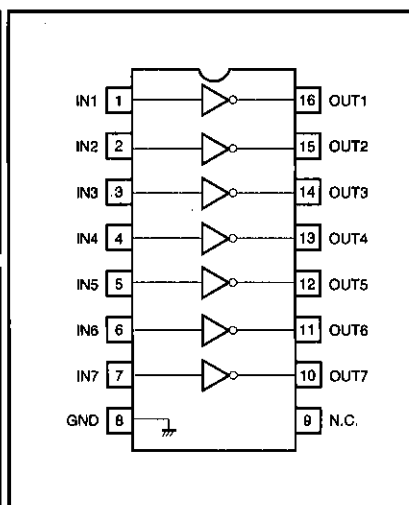

### ●Absolute maximum ratings ( $T_a=25^\circ\text{C}$ )

Parameter	Symbol	Limits	Unit
Power supply voltage	$V_{CE0}$	30	V
Power dissipation	$P_d$	500 *	mW
Operating temperature	$T_{opr}$	$-25 \sim 75$	$^\circ\text{C}$
Storage temperature	$T_{stg}$	$-55 \sim 125$	$^\circ\text{C}$
Input voltage	$V_{IN}$	30	V
Output current	$I_{O\ Max.}$	30	mA

\* Reduced by 5mW for each increase in  $T_a$  of  $1^\circ\text{C}$  over  $25^\circ\text{C}$ .

●Electrical characteristics (unless otherwise noted, Ta=25°C, Vcc=12V)

Parameter	Symbol	Type	Min.	Typ.	Max.	Unit	Conditions	Measurement Circuit
Output power supply voltage range	Vo	BA6250 / BA6250F	—	12	28	V	—	Fig. 1
		BA6251 / BA6251F	—	12	28		—	
"H" input voltage	V <sub>IH</sub>	BA6250 / BA6250F	3	—	—	V	I <sub>OUT</sub> =20mA	Fig. 1
		BA6251 / BA6251F	2	—	—		I <sub>OUT</sub> ≥1mA	
"L" input voltage	V <sub>IL</sub>	BA6250 / BA6250F	—	—	0.6	V	I <sub>OUT</sub> ≤10 μA	Fig. 2
		BA6251 / BA6251F	—	—	0.3		I <sub>OUT</sub> ≤10 μA	
Output voltage	V <sub>OUT</sub>	BA6250 / BA6250F	—	—	1.4	V	I <sub>OUT</sub> =20mA, V <sub>IN</sub> =12V	Fig. 1
Output saturation voltage	V <sub>CE (sat)</sub>	BA6251 / BA6251F	—	0.3	—		I <sub>OUT</sub> =10mA, V <sub>IN</sub> =12V	
Output current	I <sub>OUT</sub>	BA6250 / BA6250F	—	—	20	mA	V <sub>IN</sub> ≥3V	Fig. 1
		BA6251 / BA6251F	—	—	20		V <sub>IN</sub> ≥12V	
Input current	I <sub>IN</sub>	BA6250 / BA6250F	—	—	0.6	mA	I <sub>OUT</sub> =10mA, V <sub>IN</sub> =12V	Fig. 1
		BA6251 / BA6251F	—	—	0.6		I <sub>OUT</sub> =10mA, V <sub>IN</sub> =12V	
Output leakage current	I <sub>L</sub>	BA6250 / BA6250F	—	—	1	μA	V <sub>CC</sub> =28V, V <sub>IN</sub> =0V	—

●Measurement circuits

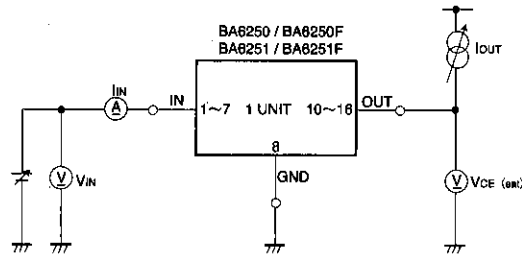

Fig.1

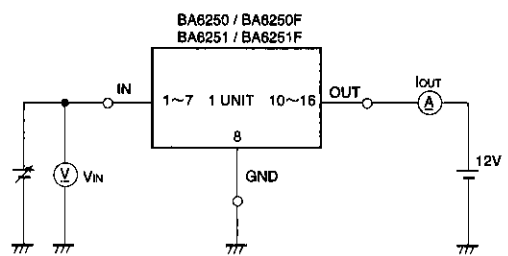

Fig.2

●External dimensions (Units: mm)

