

TOSHIBA CMOS Digital Integrated Circuit Silicon Monolithic

TC74HC564AP, TC74HC564AF TC74HC574AP, TC74HC574AF, TC74HC574AFW

Octal D-Type Flip-Flop with 3-State Output

TC74HC564AP/AF Inverting

TC74HC574AP/AF/AFW Non-Inverting

Note: xxxFW (JEDEC SOP) is not available in Japan.

The TC74HC564A and HC574A are high speed CMOS OCTAL FLIP-FLOPs with 3-STATE OUTPUT fabricated with silicon gate C²MOS technology.

They achieve the high speed operation similar to equivalent LSTTL while maintaining the CMOS low power dissipation.

These 8-bit D-type flip-flops are controlled by a clock input (CK) and an output enable input (\overline{OE}).

The TC74HC564A has inverting outputs, and the TC74HC574A has non-inverting outputs.

All inputs are equipped with protection circuits against static discharge or transient excess voltage.

Features

- High speed: $f_{max} = 62$ MHz (typ.) at $V_{CC} = 5$ V
- Low power dissipation: $I_{CC} = 4$ μ A (max) at $T_a = 25^\circ\text{C}$
- High noise immunity: $V_{NIH} = V_{NIL} = 28\%$ V_{CC} (min)
- Output drive capability: 15 LSTTL loads
- Symmetrical output impedance: $|I_{OH}| = I_{OL} = 6$ mA (min)
- Balanced propagation delays: $t_{pLH} \approx t_{pHL}$
- Wide operating voltage range: $V_{CC} (opr) = 2$ to 6 V
- Pin and function compatible with 74LS564/574

TC74HC564AP, TC74HC574AP

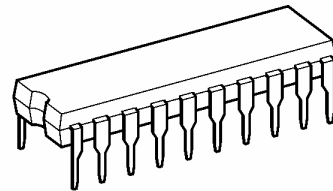

DIP20-P-300-2.54A

TC74HC564AF, TC74HC574AF

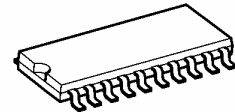

SOP20-P-300-1.27A

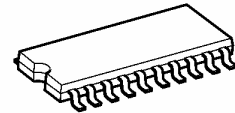

SOP20-P-300-1.27

TC74HC574AFW

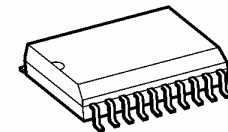

SOL20-P-300-1.27

Weight

DIP20-P-300-2.54A	: 1.30 g (typ.)
SOP20-P-300-1.27A	: 0.22 g (typ.)
SOP20-P-300-1.27	: 0.22 g (typ.)
SOL20-P-300-1.27	: 0.46 g (typ.)

Pin Assignment

TC74HC564A

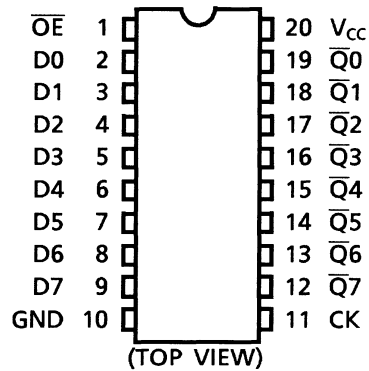

TC74HC574A

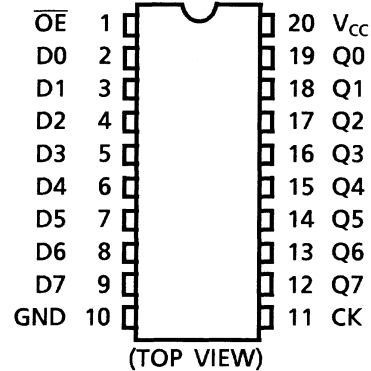

IEC Logic Symbol

TC74HC564A

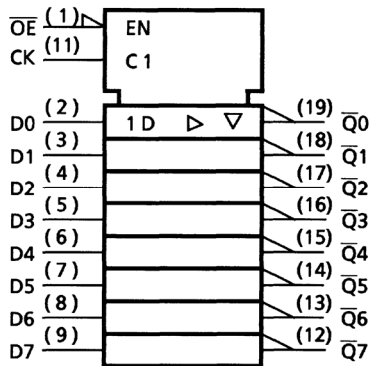

TC74HC574A

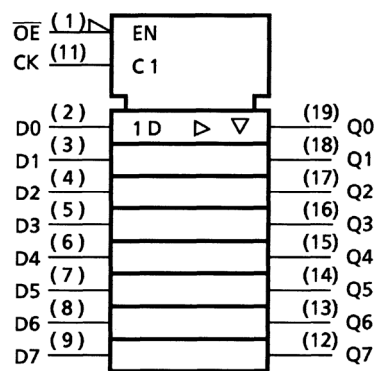

Truth Table

Inputs			Outputs	
\overline{OE}	CK	D	Q (574A)	\overline{Q} (564A)
H	X	X	Z	Z
L	\downarrow	X	Q_n	\overline{Q}_n
L	\uparrow	L	L	H
L	\uparrow	H	H	L

X: Don't care

Z: High impedance

Q_n (\overline{Q}_n): No change

System Diagram

TC74HC564A

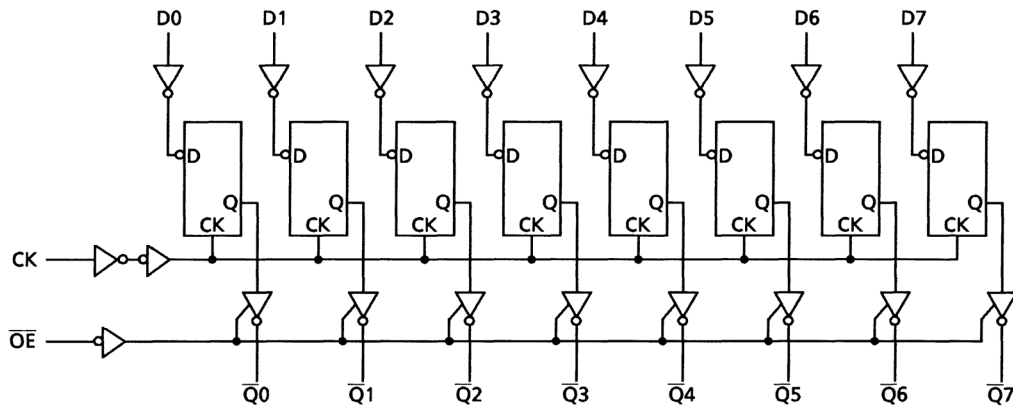

TC74HC574A

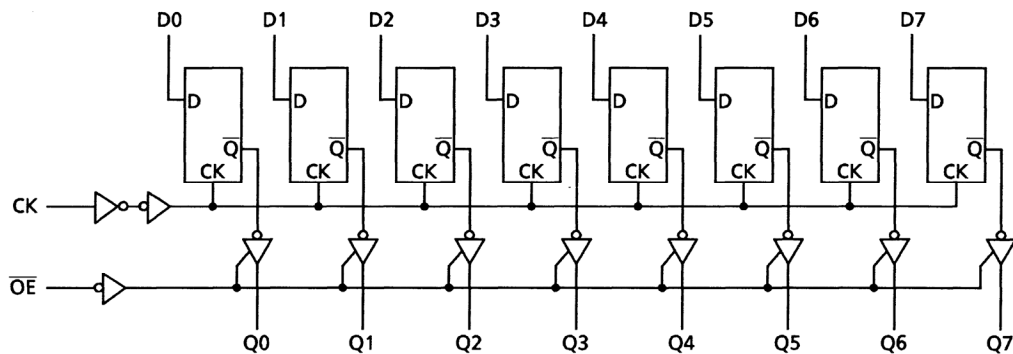

Absolute Maximum Ratings (Note 1)

Characteristics	Symbol	Rating	Unit
Supply voltage range	V_{CC}	-0.5 to 7	V
DC input voltage	V_{IN}	-0.5 to $V_{CC} + 0.5$	V
DC output voltage	V_{OUT}	-0.5 to $V_{CC} + 0.5$	V
Input diode current	I_{IK}	± 20	mA
Output diode current	I_{OK}	± 20	mA
DC output current	I_{OUT}	± 35	mA
DC V_{CC} /ground current	I_{CC}	± 75	mA
Power dissipation	P_D	500 (DIP) (Note 2)/180 (SOP)	mW
Storage temperature	T_{stg}	-65 to 150	$^{\circ}C$

Note 1: Exceeding any of the absolute maximum ratings, even briefly, lead to deterioration in IC performance or even destruction.

Note 2: 500 mW in the range of $T_a = -40$ to $65^{\circ}C$. From $T_a = 65$ to $85^{\circ}C$ a derating factor of -10 mW/ $^{\circ}C$ shall be applied until 300 mW.

Recommended Operating Conditions (Note)

Characteristics	Symbol	Rating	Unit
Supply voltage	V_{CC}	2 to 6	V
Input voltage	V_{IN}	0 to V_{CC}	V
Output voltage	V_{OUT}	0 to V_{CC}	V
Operating temperature	T_{opr}	-40 to 85	°C
Input rise and fall time	t_r, t_f	0 to 1000 ($V_{CC} = 2.0$ V) 0 to 500 ($V_{CC} = 4.5$ V) 0 to 400 ($V_{CC} = 6.0$ V)	ns

Note: The recommended operating conditions are required to ensure the normal operation of the device. Unused inputs must be tied to either VCC or GND.

Electrical Characteristics

DC Characteristics

Characteristics	Symbol	Test Condition	$T_a = 25^\circ\text{C}$			$T_a = -40$ to 85°C		Unit		
			V_{CC} (V)	Min	Typ.	Max	Min		Max	
High-level input voltage	V_{IH}	—	2.0	1.50	—	—	1.50	—	V	
			4.5	3.15	—	—	3.15	—		
			6.0	4.20	—	—	4.20	—		
Low-level input voltage	V_{IL}	—	2.0	—	—	0.50	—	0.50	V	
			4.5	—	—	1.35	—	1.35		
			6.0	—	—	1.80	—	1.80		
High-level output voltage	V_{OH}	$V_{IN} = V_{IH}$ or V_{IL}	$I_{OH} = -20 \mu\text{A}$	2.0	1.9	2.0	—	1.9	—	V
			$I_{OH} = -6 \text{ mA}$	4.5	4.4	4.5	—	4.4	—	
			$I_{OH} = -7.8 \text{ mA}$	6.0	5.9	6.0	—	5.9	—	
				4.5	4.18	4.31	—	4.13	—	
Low-level output voltage	V_{OL}	$V_{IN} = V_{IH}$ or V_{IL}	$I_{OL} = 20 \mu\text{A}$	2.0	—	0.0	0.1	—	0.1	V
			$I_{OL} = 6 \text{ mA}$	4.5	—	0.0	0.1	—	0.1	
			$I_{OL} = 7.8 \text{ mA}$	6.0	—	0.0	0.1	—	0.1	
				4.5	—	0.17	0.26	—	0.33	
	6.0	—	0.18	0.26	—	0.33				
3-state output off-state current	I_{OZ}	$V_{IN} = V_{IH}$ or V_{IL} $V_{OUT} = V_{CC}$ or GND	6.0	—	—	± 0.5	—	± 5.0	μA	
Input leakage current	I_{IN}	$V_{IN} = V_{CC}$ or GND	6.0	—	—	± 0.1	—	± 1.0	μA	
Quiescent supply current	I_{CC}	$V_{IN} = V_{CC}$ or GND	6.0	—	—	4.0	—	40.0	μA	

Timing Requirements (input: $t_r = t_f = 6 \text{ ns}$)

Characteristics	Symbol	Test Condition	Ta = 25°C			Ta = -40 to 85°C	Unit
			VCC (V)	Typ.	Limit	Limit	
Minimum pulse width (CK)	t_W (H)	—	2.0	—	75	95	ns
	t_W (L)		4.5	—	15	19	
			6.0	—	13	16	
Minimum set-up time (Dn)	t_s	—	2.0	—	75	95	ns
			4.5	—	15	19	
			6.0	—	13	16	
Minimum hold time (Dn)	t_h	—	2.0	—	0	0	ns
			4.5	—	0	0	
			6.0	—	0	0	
Clock frequency	f	—	2.0	—	6	5	MHz
			4.5	—	31	24	
			6.0	—	36	28	

AC Characteristics (input: $t_r = t_f = 6$ ns)

Characteristics	Symbol	Test Condition	Ta = 25°C			Ta = -40 to 85°C		Unit		
			CL (pF)	VCC (V)	Min	Typ.	Max		Min	Max
Output transition time	t_{TLH} t_{THL}	—	50	2.0	—	25	60	—	75	ns
				4.5	—	7	12	—	15	
				6.0	—	6	10	—	13	
Propagation delay time (CK-Q, \bar{Q})	t_{PLH} t_{PHL}	—	50	2.0	—	70	150	—	190	ns
				4.5	—	20	30	—	38	
				6.0	—	15	26	—	33	
			150	2.0	—	88	190	—	240	
				4.5	—	25	38	—	48	
				6.0	—	19	33	—	41	
Output enable time	t_{pZL} t_{pZH}	$R_L = 1$ k Ω	50	2.0	—	48	125	—	155	ns
				4.5	—	15	25	—	31	
				6.0	—	12	21	—	26	
			150	2.0	—	60	165	—	205	
				4.5	—	20	33	—	41	
				6.0	—	16	28	—	35	
Output disable time	t_{pLZ} t_{pHZ}	$R_L = 1$ k Ω	50	2.0	—	34	125	—	155	ns
				4.5	—	17	25	—	31	
				6.0	—	15	21	—	26	
Maximum clock frequency	f_{max}	—	50	2.0	6	17	—	5	—	MHz
				4.5	31	50	—	24	—	
				6.0	36	59	—	28	—	
Input capacitance	C_{IN}	—	—	—	5	10	—	10	pF	
Output capacitance	C_{OUT}	—	—	—	10	—	—	—	pF	
Power dissipation capacitance	C_{PD} (Note)	—	—	—	54	—	—	—	pF	

Note: C_{PD} is defined as the value of the internal equivalent capacitance which is calculated from the operating current consumption without load.

Average operating current can be obtained by the equation:

$$I_{CC}(\text{opr}) = C_{PD} \cdot V_{CC} \cdot f_{IN} + I_{CC}/8 \text{ (per bit)}$$

And the total C_{PD} when n pcs. of flip flop operate can be gained by the following equation:

$$C_{PD}(\text{total}) = 39 + 15 \cdot n$$

Package Dimensions

DIP20-P-300-2.54A

Unit : mm

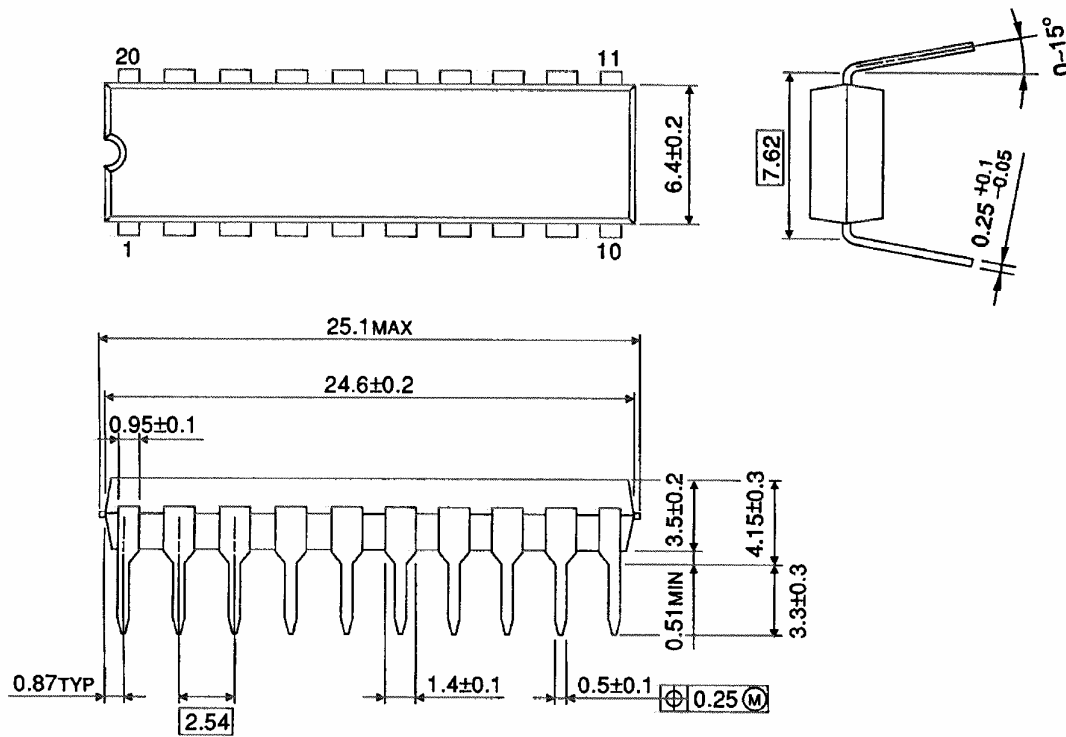

Weight: 1.30 g (typ.)

Package Dimensions

SOP20-P-300-1.27A

Unit: mm

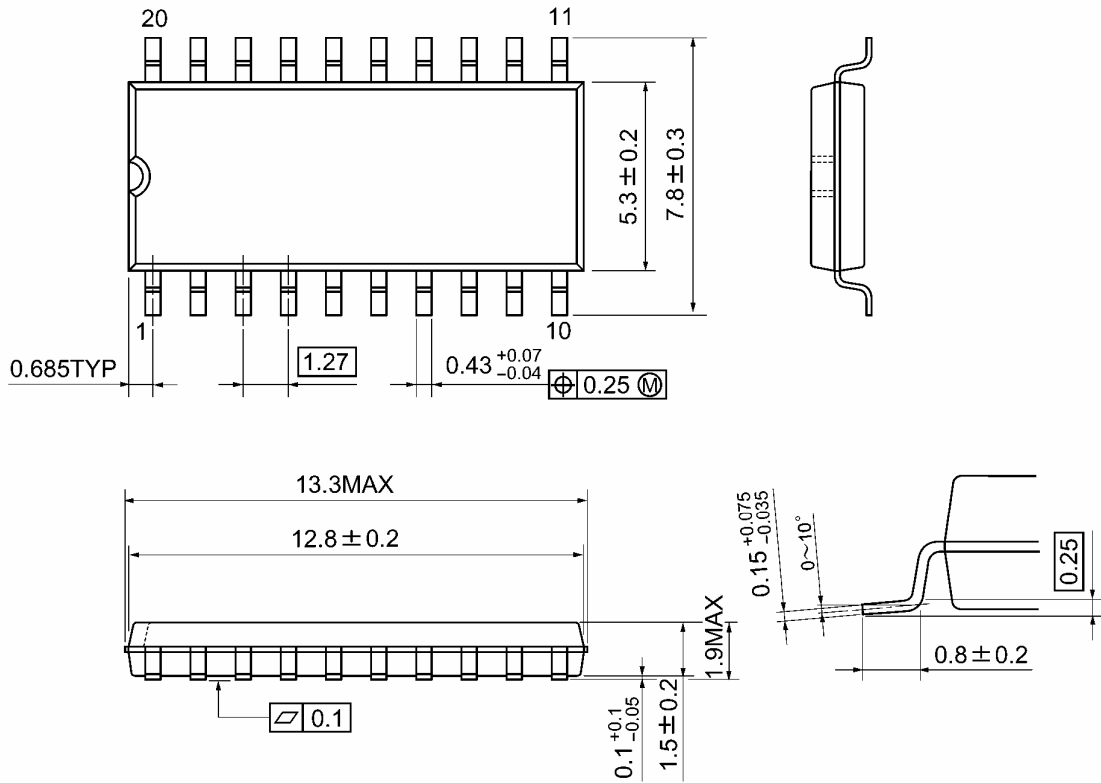

Weight: 0.22 g (typ.)

Package Dimensions

SOP20-P-300-1.27

Unit : mm

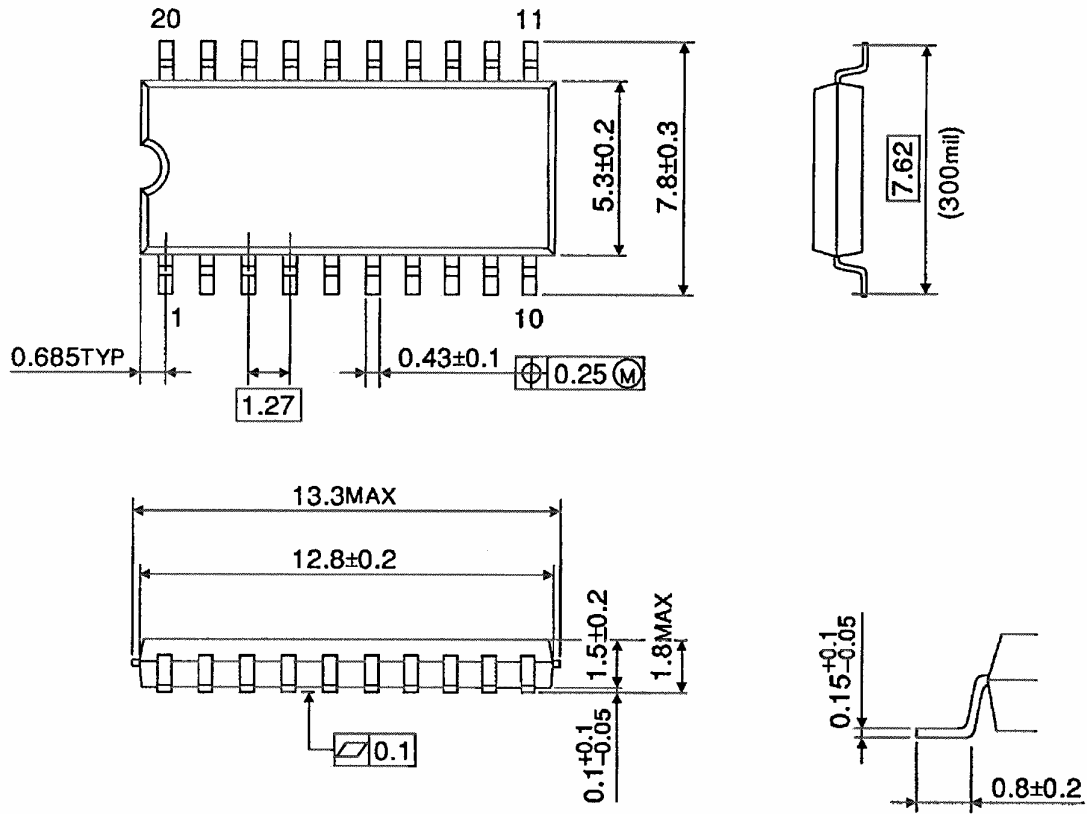

Weight: 0.22 g (typ.)

Package Dimensions (Note)

SOL20-P-300-1.27

Unit : mm

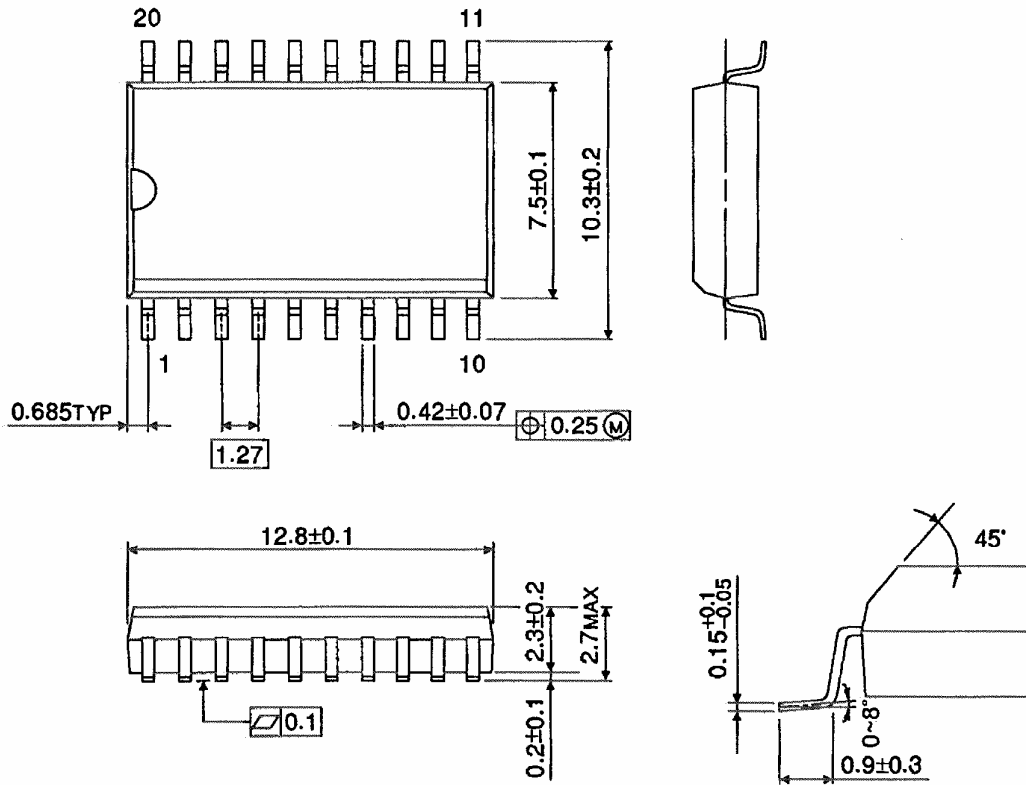

Note: This package is not available in Japan.

Weight: 0.46 g (typ.)

Note: Lead (Pb)-Free Packages

DIP20-P-300-2.54A SOP20-P-300-1.27A

RESTRICTIONS ON PRODUCT USE

060116EBA

- The information contained herein is subject to change without notice. 021023_D
- TOSHIBA is continually working to improve the quality and reliability of its products. Nevertheless, semiconductor devices in general can malfunction or fail due to their inherent electrical sensitivity and vulnerability to physical stress. It is the responsibility of the buyer, when utilizing TOSHIBA products, to comply with the standards of safety in making a safe design for the entire system, and to avoid situations in which a malfunction or failure of such TOSHIBA products could cause loss of human life, bodily injury or damage to property.
In developing your designs, please ensure that TOSHIBA products are used within specified operating ranges as set forth in the most recent TOSHIBA products specifications. Also, please keep in mind the precautions and conditions set forth in the "Handling Guide for Semiconductor Devices," or "TOSHIBA Semiconductor Reliability Handbook" etc. 021023_A
- The TOSHIBA products listed in this document are intended for usage in general electronics applications (computer, personal equipment, office equipment, measuring equipment, industrial robotics, domestic appliances, etc.). These TOSHIBA products are neither intended nor warranted for usage in equipment that requires extraordinarily high quality and/or reliability or a malfunction or failure of which may cause loss of human life or bodily injury ("Unintended Usage"). Unintended Usage include atomic energy control instruments, airplane or spaceship instruments, transportation instruments, traffic signal instruments, combustion control instruments, medical instruments, all types of safety devices, etc. Unintended Usage of TOSHIBA products listed in this document shall be made at the customer's own risk. 021023_B
- The products described in this document shall not be used or embedded to any downstream products of which manufacture, use and/or sale are prohibited under any applicable laws and regulations. 060106_Q
- The information contained herein is presented only as a guide for the applications of our products. No responsibility is assumed by TOSHIBA for any infringements of patents or other rights of the third parties which may result from its use. No license is granted by implication or otherwise under any patent or patent rights of TOSHIBA or others. 021023_C
- The products described in this document are subject to the foreign exchange and foreign trade laws. 021023_E