

Silicon NPN Power Transistors

2SD2293

DESCRIPTION

- With TO-3PN package
- High voltage
- Built-in damper diode

APPLICATIONS

- For color TV horizontal deflection output applications

PINNING

PIN	DESCRIPTION
1	Base
2	Collector;connected to mounting base
3	Emitter

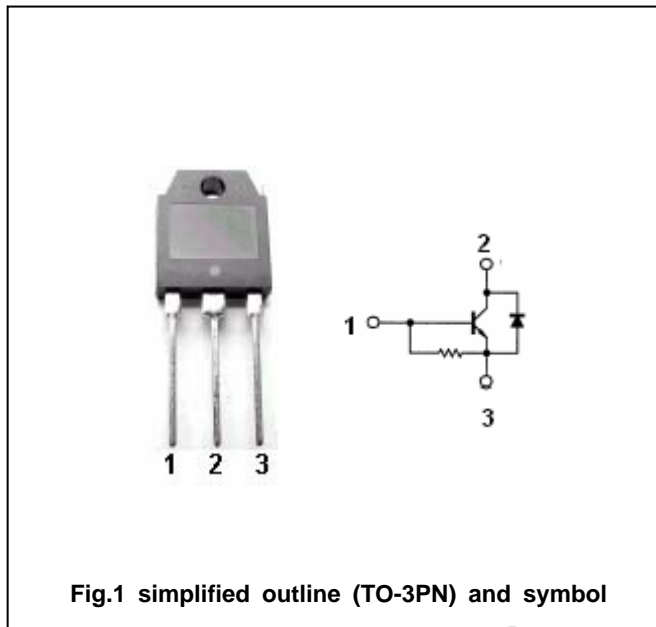

Fig.1 simplified outline (TO-3PN) and symbol

Absolute maximum ratings (Ta=25)

SYMBOL	PARAMETER	CONDITIONS	VALUE	UNIT
V_{CBO}	Collector-base voltage	Open emitter	1500	V
V_{CEO}	Collector-emitter voltage	Open base	700	V
V_{EBO}	Emitter-base voltage	Open collector	6	V
I_C	Collector current		3	A
P_C	Collector power dissipation	$T_C=25$	50	W
T_j	Junction temperature		150	
T_{stg}	Storage temperature		-55-150	

Silicon NPN Power Transistors

2SD2293

CHARACTERISTICS

T_j=25 unless otherwise specified

SYMBOL	PARAMETER	CONDITIONS	MIN	TYP.	MAX	UNIT
V _{CEO(SUS)}	Collector-emitter sustaining voltage	I _C =100mA; I _B =0	700			V
V _{EBO(BR)}	Emitter-base breakdown voltage	I _E =350mA; I _C =0	6			V
V _{CEsat}	Collector-emitter saturation voltage	I _C =2.5A; I _B =0.8A			5.0	V
V _{BEsat}	Base-emitter saturation voltage	I _C =2.5A; I _B =0.8A			1.5	V
h _{FE}	DC current gain	I _C =0.5A; V _{CE} =5V	8			
I _{CES}	Collector cut-off current	V _{CE} =1500V; V _{BE} =0			0.5	mA

固电半导体

INCHANGE SEMICONDUCTOR

Silicon NPN Power Transistors

2SD2293

PACKAGE OUTLINE

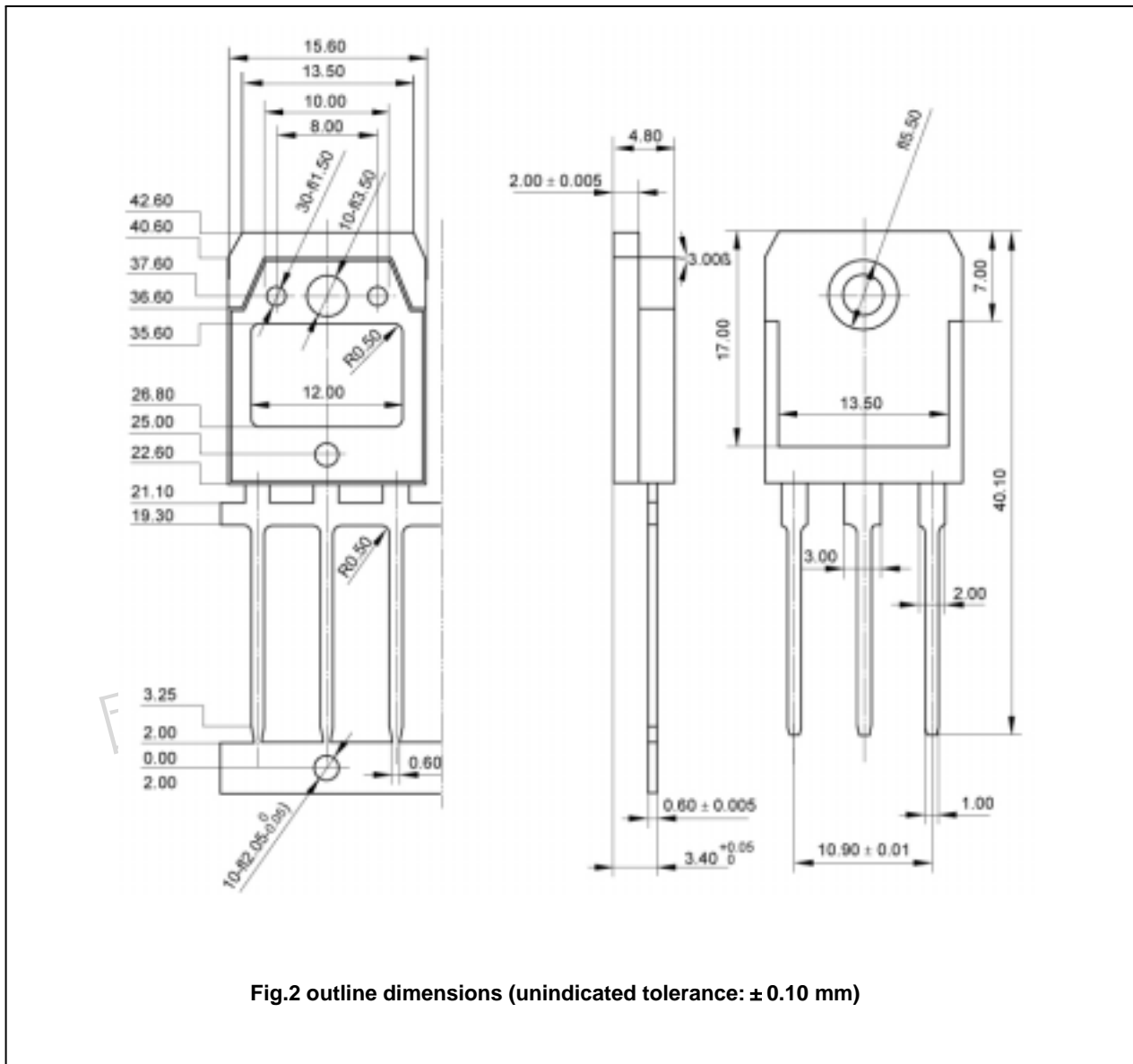

Fig.2 outline dimensions (unindicated tolerance: ± 0.10 mm)