

Silicon NPN Power Transistors

BU326 BU326A

DESCRIPTION

- With TO-3 package
- High voltage;high speed
- Low collector saturation voltage.

APPLICATIONS

- Intended for operating in CTV receiver's chopper supplies.

PINNING(see fig.2)

PIN	DESCRIPTION
1	Base
2	Emitter
3	Collector

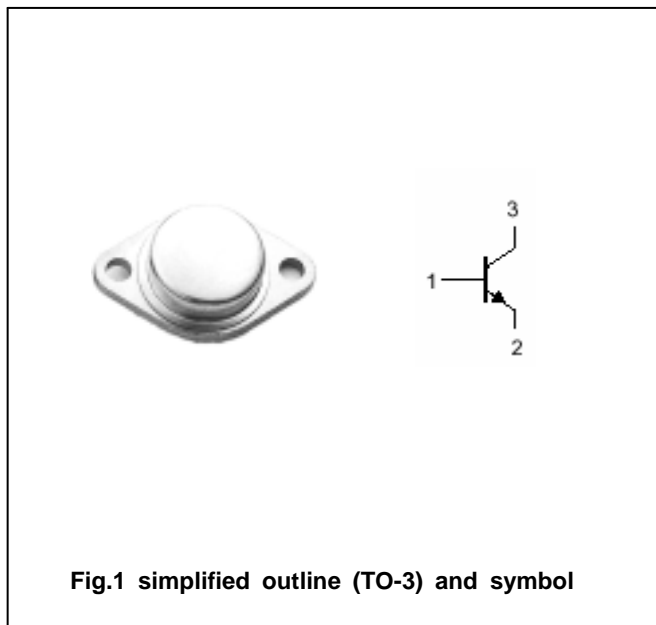

Fig.1 simplified outline (TO-3) and symbol

Absolute maximum ratings (Tc=25)

SYMBOL	PARAMETER	CONDITIONS	VALUE	UNIT
V _{CBO}	Collector-base voltage	BU326	800	V
		BU326A	900	
V _{CEO}	Collector-emitter voltage	BU326	375	V
		BU326A	400	
V _{EBO}	Emitter-base voltage	Open collector	10	V
I _C	Collector current		6	A
I _{CM}	Collector current-peak		8	A
I _B	Base current		3	A
P _T	Total power dissipation	T _C =25	75	W
T _j	Junction temperature		-65~200	
T _{stg}	Storage temperature		-65~200	

THERMAL CHARACTERISTICS

SYMBOL	PARAMETER	MAX	UNIT
R _{th j-c}	Thermal resistance junction to case	2.33	/W

Silicon NPN Power Transistors

BU326 BU326A

CHARACTERISTICS

T_j=25 unless otherwise specified

SYMBOL	PARAMETER	CONDITIONS	MIN	TYP.	MAX	UNIT
V _{CEO(SUS)}	Collector-emitter sustaining voltage	BU326	I _C =0.1A; I _B =0			V
		BU326A				
V _{CEsat-1}	Collector-emitter saturation voltage	I _C =2.5 A; I _B =0.5A			1.5	V
V _{CEsat-2}	Collector-emitter saturation voltage	I _C =4A; I _B =1.25 A			3.0	V
V _{BEsat-1}	Base-emitter saturation voltage	I _C =2.5 A; I _B =0.5A			1.4	V
V _{BEsat-2}	Base-emitter saturation voltage	I _C =4A; I _B =1.25 A			1.6	V
I _{CES}	Collector cut-off current	BU326			1	mA
		BU326A				
I _{EBO}	Emitter cut-off current	V _{EB} =10V; I _C =0			10	mA
h _{FE}	DC current gain	I _C =1A; V _{CE} =5V		25		
f _T	Transition frequency	I _C =0.2A; V _{CE} =10V; f=1MHz	4.0			MHz

Switching times

t _{on}	Turn-on time	I _C =2.5A ; I _{B1} =0.5A; I _{B2} =-1A V _{CC} =250V ;			0.5	μs
t _s	Storage time				3.5	μs
t _f	Fall time				0.5	μs

PACKAGE OUTLINE

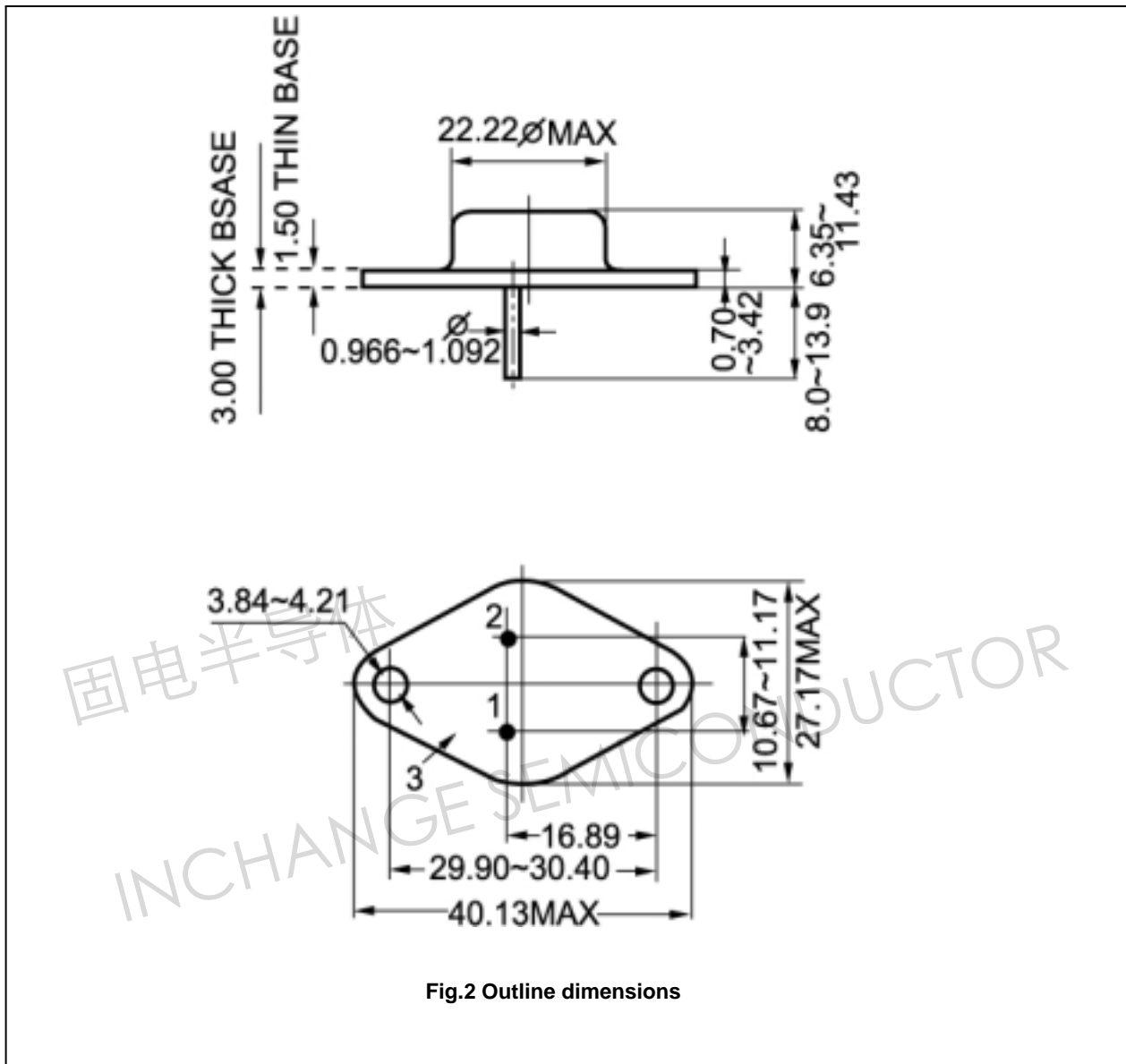

Fig.2 Outline dimensions