

Silicon NPN Power Transistors

2SC1567 2SC1567A

DESCRIPTION

- With TO-126 package
- Complement to type 2SA794/794A
- High collector to emitter voltage V_{CEO}

APPLICATIONS

- For low-frequency high power driver applications
- Optimum for the driver stage of low-frequency and 40 W to 100 W output amplifier

PINNING

PIN	DESCRIPTION
1	Emitter
2	Collector;connected to mounting base
3	Base

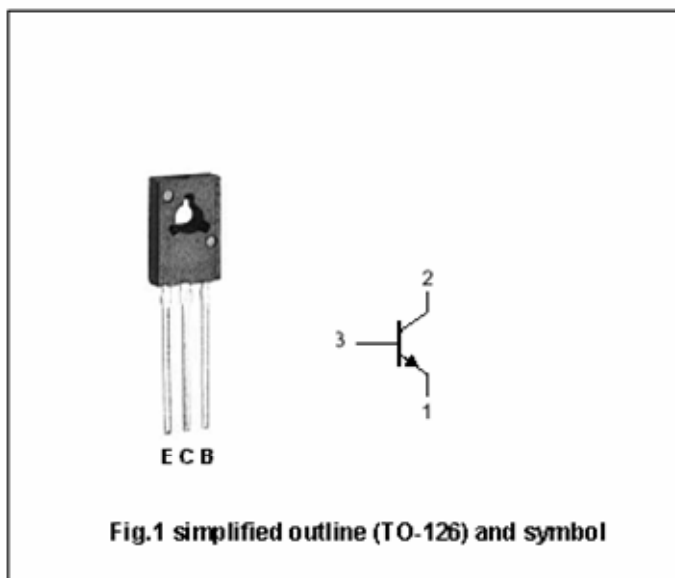

Absolute maximum ratings($T_a=25$)

SYMBOL	PARAMETER	CONDITIONS	VALUE	UNIT
V_{CBO}	Collector-base voltage	2SC1567	100	V
		2SC1567A	120	
V_{CEO}	Collector- emitter voltage	2SC1567	100	V
		2SC1567A	120	
V_{EBO}	Emitter-base voltage	Open collector	5	V
I_C	Collector current		0.5	A
I_{CM}	Collector current-peak		1	A
P_D	Total power dissipation	$T_C=25$	1.2	W
T_j	Junction temperature		150	
T_{stg}	Storage temperature		-55 ~ +150	

Silicon NPN Power Transistors

2SC1567 2SC1567A

CHARACTERISTICS

T_j=25 unless otherwise specified

SYMBOL	PARAMETER		CONDITIONS	MIN	TYP.	MAX	UNIT
V _{(BR)CEO}	Collector-emitter breakdown voltage	2SC1567	I _C =0.1mA ; I _B =0	100			V
		2SC1567A		120			
V _{(BR)EBO}	Emitter-base breakdown voltage		I _E =1 μ A ; I _C =0	5			V
V _{CEsat}	Collector-emitter saturation voltage		I _C =0.5A ; I _B =50m A		0.2	0.4	V
V _{BEsat}	Base-emitter saturation voltage		I _C =0.5A ; I _B =50m A		0.85	1.2	V
h _{FE-1}	DC current gain		I _C =150mA ; V _{CE} =10V	65		330	
h _{FE-2}	DC current gain		I _C =0.5A ; V _{CE} =5V	50			
C _{OB}	Output capacitance		I _E =0 ; V _{CB} =10V;f=1MHz		11		pF
f _T	Transition frequency		I _C =50mA ; V _{CE} =10V,f=200MHz		120		MHz

◆ h_{FE-1} Classifications

R	S
130-220	185-330

Silicon NPN Power Transistors

2SC1567 2SC1567A

PACKAGE OUTLINE

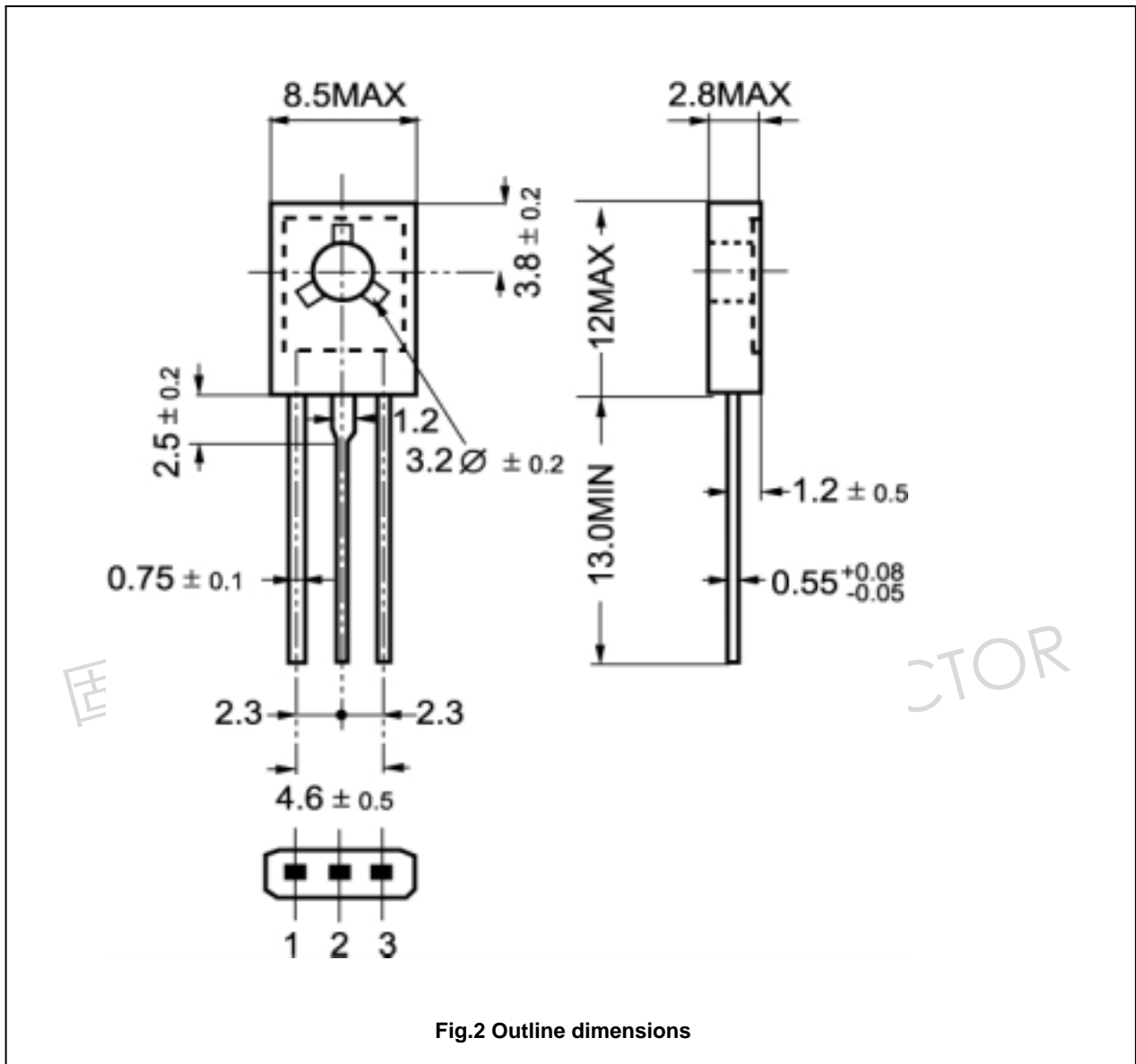

Fig.2 Outline dimensions