



STK4121V

AF Power Amplifier (Split Power Supply) (15 W + 15 W min, THD = 0.08 %)

Features

- Built-in muting circuit cuts off various kinds of pop noises.
- Current mirror circuit provides low distortion (THD = 0.08%).
- Pin compatible with the STK4102II series, forming a series of products with output powers from 15 W/ch to 120 W/ch.

Specified Transformer Power Supply (RP-22 equivalent)

Package Dimensions

unit: mm

4040

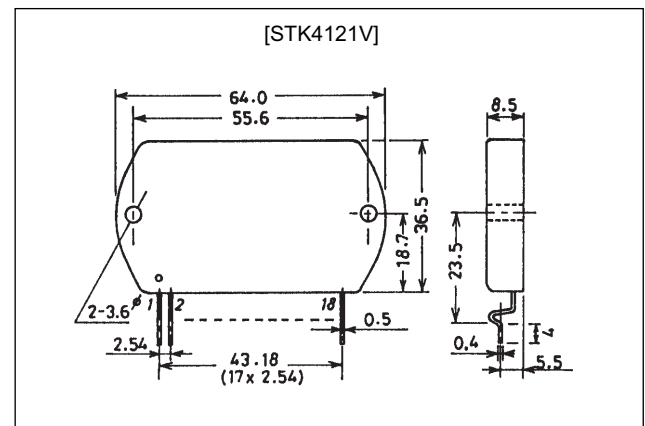

Specifications

Maximum Ratings at Ta = 25°C

Parameter	Symbol	Conditions	Ratings	Unit
Maximum supply voltage	V_{CC} max		± 32	V
Thermal resistance	θ_{j-c}		2.6	°C/W
Junction temperature	T_j max		150	°C
Operating substrate temperature	T_c		125	°C
Storage temperature	T_{stg}		-30 to +125	°C
Available time for load short circuit	t_s	$V_{CC} = \pm 21.5$ V, $R_L = 8$ Ω , $f = 50$ Hz, $P_O = 15$ W	2	s

Recommended Operating Conditions at Ta = 25°C

Parameter	Symbol	Conditions	Ratings	Unit
Recommended supply voltage	V_{CC}		± 21.5	V
Load resistance	R_L		8	Ω

STK4121V

Operating Characteristics

at $T_a = 25^\circ\text{C}$, $V_{CC} = \pm 21.5\text{ V}$, $R_L = 8\ \Omega$, $R_g = 600\ \Omega$, $V_G = 40\ \text{dB}$, R_L : non-inductive load

Parameter	Symbol	Conditions	Ratings			Unit
			min	typ	max	
Quiescent current	I_{CCO}	$V_{CC} = \pm 26\text{ V}$	20	40	100	mA
Output power	$P_o(1)$	THD = 0.08%, $f = 20\text{ Hz to } 20\text{ kHz}$	15			W
	$P_o(2)$	$V_{CC} = \pm 18\text{ V}$, THD = 0.2%, $R_L = 4\ \Omega$, $f = 1\text{ kHz}$	15			W
Total harmonic distortion	THD	$P_o = 1.0\text{ W}$, $f = 1\text{ kHz}$			0.08	%
Frequency response	f_L, f_H	$P_o = 1.0\text{ W}$, $+0_{-3}\text{ dB}$		20 to 50 k		Hz
Input impedance	r_i	$P_o = 1.0\text{ W}$, $f = 1\text{ kHz}$		55		k Ω
Output noise voltage	V_{NO}	$V_{CC} = \pm 26\text{ V}$, $R_g = 10\text{ k}\Omega$			1.2	mVrms
Neutral voltage	V_N	$V_{CC} = \pm 26\text{ V}$	-70	0	+70	mV
Muting voltage	V_M		-2	-5	-10	V

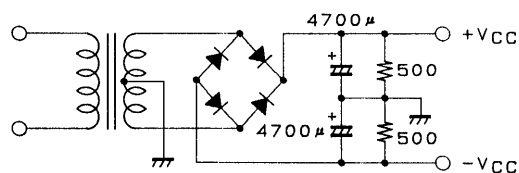

A01190

Unit (resistance: Ω , capacitance:F)

Notes

- Use a constant voltage power supply for the test power supply unless otherwise noted.
- Use the transformer power supply shown in the figure above when measuring the available time for load short circuit and the output noise voltage.
- The output noise voltage is the peak value measured with an averaging rms scale volt meter (VTVM). A 50 Hz AC stabilized power supply should be used to eliminate the effects of AC primary line flicker noise when an AC power supply is used.

Equivalent Circuit

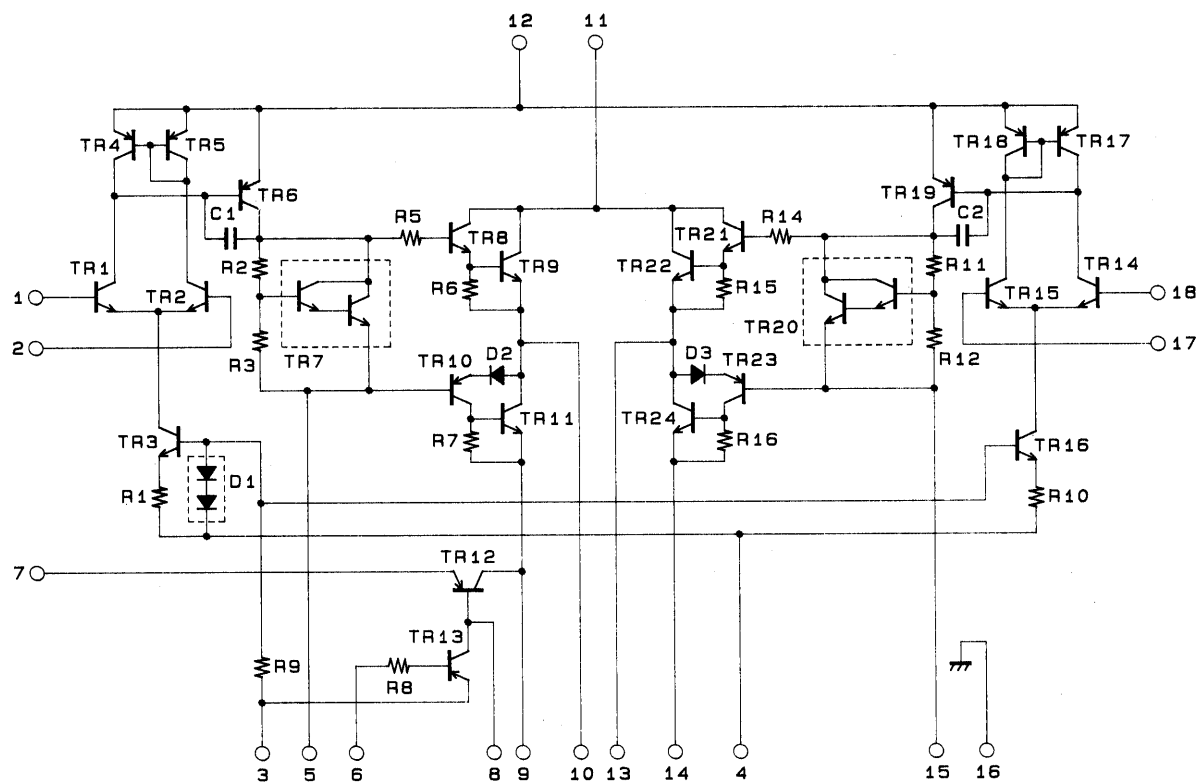

A01191

