

isc Silicon NPN Darlington Power Transistor

BDX53F

DESCRIPTION

- Collector Current $-I_C = 8A$
- High DC Current Gain-
: $h_{FE} = 500(\text{Min}) @ I_C = 2A$
- Complement to Type BDX54F

APPLICATIONS

- Designed for use in power linear and switching applications.

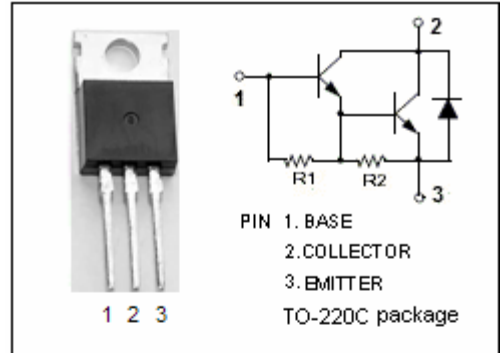

ABSOLUTE MAXIMUM RATINGS($T_a = 25^\circ\text{C}$)

SYMBOL	PARAMETER	VALUE	UNIT
V_{CER}	Collector-Emitter Voltage	160	V
V_{CEO}	Collector-Emitter Voltage	160	V
V_{EBO}	Emitter-Base Voltage	5	V
I_C	Collector Current-Continuous	8	A
I_{CM}	Collector Current-Peak	12	A
I_B	Base Current-Continuous	0.2	A
P_C	Collector Power Dissipation @ $T_C = 25^\circ\text{C}$	60	W
T_J	Junction Temperature	150	$^\circ\text{C}$
T_{stg}	Storage Temperature Range	-65~150	$^\circ\text{C}$

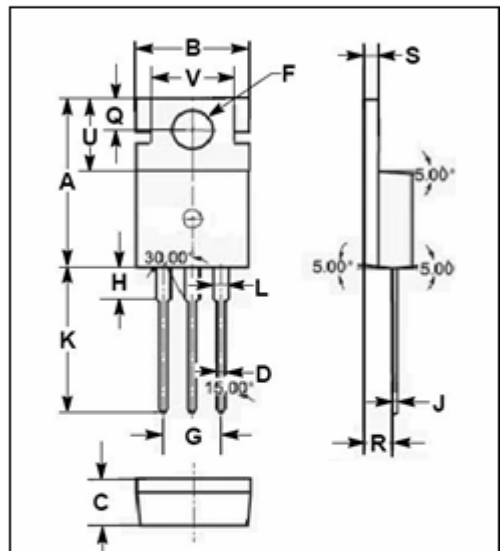

DIM	mm	
	MIN	MAX
A	15.70	15.90
B	9.90	10.10
C	4.20	4.40
D	0.70	0.90
F	3.40	3.60
G	4.98	5.18
H	2.70	2.90
J	0.44	0.46
K	13.20	13.40
L	1.10	1.30
Q	2.70	2.90
R	2.50	2.70
S	1.29	1.31
U	6.45	6.65
V	8.66	8.86

THERMAL CHARACTERISTICS

SYMBOL	PARAMETER	MAX	UNIT
$R_{th\ j-c}$	Thermal Resistance, Junction to Case	2.08	$^\circ\text{C/W}$
$R_{th\ j-a}$	Thermal Resistance, Junction to Ambient	70	$^\circ\text{C/W}$

isc Silicon NPN Darlington Power Transistor**BDX53F****ELECTRICAL CHARACTERISTICS** $T_C=25^\circ\text{C}$ unless otherwise specified

SYMBOL	PARAMETER	CONDITIONS	MIN	TYP.	MAX	UNIT
$V_{CEO(SUS)}$	Collector-Emitter Sustaining Voltage	$I_C= 50\text{mA}; I_B= 0$	160			V
$V_{CE(sat)}$	Collector-Emitter Saturation Voltage	$I_C= 2\text{A}; I_B= 10\text{mA}$			2.0	V
$V_{BE(sat)}$	Base-Emitter Saturation Voltage	$I_C= 2\text{A}; I_B= 10\text{mA}$			2.5	V
V_{ECF}	C-E Diode Forward Voltage	$I_F= 2\text{A}$			2.5	V
I_{CEO}	Collector Cutoff Current	$V_{CE}= 80\text{V}; I_B= 0$			0.5	mA
I_{CBO}	Collector Cutoff Current	$V_{CB}= 160\text{V}; I_E= 0$			0.2	mA
I_{EBO}	Emitter Cutoff Current	$V_{EB}= 5\text{V}; I_C= 0$			5	mA
h_{FE-1}	DC Current Gain	$I_C= 2\text{A}; V_{CE}= 5\text{V}$	500			
h_{FE-2}	DC Current Gain	$I_C= 3\text{A}; V_{CE}= 5\text{V}$	150			