

9097247 TOSHIBA. ELECTRONIC

02E 17137 D

TA7335P TA7335F

T-77-05-05

FM FRONT END IC

The TA7335P is a front end IC suitable for Portable Radio and Radio Cassette applications. This IC contains RF amplifier, MIX, local oscillator and varicap for AFC. This IC simplify the design of front end circuit.

- . Operating Supply Voltage
 - : $V_{CC}=2\sim 5V$TA7335F
 - $V_{CC}=2\sim 6V$TA7335P, TA7335P-LB
- . Local OSC Stop Voltage: $V_{CC}=1.5V$ (Typ.)
- . Varicap for AFC
- . Japan/U Band Available
- . The Item is Different Each Outlines
 - : TA7335P : Single in Line Package....Outline 1
 - TA7335P-LB: Lead Forming.....Outline 2
 - TA7335F : Flat Package.....Outline 3

MAXIMUM RATINGS ($T_a=25^{\circ}C$)

CHARACTERISTIC		SYMBOL	RATING	UNIT
Supply Voltage	TA7335P TA7335P-LB	V_{CC}	8	V
	TA7335F		6	
Power Dissipation (Note)	TA7335P TA7335P-LB	P_D	500	mW
	TA7335F		300	
Operating Temperature		T_{opr}	$-25\sim 75$	$^{\circ}C$
Storage Temperature		T_{stg}	$-55\sim 150$	$^{\circ}C$

Note : TA7335P, TA7335P-LB : Derated above $T_a=25^{\circ}C$ in the proportion of $5.6mW/^{\circ}C$.

TA7335F : Derated above $T_a=25^{\circ}C$ in the proportion of $2.8mW/^{\circ}C$.

Unit in mm

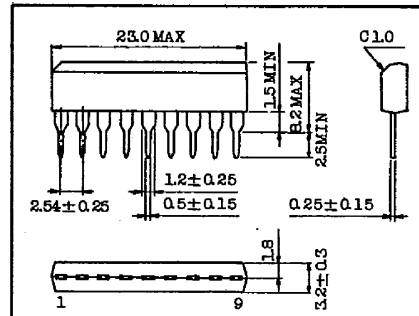

JEDEC —
TOSHIBA S9A-P OUTLINE(1)

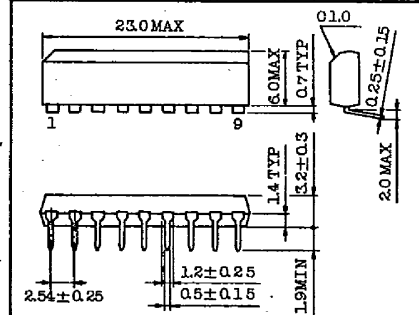

JEDEC —
TOSHIBA S9B-P OUTLINE(2)

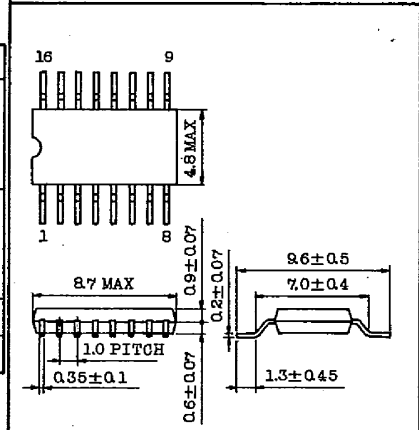

JEDEC —
TOSHIBA F16GA1-P OUTLINE(3)

9097247 TOSHIBA. ELECTRONIC

02E 17138 D

TA7335P
TA7335F

T-77-05-05

ELECTRICAL CHARACTERISTICS

(Unless otherwise specified $V_{CC}=4V$, $T_a=25^{\circ}C$)

CHARACTERISTIC	SYMBOL	TEST CIR-CUIT	TEST CONDITION	MIN.	TYP.	MAX.	UNIT	
Supply Current	I_{CC}	1	$V_{IN}=0$	-	2.5	4	mA	
Local OSC Voltage	V_{OSC}	1	$SW_1=A$, $f_{OSC}=60MHz$	40	75	200	mV _{rms}	
Conversion Gain	G_C	2	$f=83MHz$	-	20	-	dB	
Recovered Output Voltage	V_{OD}	2	$f=83MHz$, $4F=\pm 22.5kHz$ dev. $V_{IN}=12dB\mu V$	40	60	-	mV _{rms}	
Capacitance of AFC Diode	C_{AFC}	3	$V_{AFC}=1V$	-	3.8	-	pF	
Q of AFC Diode	Q	3	$V_{AFC}=1V$	-	100	-	-	
Capacitance V_{AFC} Dependence	K	3	$K = \frac{C(V_{AFC}=1V) - C(V_{AFC}=3V)}{C(V_{AFC}=3V)}$	-	0.23	-	-	
3 Pin Impedance	Parallel Output Resistance	r_{op3}	$f=83MHz$	-	24	-	k Ω	
	Parallel Output Capacitance	c_{op3}		-	3	-	pF	
4 Pin Impedance	Parallel Input Resistance	r_{ip4}		-	20	-	k Ω	
	Parallel Input Capacitance	c_{ip4}		-	3.2	-	pF	
6 Pin Impedance	Parallel Output Resistance	r_{op6}		$f=10.7MHz$	-	44	-	k Ω
	Parallel Output Capacitance	c_{op6}			-	3.7	-	pF
Local OSC Stop Voltage	V_{stp}	1	$SW_1=A$, $f_{OSC}=60MHz$	-	1.5	-	V	

AUDIO LINEAR IC

TA7335P
TA7335F

T-77-05-05

EQUIVALENT CIRCUIT AND TEST CIRCUIT (1)

TA7335P, TA7335P-LB

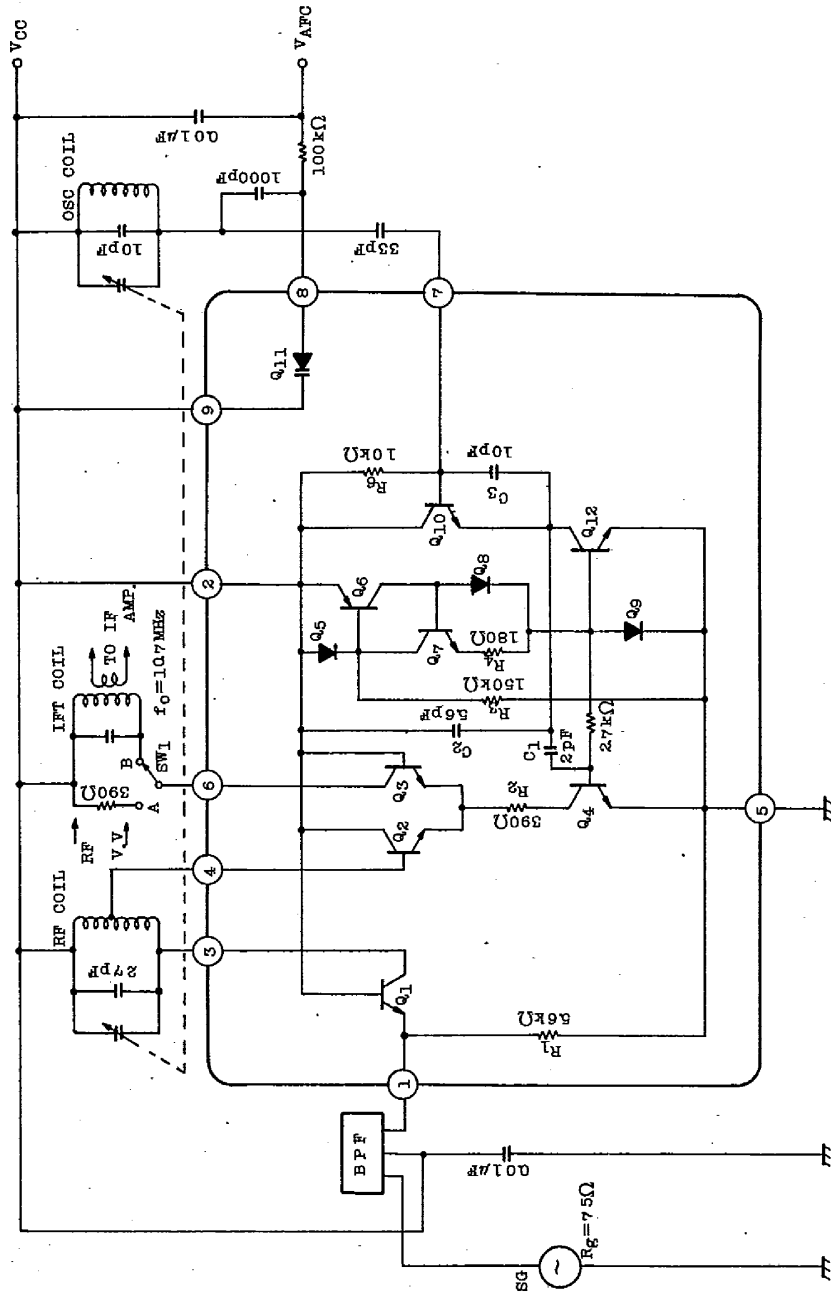

TA7335P TA7335F

T-77-05-05

TA7335F

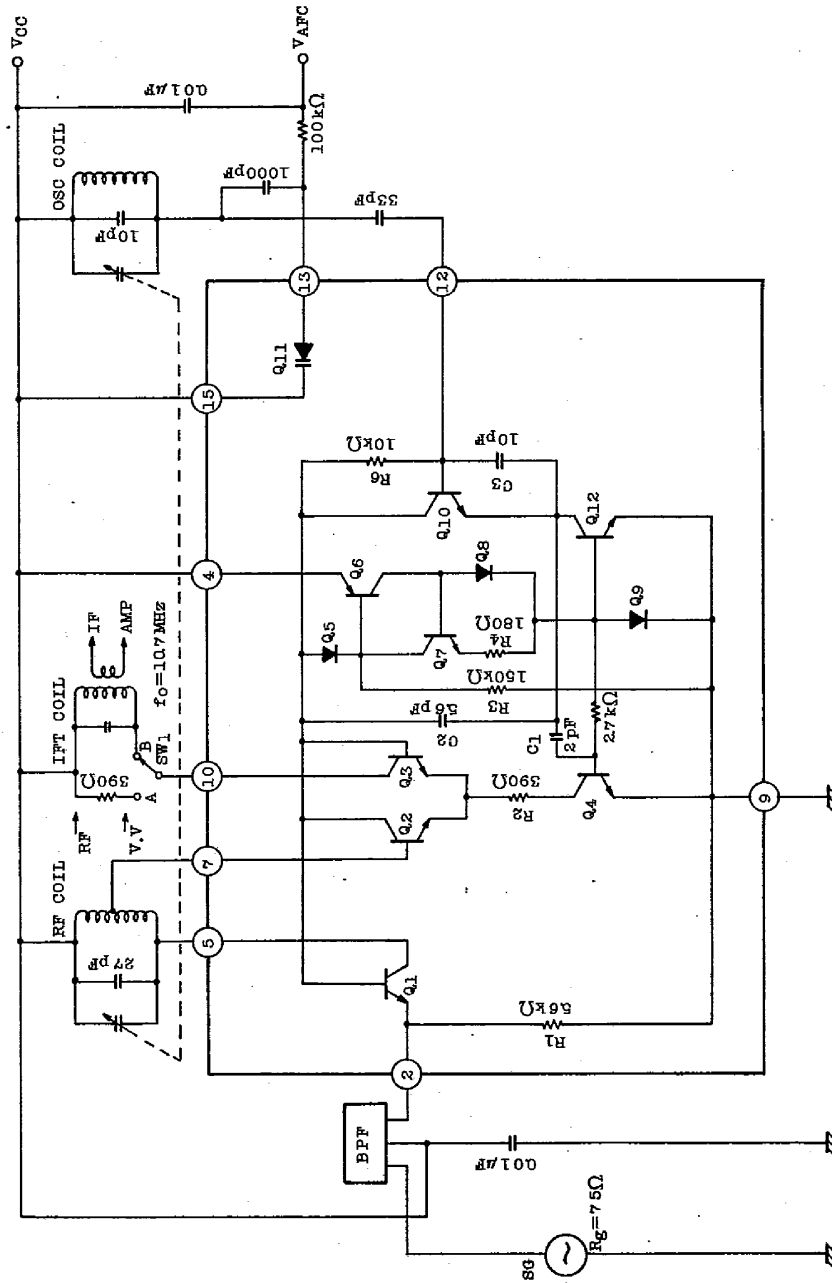

AUDIO LINEAR IC

9097247 TOSHIBA. ELECTRONIC

02E 17143 D

TA7335P
TA7335F

T-77-05-05

COIL DATA (TEST CIRCUIT 1,2, APPLICATION CIRCUIT)

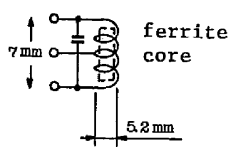
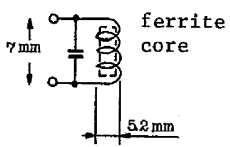
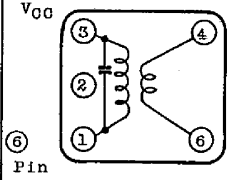
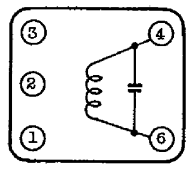
	f_0	Q_0	TURNS	CAPACITANCE	
RF Coil	83MHz	-	0.7mm ϕ 2 $\frac{1}{2}$ T Center Tap (JAPAN Band)	27pF	
OSC Coil	72.5MHz	-	0.7mm ϕ 3 $\frac{1}{2}$ T (JAPAN Band)	10pF	
IFT	10.7MHz	115	① - ③ 12T ④ - ⑥ 1T WIRE 0.12mm ϕ UEW SUMIDA ELECTRIC Co., LTD. S193-001 or (5764) or Equivalent	75pF	
Quad Coil	10.7MHz	150	④ - ⑥ 14T WIRE 0.12mm ϕ UEW SUMIDA ELECTRIC Co., LTD. 44M-933A or Equivalent	47pF	

Band Pass Filter (B.P.F.)

SOSHIN ELECTRIC Co., LTD. PFJB2 or Equivalent

TOSHIBA

TA7335P
TA7335F

T-77-05-05

TEST CIRCUIT 3

INPUT, OUTPUT IMPEDANCE, K

(1) r_{op3} , c_{op3}

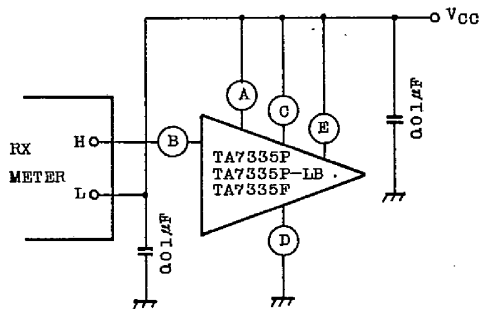

(2) r_{ip4} , c_{ip4}

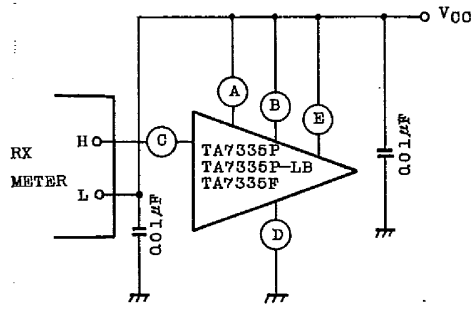

(3) r_{op6} , c_{op6}

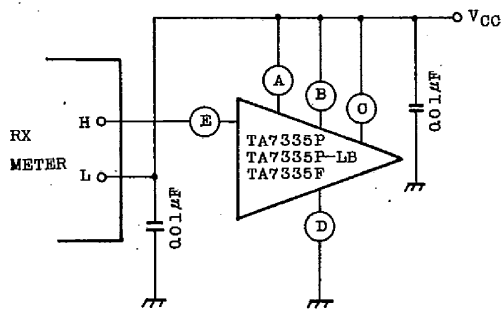

(4) C_{AFC} , K

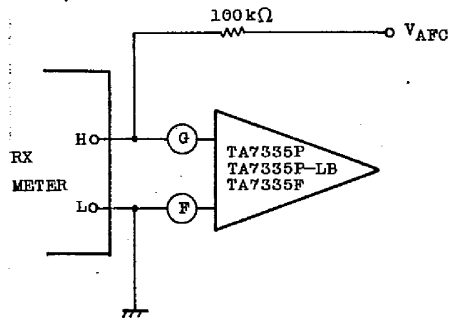

K (Capacitance V_{AFC} dependence) is defined by following equation

$$K = \frac{C(V_{AFC}=1V) - C(V_{AFC}=3V)}{C(V_{AFC}=3V)}$$

CONTRASTIVE A TABLE

ITEM \ PIN No.	A	B	C	D	E	F	G
TA7335P/P-LB	2	3	4	5	6	8	9
TA7335F	4	5	7	9	10	13	15

AUDIO LINEAR IC

9097247 TOSHIBA, ELECTRONIC

02E 17145 D

TA7335P
TA7335F

T-77-05-05

APPLICATION PRECAUTION

- (1) A core of local oscillation coil must be ferrite. If you use aluminium or brass core in stead of ferrite core, Q_0 becomes so small that there is a case of oscillation stop at low frequency.

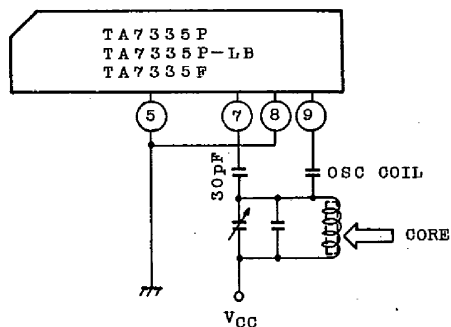

- (2) A capacitance between oscillation coil and ⑦ pin of IC is recommended to be more than 30pF. When this capacitance is so small, oscillation level at low frequency is small.

9097247 TOSHIBA. ELECTRONIC

02E 17146 D

TA7335P
TA7335F

T-77-05-05

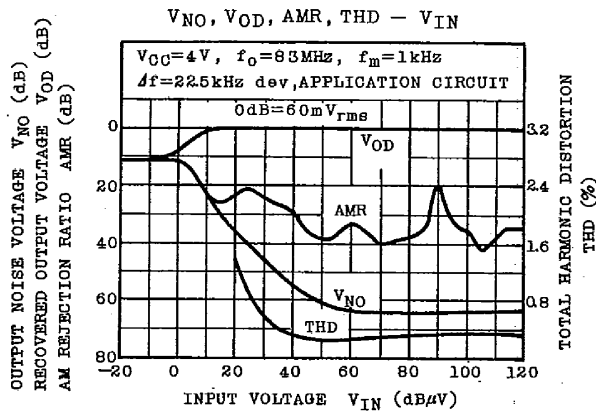
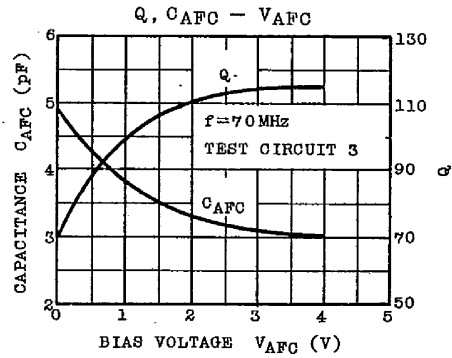
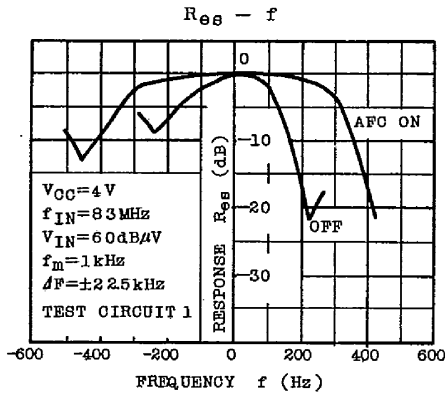
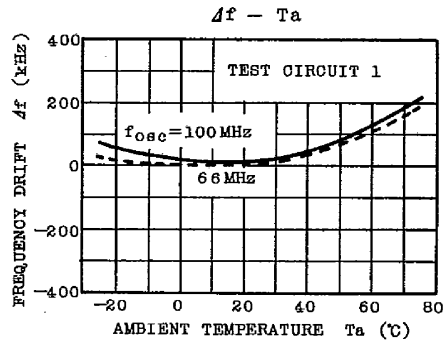
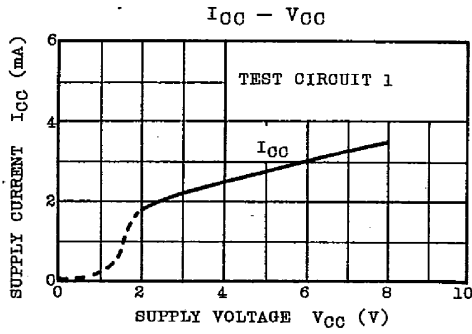

AUDIO LINEAR IC

TA7335P
TA7335F

T-77-05-05

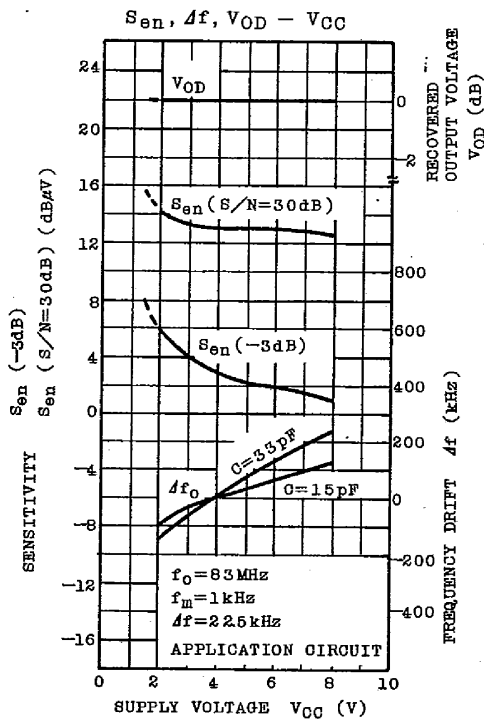
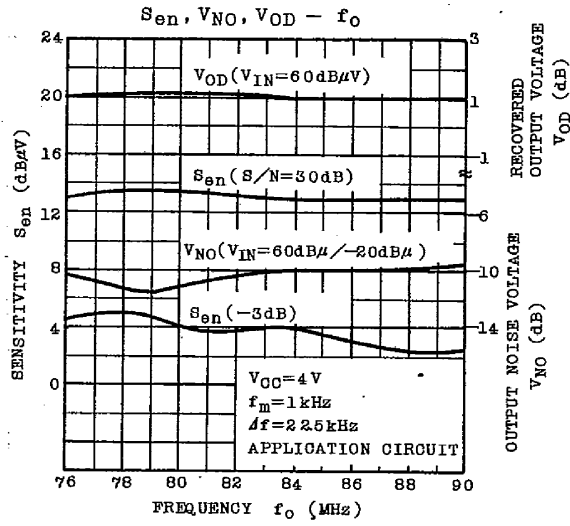

TA7335P
TA7335F

T-77-05-05

APPLICATION CIRCUIT

TA7335F

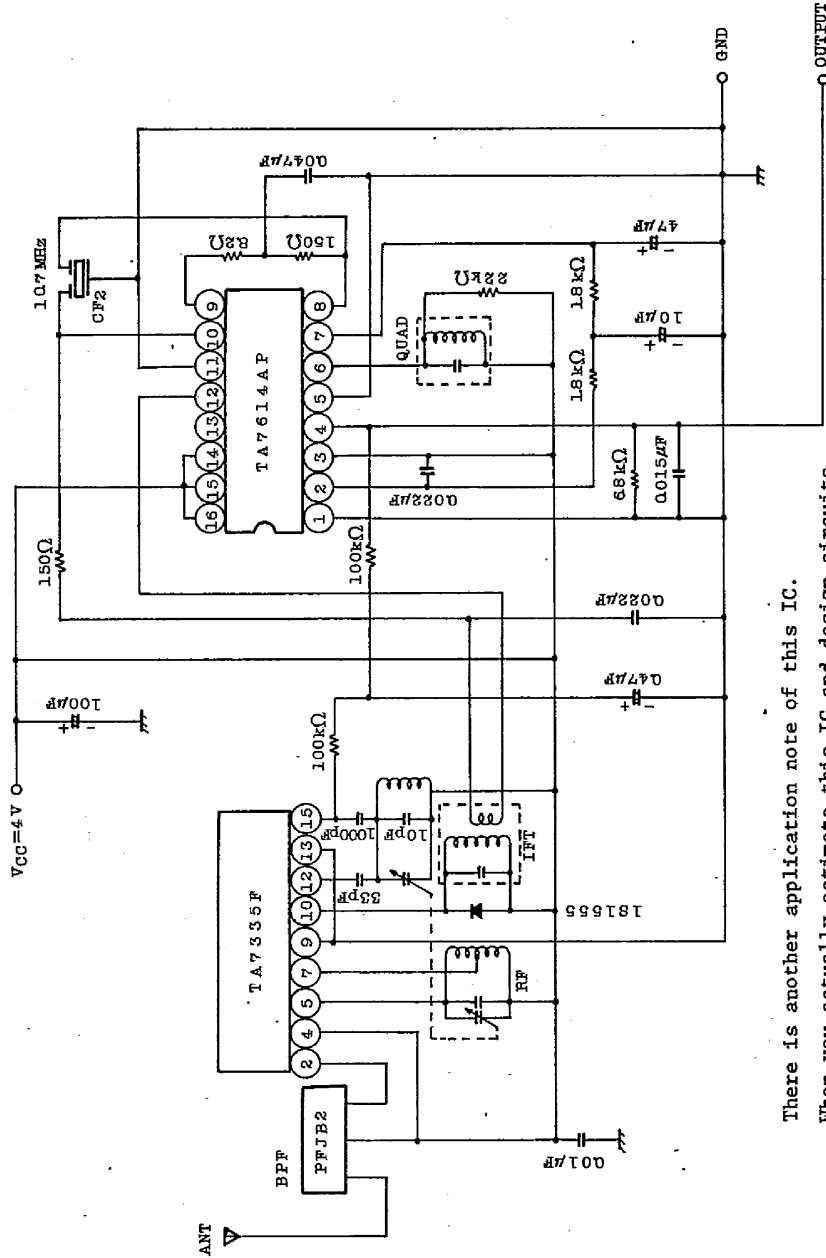

There is another application note of this IC.
When you actually estimate this IC and design circuits,
please request us it.