

Silicon NPN Power Transistors

BUT11AX

DESCRIPTION

- With TO-220F package
- High voltage ,high speed

APPLICATIONS

- Converters
- Inverters
- Switching regulators
- Motor control systems

PINNING

PIN	DESCRIPTION
1	Base
2	Collector;connected to mounting base
3	Emitter

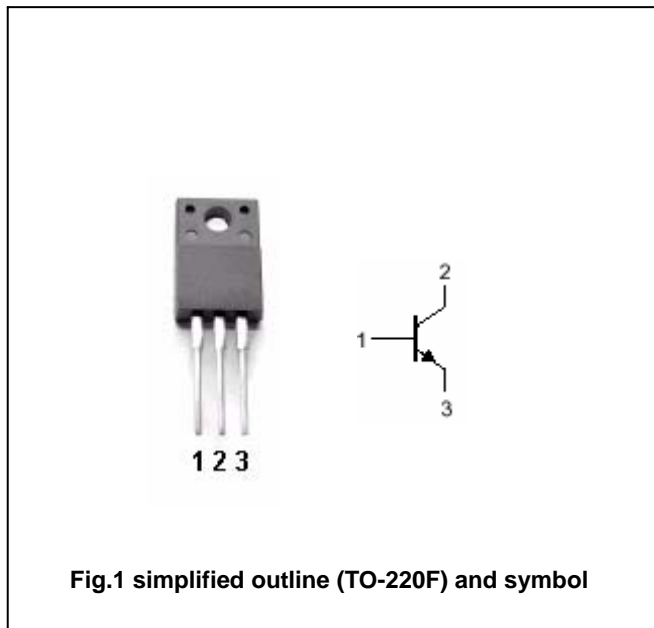

Absolute maximum ratings (Tc=25 )

SYMBOL	PARAMETER	CONDITIONS	VALUE	UNIT
V <sub>CBO</sub>	Collector-base voltage	Open emitter	1000	V
V <sub>CEO</sub>	Collector-emitter voltage	Open base	450	V
V <sub>EBO</sub>	Emitter-base voltage	Open collector	9	V
I <sub>C</sub>	Collector current		5	A
I <sub>CM</sub>	Collector current-peak		10	A
I <sub>B</sub>	Base current		2	A
I <sub>BM</sub>	Base current-peak		4	A
P <sub>tot</sub>	Total power dissipation	T <sub>C</sub> =25	32	W
T <sub>j</sub>	Junction temperature		150	
T <sub>stg</sub>	Storage temperature		-65~150	

THERMAL CHARACTERISTICS

SYMBOL	PARAMETER	VALUE	UNIT
R <sub>th j-c</sub>	Thermal resistance from junction to case	3.95	K/W

## Silicon NPN Power Transistors

## BUT11AX

## CHARACTERISTICS

T<sub>j</sub>=25 unless otherwise specified

SYMBOL	PARAMETER	CONDITIONS	MIN	TYP.	MAX	UNIT
V <sub>CEO(SUS)</sub>	Collector-emitter sustaining voltage	I <sub>C</sub> =0.1A; I <sub>B</sub> =0; L=25mH	450			V
V <sub>CEsat</sub>	Collector-emitter saturation voltage	I <sub>C</sub> =2.5A; I <sub>B</sub> =0.5A			1.5	V
V <sub>BEsat</sub>	Base-emitter saturation voltage	I <sub>C</sub> =2.5A; I <sub>B</sub> =0.5A			1.3	V
I <sub>CES</sub>	Collector cut-off current	V <sub>CE</sub> =Rated V <sub>CEs</sub> ; V <sub>BE</sub> =0 T <sub>j</sub> =125			1.0 2.0	mA
I <sub>EBO</sub>	Emitter cut-off current	V <sub>EB</sub> =9V; I <sub>C</sub> =0			10	mA
h <sub>FE-1</sub>	DC current gain	I <sub>C</sub> =5mA; V <sub>CE</sub> =5V	10		35	
h <sub>FE-2</sub>	DC current gain	I <sub>C</sub> =0.5A; V <sub>CE</sub> =5V	10		35	
Switching times resistive load						
t <sub>on</sub>	Turn-on time	I <sub>C</sub> =2.5A; I <sub>B1</sub> =- I <sub>B2</sub> =0.5A		0.6		μs
t <sub>s</sub>	Storage time			3.5		μs
t <sub>f</sub>	Fall time			0.6		μs

Silicon NPN Power Transistors

BUT11AX

PACKAGE OUTLINE

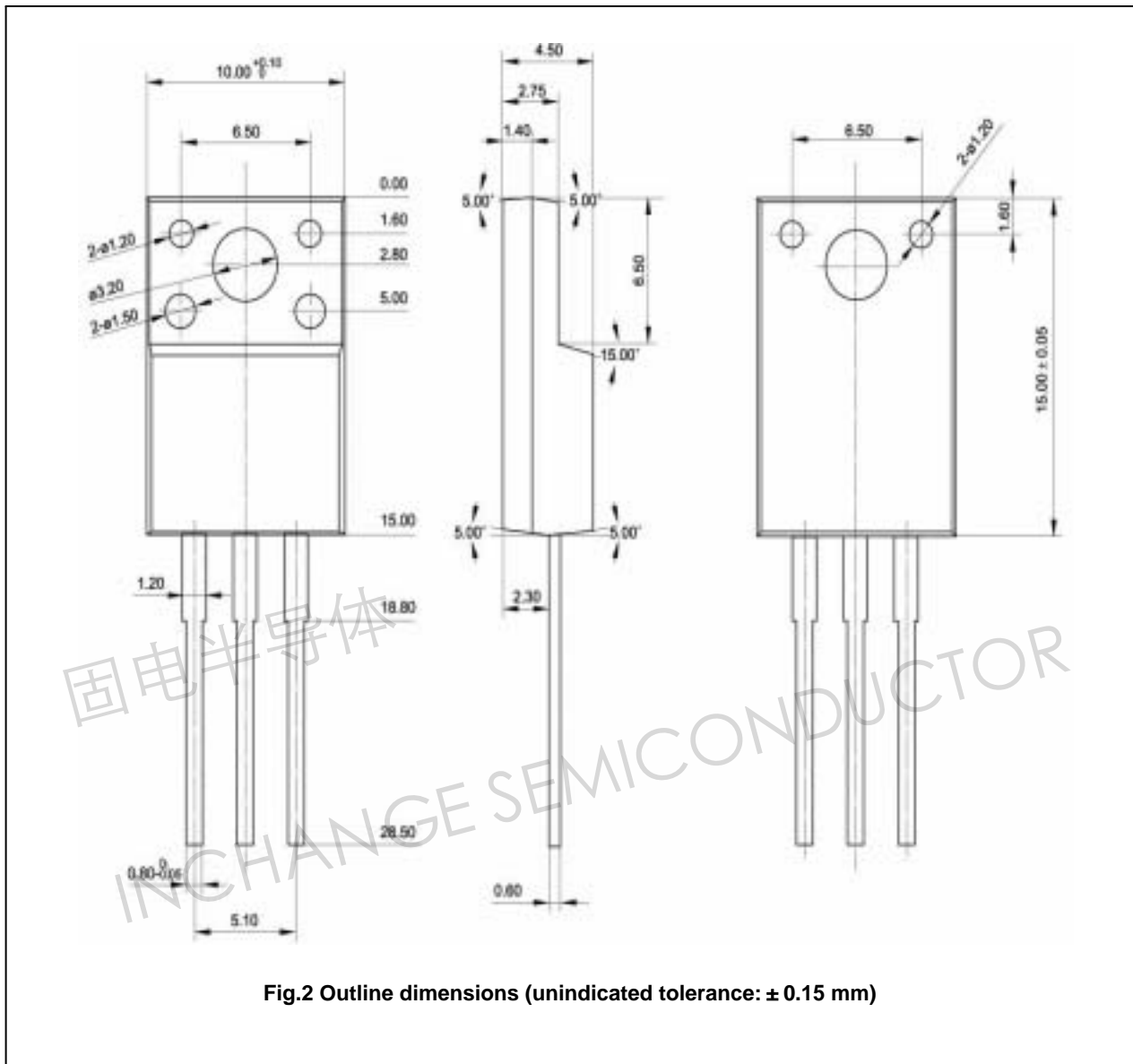

Fig.2 Outline dimensions (unindicated tolerance: ± 0.15 mm)