

# Speech network

## BA6566 / BA6566F / BA6566FP

The BA6566, BA6566F, and BA6566FP are speech network ICs which possess the basic functions required for handset communications. In addition to amplifying signals from a transmitter and sending them to a telephone line, they amplify only reception signals from a telephone line and drive the receiver. They also compensate for fluctuation in the volume at which signals are transmitted and received, caused by the length of the telephone line (AGC).

●Applications

Telephones and telephone equipment

●Features

- 1) Can accommodate both dynamic and piezoelectric receivers, simply by changing the circuit constant for a wide dynamic reception range.
- 2) Automatic gain control (AGC) is used, based on the transmission and reception telephone line current, for easier compliance with communications standards.
- 3) Erroneous operation caused by high-frequency electrical wave interference is minimized.
- 4) An HSOP package is used, eliminating the need for an attached transistor to dissipate heat. This means that a common circuit can be shared when a DIP package is used (BA6566FP).

●Block diagram

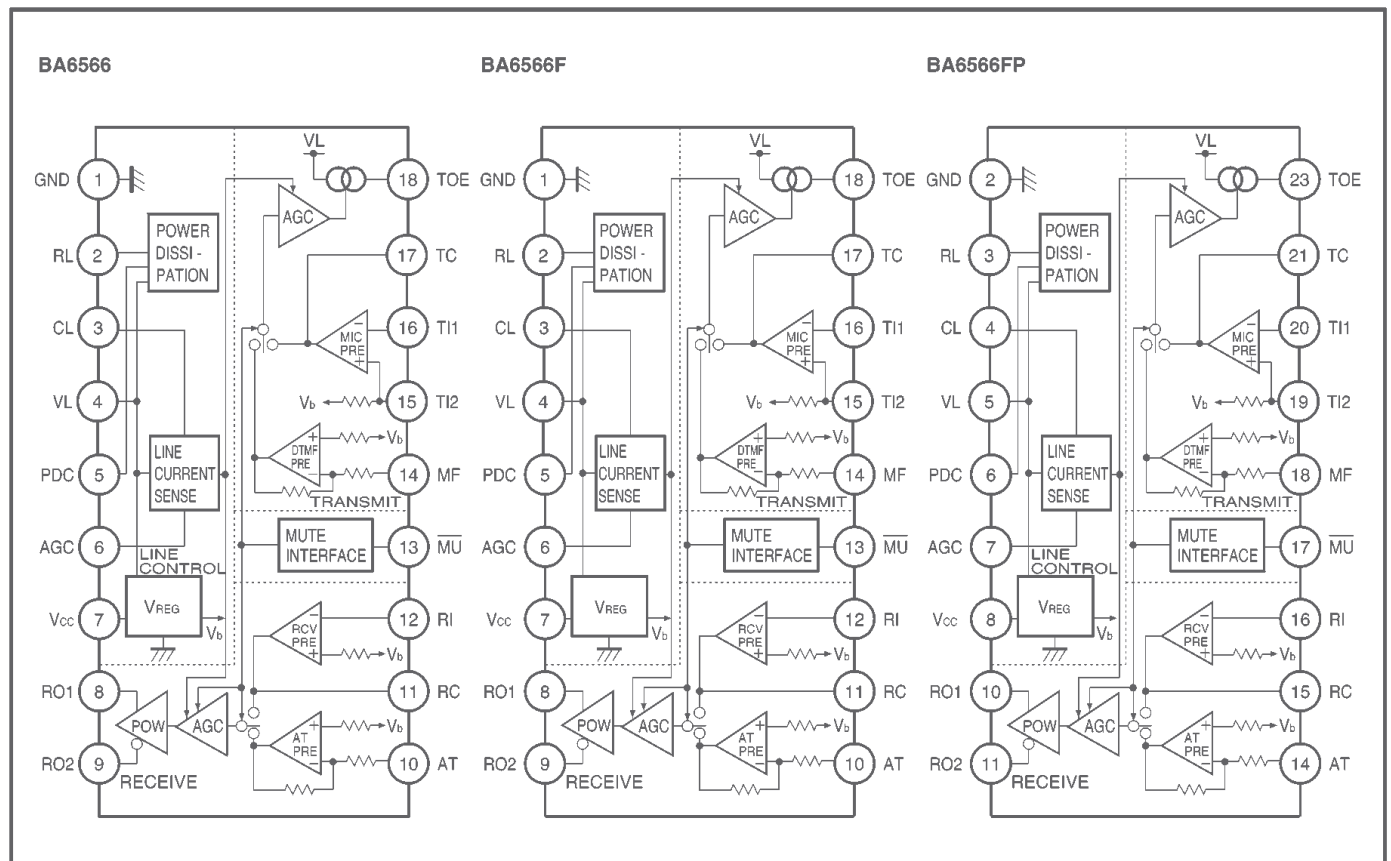

## ● Absolute maximum ratings (Ta=25°C)

Parameter	Symbol	Limits	Unit
Applied voltage	V <sub>L</sub>	16.5	V
Power dissipation	BA6566	1100* <sup>1</sup>	mW
	BA6566F	600* <sup>2</sup>	
	BA6566FP	1350* <sup>3</sup>	
Operating temperature	T <sub>opr</sub>	-35~+60	°C
Storage temperature	T <sub>stg</sub>	-55~+125	°C
Current dissipation	I <sub>L</sub>	125* <sup>4</sup>	mA

\*1 Reduced by 11 mW for each increase in Ta of 1°C over 25°C.

\*2 Reduced by 6 mW for each increase in Ta of 1°C over 25°C.

\*3 Reduced by 13.5 mW for each increase in Ta of 1°C over 25°C.

When mounted on 90 mm × 50 mm × 1.6 mm glass epoxy board, fins should be soldered to foil pattern.

\*4 With the BA6566, Reduced by 1 mA for each increase in Ta of 1°C over 50°C.

With the BA6566F, Reduced by 1.4 mA for each increase in Ta of 1°C over 50°C.

With the BA6566FP, Reduced by 1 mA for each increase in Ta of 1°C over 50°C.

●Electrical characteristics (Ta=25°C)

Parameter	Symbol	Min.	Typ.	Max.	Unit	Conditions				Measurement circuit
						I <sub>L</sub> (mA)	AGC	Mute	f=1kHz	
Line voltage (5)	V <sub>L</sub> (5)	—	2.0	—	V	5	—	—	—	Fig.2
Line voltage (20)	V <sub>L</sub> (20)	2.5	3.5	5.0	V	20	—	—	—	Fig.2
Line voltage (30)	V <sub>L</sub> (30)	3.0	4.0	5.4	V	30	—	—	—	Fig.2
Line voltage (90)	V <sub>L</sub> (90)	5.2	7.0	9.5	V	90	—	—	—	Fig.2
Mute input low level voltage	V <sub>IL</sub>	0.1	0.18	0.25	V	20~90	—	—	—	Fig.2
Mute input low level current	I <sub>IL</sub>	25	35	45	μA	20~90	—	—	—	Fig.2
Transmit gain 1 (20 - 90)	G <sub>T1</sub> (20 - 90)	37	41	44	dB	20~90	OFF	OFF	V <sub>IN</sub> =-50dBV	Fig.3
Transmit gain 1 (30 - 90)	G <sub>T1</sub> (30 - 90)	38	41	44	dB	30~90	OFF	OFF	V <sub>IN</sub> =-50dBV	Fig.3
Transmit gain 2 (20)	G <sub>T2</sub> (20)	38	41	45	dB	20	ON	OFF	V <sub>IN</sub> =-50dBV	Fig.3
Transmit gain 2 (30)	G <sub>T2</sub> (30)	38	41	44	dB	30	ON	OFF	V <sub>IN</sub> =-50dBV	Fig.3
Transmit gain 2 (90)	G <sub>T2</sub> (90)	34.5	37.5	40.5	dB	90	ON	OFF	V <sub>IN</sub> =-50dBV	Fig.3
Transmit distortion attenuation	D <sub>T</sub>	—	-46	-20	dB	20~90	—	OFF	V <sub>IN</sub> =-50dBV	Fig.3
Transmit noise level	N <sub>T</sub>	—	-68	-55	dBV	20~90	—	OFF	BPF=400Hz ~30kHz	Fig.3
Maximum transmit output level (20 - 90)	O <sub>T</sub> (20 - 90)	-2	3	—	dBV	20~90	—	OFF	Dist=-20dB	Fig.3
Maximum transmit output level (30 - 90)	O <sub>T</sub> (30 - 90)	0	3	—	dBV	30~90	—	OFF	Dist=-20dB	Fig.3
Receive gain 1 (20 - 90)	G <sub>R1</sub> (20 - 90)	-13	-10	-7	dB	20~90	OFF	OFF	S <sub>1</sub> =1 V <sub>IN</sub> =-20dBV	Fig.4
Receive gain 1 (20)	G <sub>R1</sub> (20)	-13	-10	-7	dB	20	ON	OFF	S <sub>1</sub> =1 V <sub>IN</sub> =-20dBV	Fig.4
Receive gain 1 (30)	G <sub>R1</sub> (30)	-13	-10	-7	dB	30	ON	OFF	S <sub>1</sub> =1 V <sub>IN</sub> =-20dBV	Fig.4
Receive gain 1 (90)	G <sub>R1</sub> (90)	-16.5	-13.5	-10.5	dB	90	ON	OFF	S <sub>1</sub> =1 V <sub>IN</sub> =-20dBV	Fig.4
Receive distortion attenuation 1	D <sub>R1</sub>	—	-46	-20	dB	20~90	—	OFF	S <sub>1</sub> =1 V <sub>IN</sub> =-20dBV	Fig.4
Receive noise level 1	N <sub>R1</sub>	—	-70	-60	dBV	20~90	—	OFF	BPF=400Hz ~30kHz	Fig.4
Maximum receive output level 1 (20 - 90)	O <sub>R1</sub> (20 - 90)	-15	-7	—	dBV	20~90	—	OFF	Dist=-20dB	Fig.4
Maximum receive output level 1 (30 - 90)	O <sub>R1</sub> (30 - 90)	-11	-7	—	dBV	30~90	—	OFF	Dist=-20dB	Fig.4
Receive gain 2 (20 - 90)	G <sub>R2</sub> (20 - 90)	5	8	11	dB	20~90	OFF	OFF	S <sub>1</sub> =2 V <sub>IN</sub> =-20dBV	Fig.4
Receive gain 2 (20)	G <sub>R2</sub> (20)	5	8	11	dB	20	ON	OFF	S <sub>1</sub> =2 V <sub>IN</sub> =-20dBV	Fig.4

Parameter	Symbol	Min.	Typ.	Max.	Unit	Conditions				Measurement circuit
						I <sub>L</sub> (mA)	AGC	Mute	f=1 kHz	
Receive gain 2 (30)	G <sub>R2</sub> (30)	5	8	11	dB	30	ON	OFF	S <sub>1</sub> =2 V <sub>IN</sub> =-20dBV	Fig.4
Receive gain 2 (90)	G <sub>R2</sub> (90)	1.5	4.5	7.5	dB	90	ON	OFF	S <sub>1</sub> =2 V <sub>IN</sub> =-20dBV	Fig.4
Receive distortion attenuation 2	D <sub>R2</sub>	—	-46	-20	dB	20~90	—	OFF	S <sub>1</sub> =2 V <sub>IN</sub> =-20dBV	Fig.4
Receive noise level (20 - 90)	N <sub>R2</sub> (20 - 90)	—	-66	-50	dBV	20~90	—	OFF	BPF=400Hz ~30kHz	Fig.4
Receive noise level 2 (30 - 90)	N <sub>R2</sub> (30 - 90)	—	-66	-55	dBV	30~90	—	OFF	BPF=400Hz ~30kHz	Fig.4
Maximum receive output level 2 (20 - 90)	O <sub>R2</sub> (20 - 90)	1	7	—	dBV	20~90	—	OFF	Dist=-20dB	Fig.4
Maximum receive output level 2 (30 - 90)	O <sub>R2</sub> (30 - 90)	3	7	—	dBV	30~90	—	OFF	Dist=-20dB	Fig.4
DTMF gain 1 (20 - 90)	G <sub>D1</sub> (20 - 90)	30.5	33.5	36.5	dB	20~90	OFF	ON	V <sub>IN</sub> =-40dBV	Fig.5
DTMF gain 2 (20)	G <sub>D1</sub> (20)	30	33	36	dB	20	ON	ON	V <sub>IN</sub> =-40dBV	Fig.5
DTMF gain 2 (30)	G <sub>D2</sub> (30)	30	33	36	dB	30	ON	ON	V <sub>IN</sub> =-40dBV	Fig.5
DTMF gain 2 (90)	G <sub>D2</sub> (90)	27	30	33	dB	90	ON	ON	V <sub>IN</sub> =-40dBV	Fig.5
DTMF distortion attenuation	D <sub>D</sub>	—	-41	-28	dB	20~90	—	ON	V <sub>IN</sub> =-40dBV	Fig.5
DTMF noise level (20 - 90)	N <sub>D</sub>	—	-64	-55	dBV	20~90	—	ON	BPF=400Hz ~30kHz	Fig.5
Maximum DTMF output level (20 - 90)	O <sub>D</sub> (20 - 90)	-4.5	-0.5	—	dBV	20~90	—	ON	Dist=-28dB	Fig.5
Maximum DTMF output level (30 - 90)	O <sub>D</sub> (30 - 90)	-3.5	-0.5	—	dBV	30~90	—	ON	Dist=-28dB	Fig.5
AT gain 1	G <sub>A1</sub>	23.5	26.5	29.5	dB	20~90	—	ON	S <sub>1</sub> =1 V <sub>IN</sub> =-40dBV	Fig.6
AT gain 2	G <sub>A2</sub>	26.5	29.5	32.5	dB	20~90	—	ON	S <sub>1</sub> =2 V <sub>IN</sub> =-40dBV	Fig.6
AC impedance	Z <sub>TEL</sub>	450	565	750	Ω	20~90	—	—	V <sub>IN</sub> =-20dBV	Fig.7
V <sub>CC</sub> pin voltage	V <sub>CCR</sub>	1.15	1.27	—	V	20	—	—	S <sub>3</sub> =ON	Fig.2

● Measurement circuits

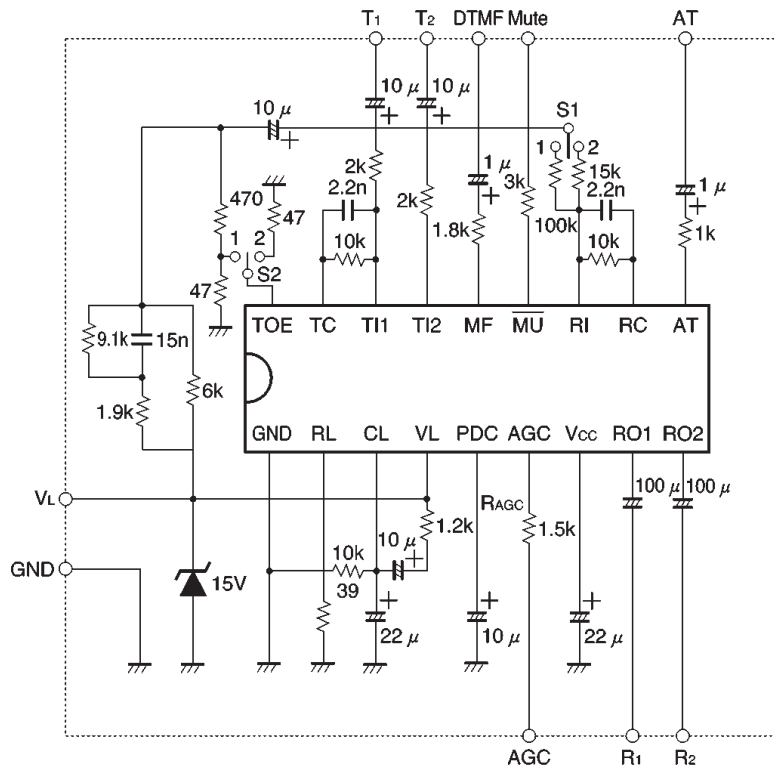

Fig. 1

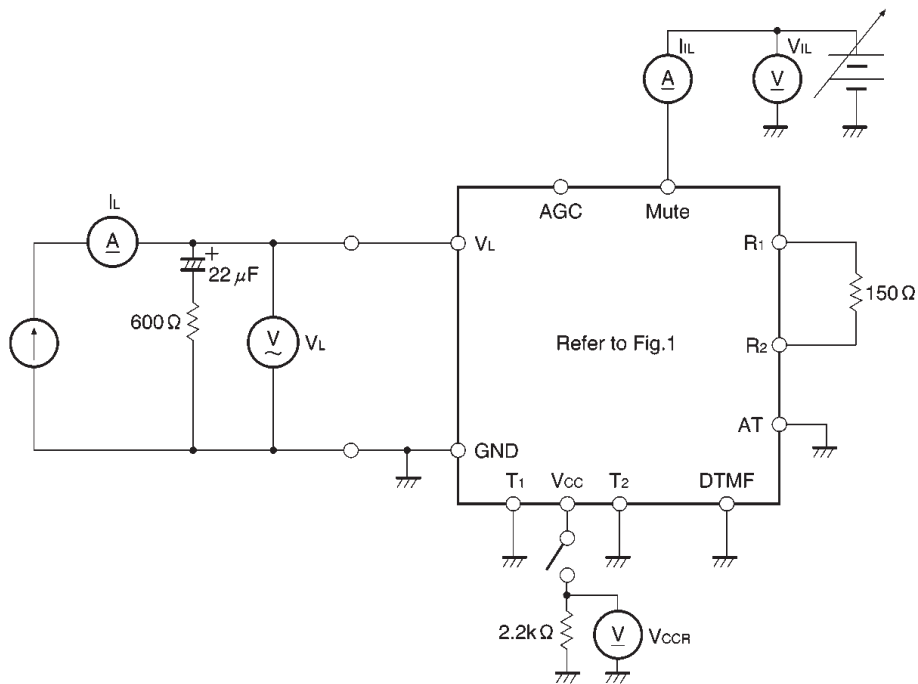

Fig. 2

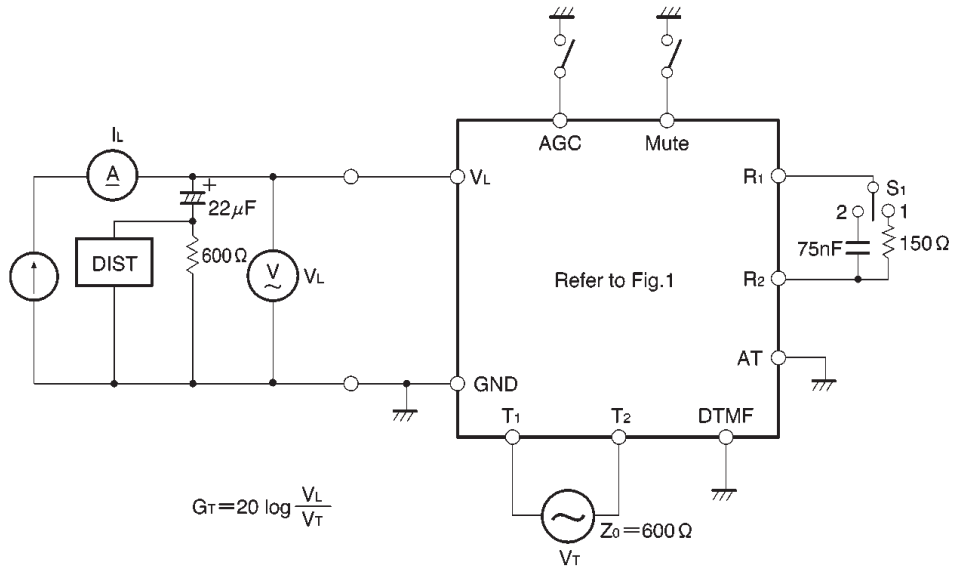

Fig. 3

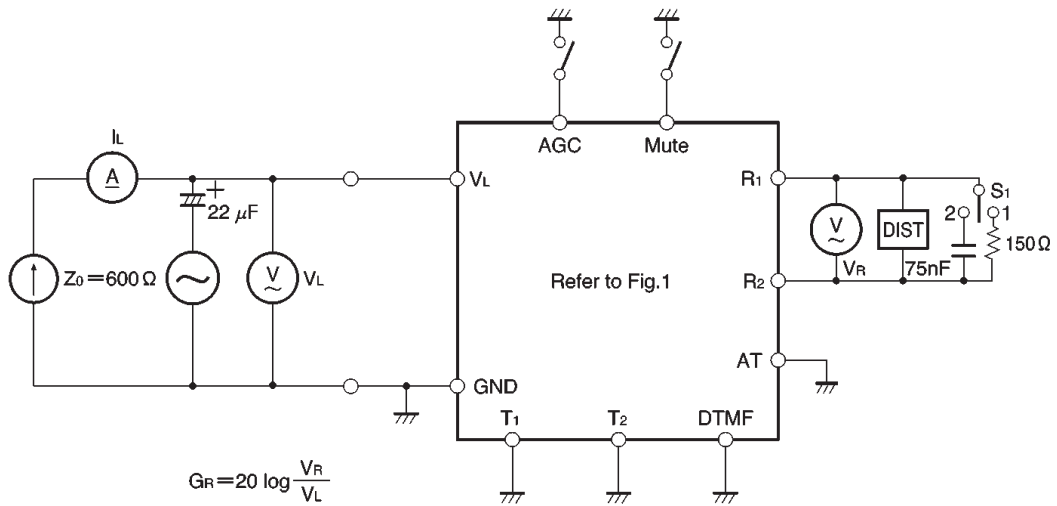

Fig. 4

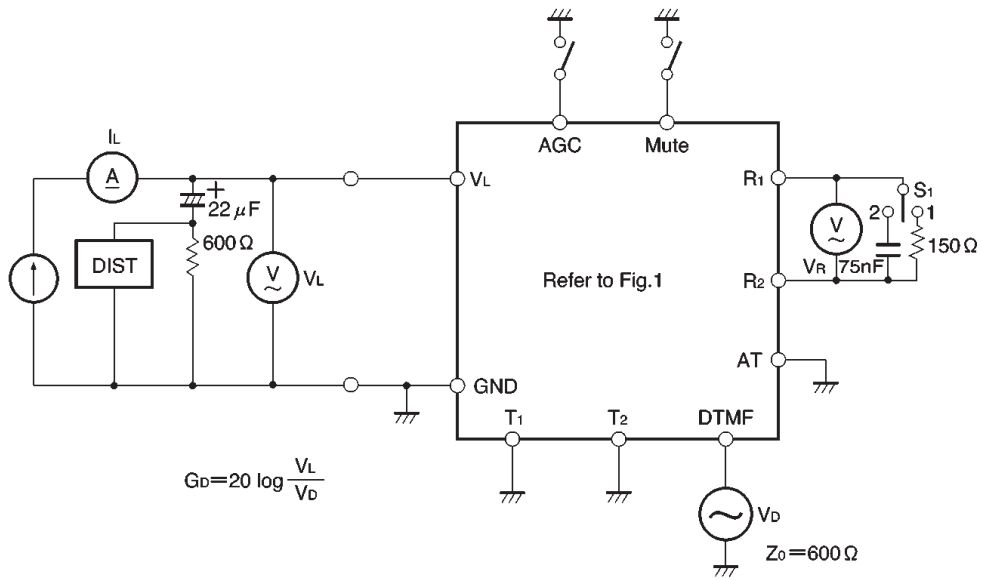

Fig. 5

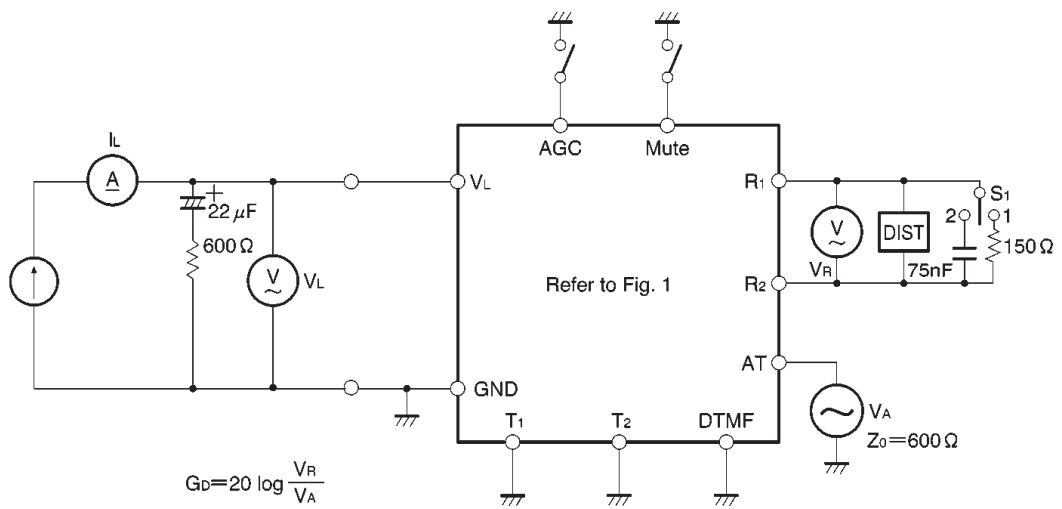

Fig. 6

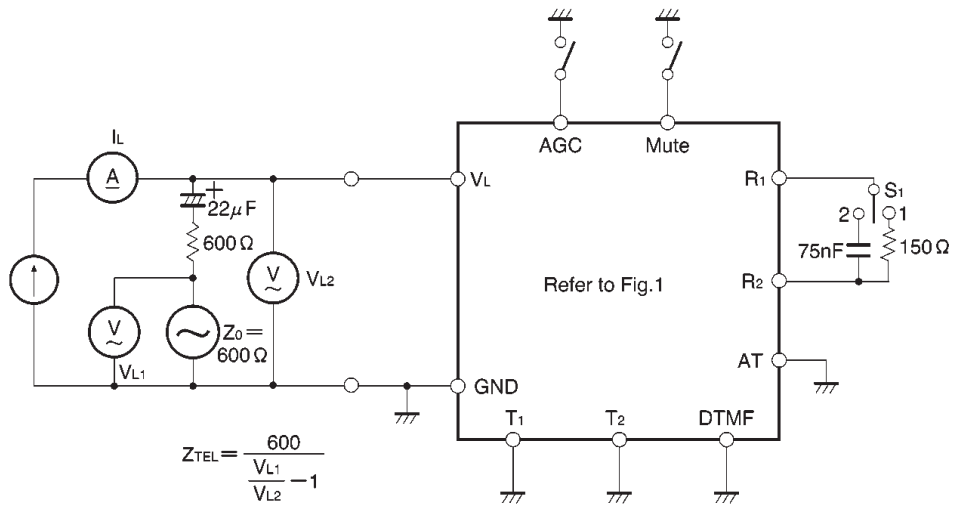

Fig. 7

● External dimensions (Units: mm)

