

Silicon NPN Power Transistors

2SD2634

DESCRIPTION

- With TO-3PML package
- High speed
- High breakdown voltage
- High reliability
- Built-in damper diode

APPLICATIONS

- Color TV horizontal deflection output

PINNING

PIN	DESCRIPTION
1	Base
2	Collector
3	Emitter

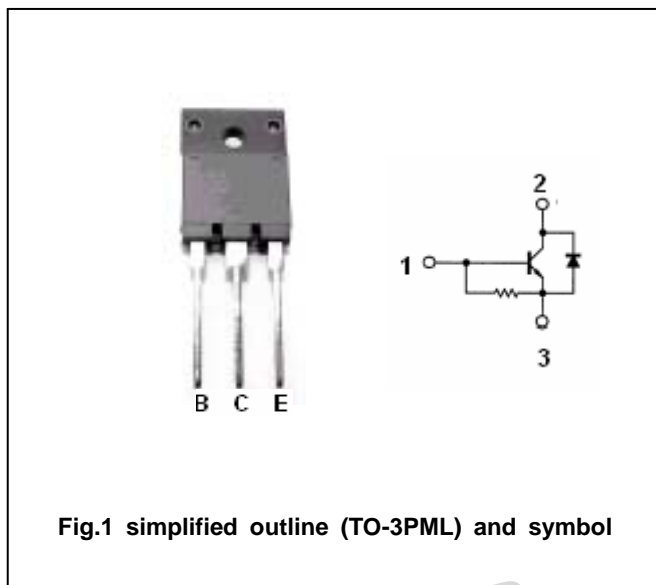

Fig.1 simplified outline (TO-3PML) and symbol

Absolute maximum ratings(Ta=25)

SYMBOL	PARAMETER	CONDITIONS	VALUE	UNIT
V_{CBO}	Collector-base voltage	Open emitter	1500	V
V_{CEO}	Collector-emitter voltage	Open base	800	V
V_{EBO}	Emitter-base voltage	Open collector	6	V
I_C	Collector current		8	A
I_{CM}	Collector current-peak		20	A
P_C	Collector power dissipation	$T_C=25$	65	W
			3	
T_j	Junction temperature		150	
T_{stg}	Storage temperature		-55~150	

Silicon NPN Power Transistors

2SD2634

CHARACTERISTICS

T_j=25 unless otherwise specified

SYMBOL	PARAMETER	CONDITIONS	MIN	TYP.	MAX	UNIT
V _{CEO(SUS)}	Collector-emitter sustaining voltage	I _C =100mA; I _B =0	800			V
V _{CEsat}	Collector-emitter saturation voltage	I _C =4.5A; I _B =0.9A			3	V
V _{BEsat}	Base-emitter saturation voltage	I _C =4.5A; I _B =0.9A			1.5	V
I _{CBO}	Collector cut-off current	V _{CB} =800V; I _E =0			10	μA
I _{CES}	Collector cut-off current	V _{CE} =1500V; R _{BE} =0			1.0	mA
I _{EBO}	Emitter cut-off current	V _{EB} =4V; I _C =0	40		130	mA
h _{FE-1}	DC current gain	I _C =5A; V _{CE} =5V	5		8	
h _{FE-2}	DC current gain	I _C =1A; V _{CE} =5V	10			
V _F	Diode forward voltage	I _{EC} =7A			2	V
t _f	Fall time	I _C =3A; R _L =66.7 I _{B1} =0.6A; -I _{B2} =1.2A; V _{CC} =200V			0.3	μs

Silicon NPN Power Transistors

2SD2634

PACKAGE OUTLINE

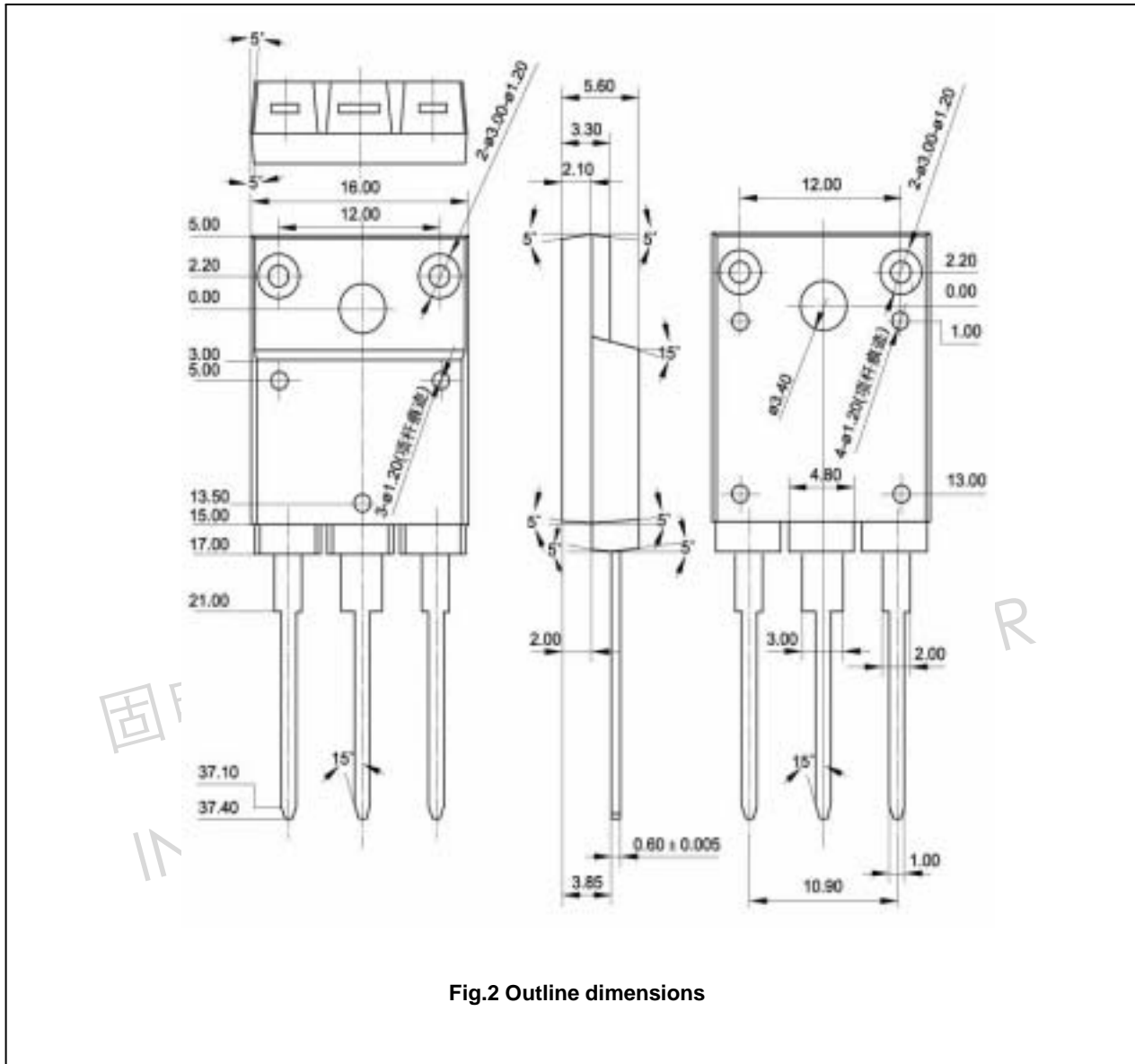

Fig.2 Outline dimensions

Silicon NPN Power Transistors

2SD2634

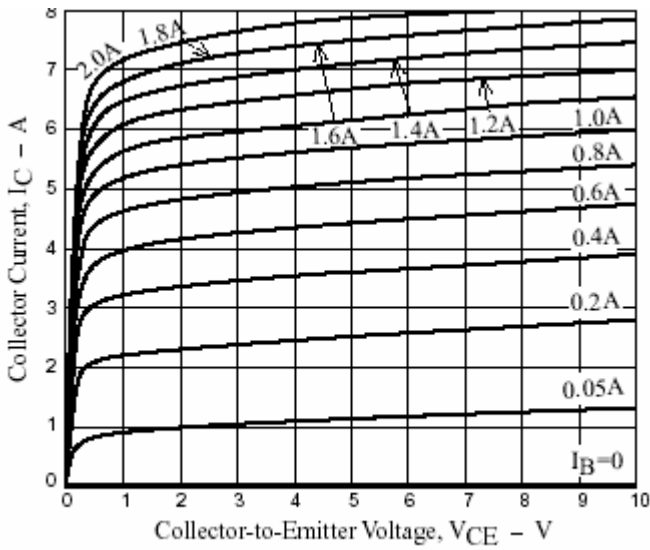

Fig.3 Static Characteristic

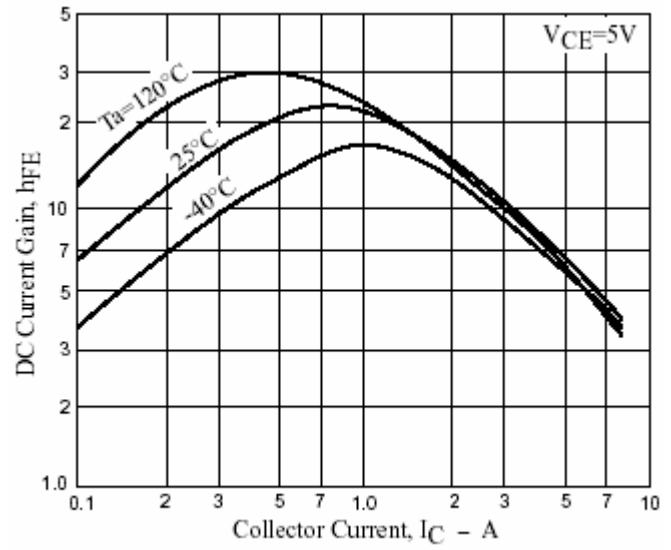

Fig.4 DC current Gain

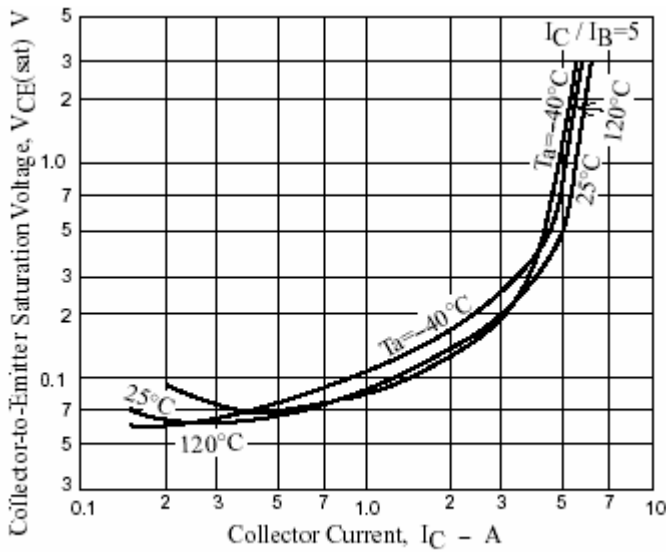

Fig.5 Collector-Emitter Saturation Voltage

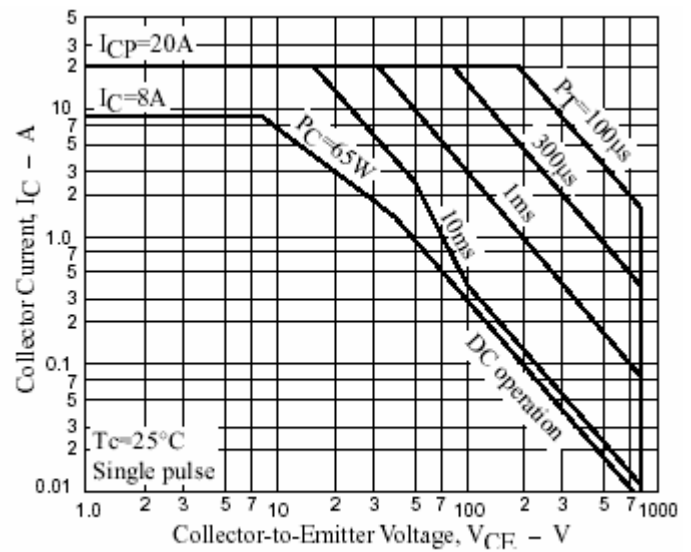

Fig.6 Safe Operating Area