

Silicon NPN Power Transistors

BU931

DESCRIPTION

- With TO-3 package
- High voltage
- DARLINGTON

APPLICATIONS

- High ruggedness electronic ignitions.
- High voltage ignition coil driver

PINNING(see fig.2)

PIN	DESCRIPTION
1	Base
2	Emitter
3	Collector

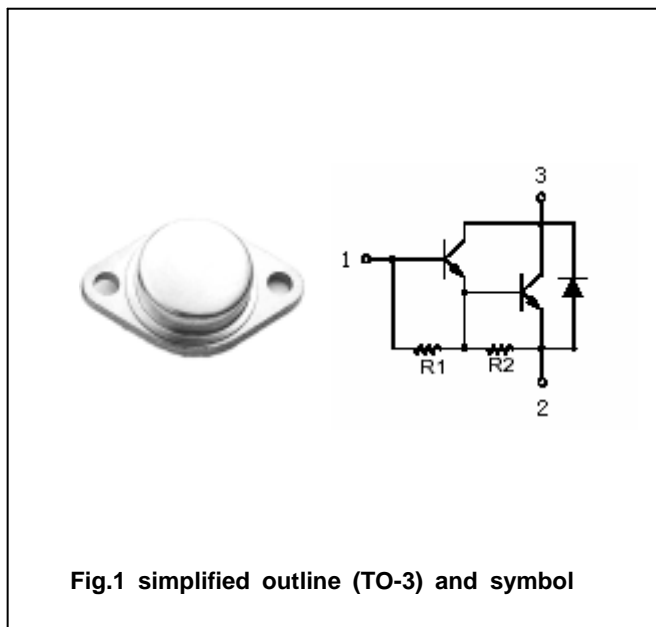

Fig.1 simplified outline (TO-3) and symbol

Absolute maximum ratings (Tc=25)

SYMBOL	PARAMETER	CONDITIONS	VALUE	UNIT
V _{CBO}	Collector-base voltage	Open emitter	500	V
V _{CEO}	Collector-emitter voltage	Open base	400	V
V _{EBO}	Emitter-base voltage	Open collector	5	V
I _C	Collector current		15	A
I _{CM}	Collector current-peak		30	A
I _B	Base current		1	A
I _{BM}	Base current (peak)		5	A
P _T	Total power dissipation	T _C =25	175	W
T _j	Junction temperature		-65~200	
T _{stg}	Storage temperature		-65~200	

THERMAL CHARACTERISTICS

SYMBOL	PARAMETER	MAX	UNIT
R _{th j-c}	Thermal resistance junction to case	1.0	/W

Silicon NPN Power Transistors

BU931

CHARACTERISTICS

T_j=25 unless otherwise specified

SYMBOL	PARAMETER	CONDITIONS	MIN	TYP.	MAX	UNIT
V _{CE0(SUS)}	Collector-emitter sustaining voltage	I _C =0.1A; I _B =0; L=10mH	400			V
V _{CEsat-1}	Collector-emitter saturation voltage	I _C =7A; I _B =70mA			1.6	V
V _{CEsat-2}	Collector-emitter saturation voltage	I _C =8 A; I _B =100mA			1.8	V
V _{CEsat-3}	Collector-emitter saturation voltage	I _C =10 A; I _B =250mA			1.8	V
V _{BEsat-1}	Base-emitter saturation voltage	I _C =7A; I _B =70mA			2.2	V
V _{BEsat-2}	Base-emitter saturation voltage	I _C =8 A; I _B =100mA			2.4	V
V _{BEsat-3}	Base-emitter saturation voltage	I _C =10A; I _B =250mA			2.5	V
I _{CEs}	Collector cut-off current	V _{CE} =500V; V _{BE} =0 T _j =125			0.1 0.5	mA
I _{CEO}	Collector cut-off current	V _{CE} =450V; I _B =0 T _j =125			0.1 0.5	mA
I _{EBO}	Emitter cut-off current	V _{EB} =5V; I _C =0			20	mA
h _{FE}	DC current gain	I _C =5A ; V _{CE} =10V	300			
V _F	Diode forward voltage	I _F =10A			2.5	V

PACKAGE OUTLINE

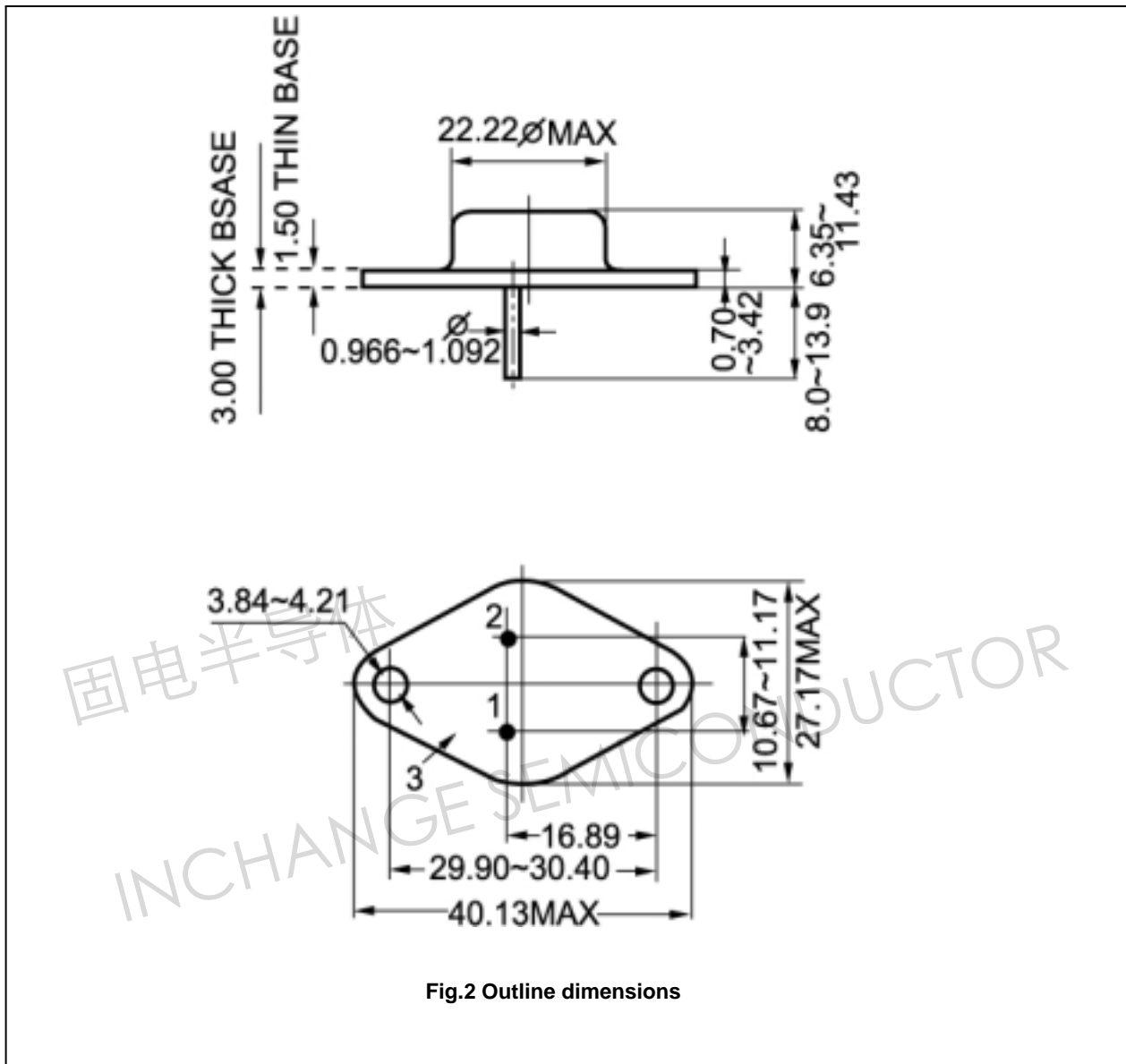

Fig.2 Outline dimensions