

KPBL-3025YSGC

YELLOW

SUPER BRIGHT GREEN

### Features

- 3.0mmx2.5mm SMT LED, 1.4mm THICKNESS.
- LOW POWER CONSUMPTION.
- WIDE VIEWING ANGLE.
- IDEAL FOR BACK LIGHT AND INDICATOR.
- VARIOUS COLORS AND LENS TYPES AVAILABLE.
- INNER LENS TYPE
- PACKAGE : 2000PCS / REEL.

### Description

The Yellow source color devices are made with Gallium Arsenide Phosphide on Gallium Phosphide Yellow Light Emitting Diode.

The Super Bright Green source color devices are made with Gallium Phosphide Green Light Emitting Diode.

### Package Dimensions

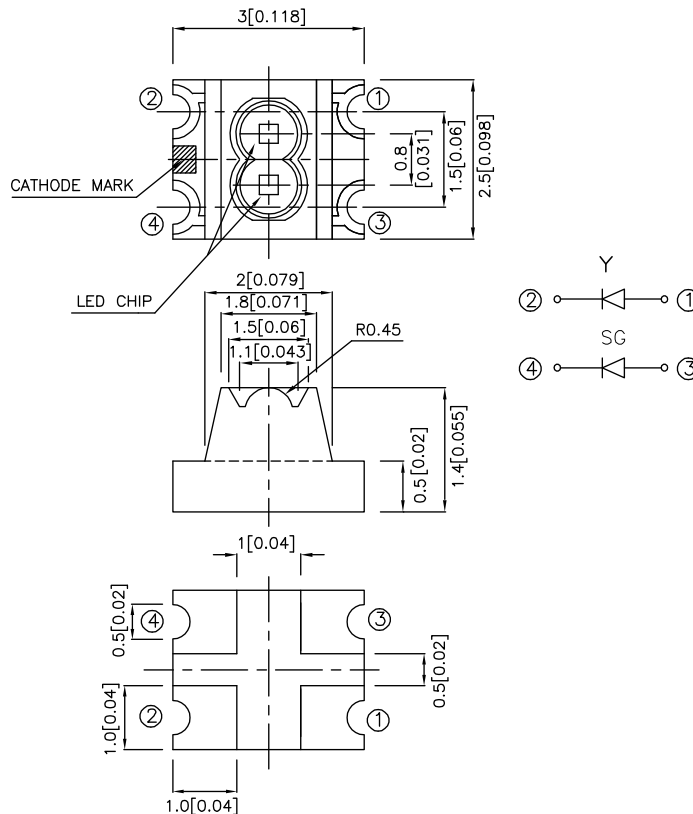

#### Notes:

1. All dimensions are in millimeters (inches).
2. Tolerance is  $\pm 0.2(0.008)$  unless otherwise noted.
3. Specifications are subject to change without notice.

## Selection Guide

| Part No.      | Dice                     | Lens Type   | Iv (mcd)<br>@ 20mA |      | Viewing<br>Angle |
|---------------|--------------------------|-------------|--------------------|------|------------------|
|               |                          |             | Min.               | Typ. | 2θ1/2            |
| KPBL-3025YSGC | YELLOW (GaAsP/GaP)       | WATER CLEAR | 4                  | 15   | 100°             |
|               | SUPER BRIGHT GREEN (GaP) |             | 7                  | 20   |                  |

Note:

1. θ1/2 is the angle from optical centerline where the luminous intensity is 1/2 the optical centerline value.

## Electrical / Optical Characteristics at TA=25°C

| Symbol            | Parameter                | Device                       | Typ.       | Max.       | Units | Test Conditions           |
|-------------------|--------------------------|------------------------------|------------|------------|-------|---------------------------|
| λ <sub>peak</sub> | Peak Wavelength          | Yellow<br>Super Bright Green | 590<br>565 |            | nm    | I <sub>F</sub> =20mA      |
| λ <sub>D</sub>    | Dominant Wavelength      | Yellow<br>Super Bright Green | 588<br>568 |            | nm    | I <sub>F</sub> =20mA      |
| Δλ <sub>1/2</sub> | Spectral Line Half-width | Yellow<br>Super Bright Green | 35<br>30   |            | nm    | I <sub>F</sub> =20mA      |
| C                 | Capacitance              | Yellow<br>Super Bright Green | 20<br>15   |            | pF    | V <sub>F</sub> =0V;f=1MHz |
| V <sub>F</sub>    | Forward Voltage          | Yellow<br>Super Bright Green | 2.1<br>2.2 | 2.5<br>2.5 | V     | I <sub>F</sub> =20mA      |
| I <sub>R</sub>    | Reverse Current          | All                          |            | 10         | uA    | V <sub>R</sub> = 5V       |

## Absolute Maximum Ratings at TA=25°C

| Parameter                     | Yellow         | Super Bright Green | Units |
|-------------------------------|----------------|--------------------|-------|
| Power dissipation             | 105            | 105                | mW    |
| DC Forward Current            | 30             | 25                 | mA    |
| Peak Forward Current [1]      | 140            | 140                | mA    |
| Reverse Voltage               | 5              |                    | V     |
| Operating/Storage Temperature | -40°C To +85°C |                    |       |

Note:

1. 1/10 Duty Cycle, 0.1ms Pulse Width.

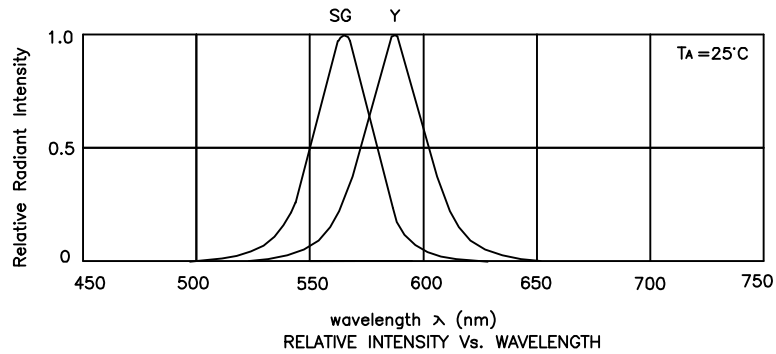

## KPBL-3025YSGC Yellow

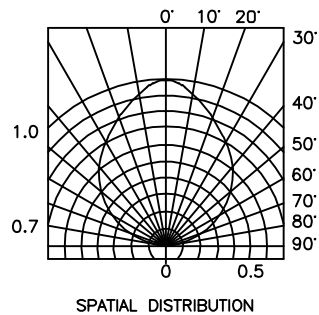
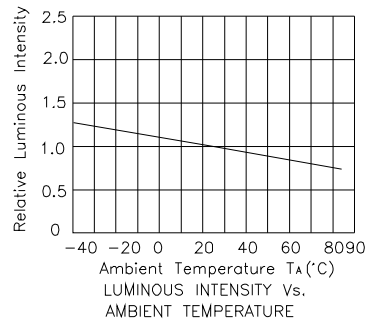
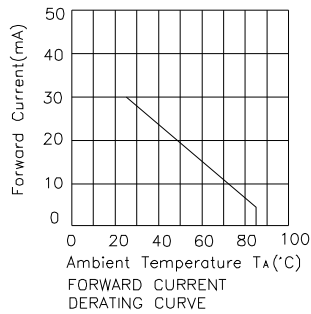
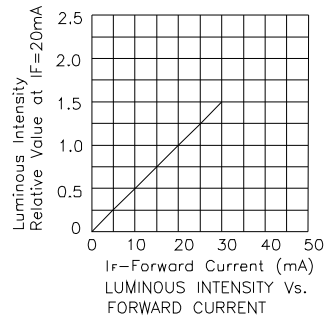
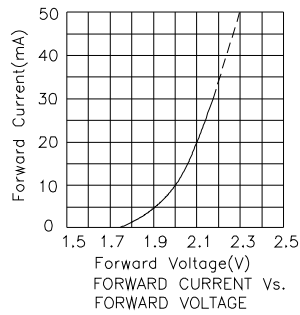

# Kingbright

## Super Bright Green

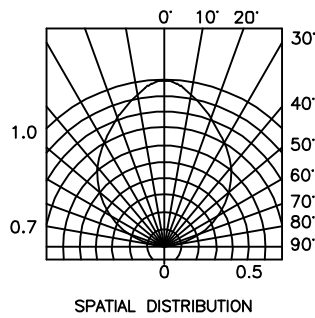
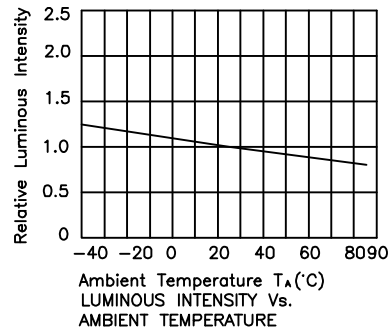
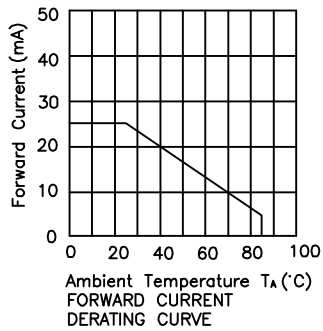
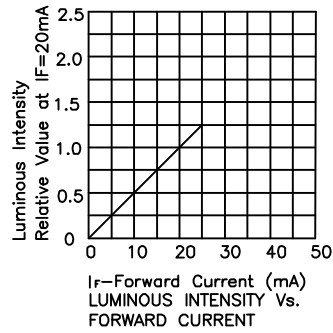
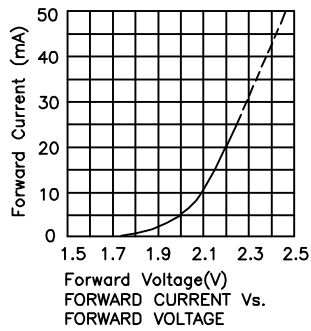

## KPBL-3025YSGC SMT Reflow Soldering Instructions

Number of reflow process shall be 2 times or less and cooling process to normal temperature is required between first and second soldering process.

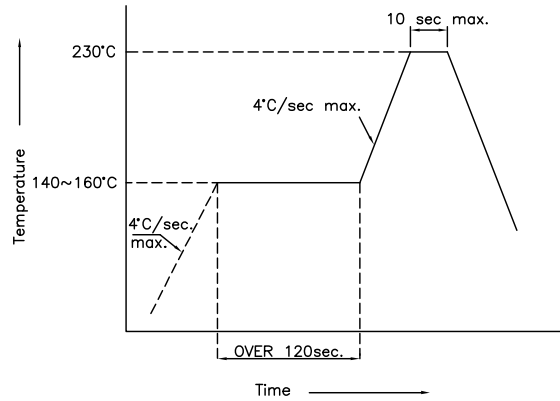

### Recommended Soldering Pattern (Units : mm)

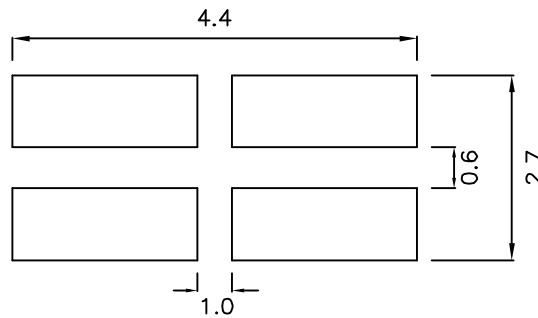

### Tape Specifications (Units : mm)

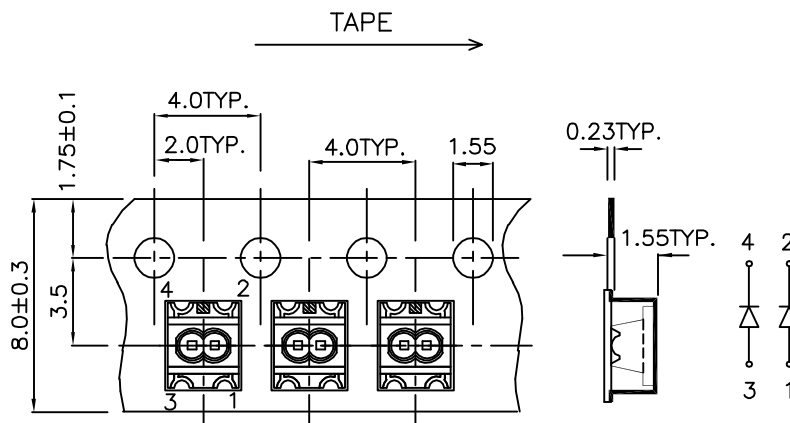

If special sorting is required (e.g. binning based on forward voltage, luminous intensity, or wavelength), the typical accuracy of the sorting process is as follows:

1. Wavelength: +/-1nm
2. Luminous Intensity: +/-15%
3. Forward Voltage: +/-0.1V

Note: Accuracy may depend on the sorting parameters.