

Silicon NPN Power Transistors

BU931R BU932R

DESCRIPTION

- With TO-3 package
- DARLINGTON

APPLICATIONS

- Automotive ignition applications
- Inverters circuits for motor controls

PINNING (See Fig.2)

PIN	DESCRIPTION
1	Base
2	Emitter
3	Collector

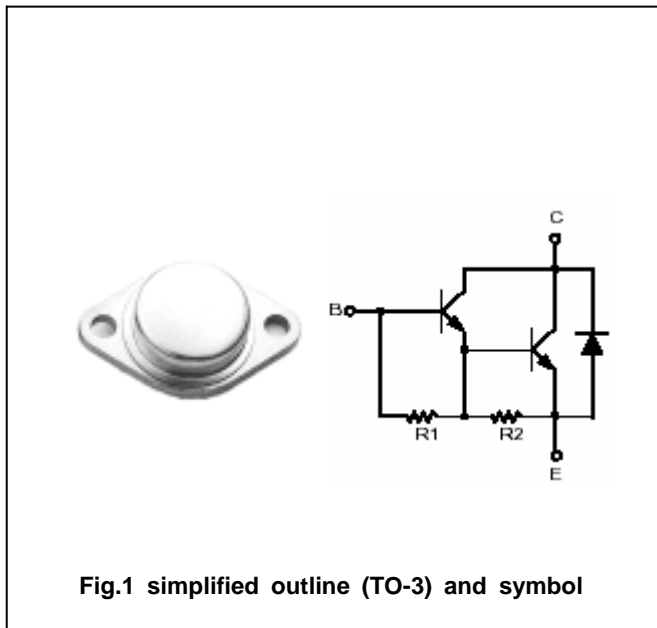

Fig.1 simplified outline (TO-3) and symbol

Absolute maximum ratings(Ta=25)

SYMBOL	PARAMETER	CONDITIONS	VALUE	UNIT
V _{CB0}	Collector-base voltage	BU931R	450	V
		BU932R	500	
V _{CEO}	Collector-emitter voltage	BU931R	400	V
		BU932R	450	
V _{EBO}	Emitter-base voltage	Open collector	5	V
I _C	Collector current		15	A
I _{CM}	Collector current-peak		30	A
I _B	Base current		1	A
I _{BM}	Base current-peak		5	A
P _T	Total power dissipation	T _C 25	175	W
T _j	Junction temperature		200	
T _{stg}	Storage temperature		-40~200	

THERMAL CHARACTERISTICS

SYMBOL	PARAMETER	VALUE	UNIT
R _{th j-c}	Thermal resistance from junction to case	1.0	/W

Silicon NPN Power Transistors

BU931R BU932R

CHARACTERISTICS

T_j=25 unless otherwise specified

SYMBOL	PARAMETER		CONDITIONS	MIN	TYP.	MAX	UNIT
V _{CEO}	Collector-emitter sustaining voltage	BU931R	I _C =100mA ; I _B =0	400			V
		BU932R		450			
V _{CEsat-1}	Collector-emitter saturation Voltage Only for BU931R		I _C =7A; I _B =70mA			1.6	V
V _{CEsat-2}	Collector-emitter saturation voltage	BU931R	I _C =8A; I _B =100mA			1.8	V
		BU932R	I _C =8A; I _B =150mA				
V _{CEsat-3}	Collector-emitter saturation Voltage Only for BU931R		I _C =10A; I _B =250mA			1.8	V
V _{BEsat-1}	Base-emitter saturation voltage	BU931R	I _C =8A; I _B =100mA			2.2	V
		BU932R	I _C =8A; I _B =150mA				
V _{BEsat-2}	Base-emitter saturation voltage Only for BU931R		I _C =10A; I _B =250mA			2.5	V
I _{CEO}	Collector cut-off current	BU931R	V _{CE} =400V ; I _B =0			1.0	mA
		BU932R	V _{CE} =450V ; I _B =0				
I _{CES}	Collector cut-off current	BU931R	V _{CE} =400V ; V _{BE} =0 T _C =125			1.0 5.0	mA
		BU932R	V _{CE} =450V ; V _{BE} =0 T _C =125			1.0 5.0	
I _{EBO}	Emitter cut-off current		V _{EB} =5V; I _C =0			50	mA
h _{FE}	DC current gain		I _C =5A ; V _{CE} =10V	300			
V _F	Diode forward voltage		I _F =10A			2.8	V

Switching times

t _s	Storage time	I _C =7A ; I _B =70mA ; V _{BE} =0; R _{BE} =47 V _{CC} =12V, V _{clamp} =300V; L=7mH		15		μs
t _f	Fall time			0.5		μs

Silicon NPN Power Transistors

BU931R BU932R

PACKAGE OUTLINE

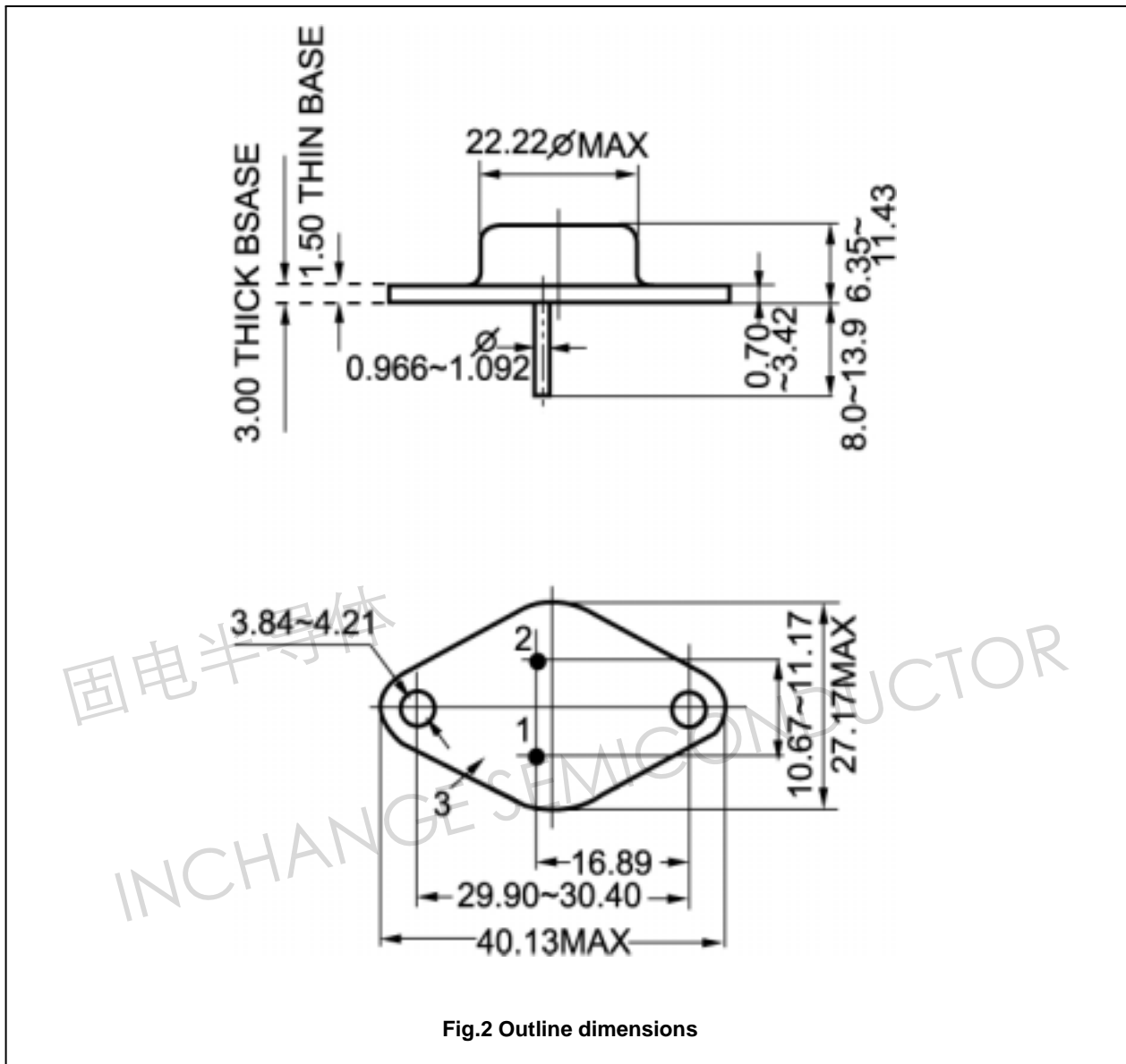

Fig.2 Outline dimensions