

Silicon NPN Power Transistors

BU506

DESCRIPTION

- With TO-220C package
- High voltage
- High-speed switching

APPLICATIONS

- Horizontal deflection circuits of colour TV receivers.
- Line-operated switch-mode applications.

PINNING

PIN	DESCRIPTION
1	Base
2	Collector;connected to mounting base
3	Emitter

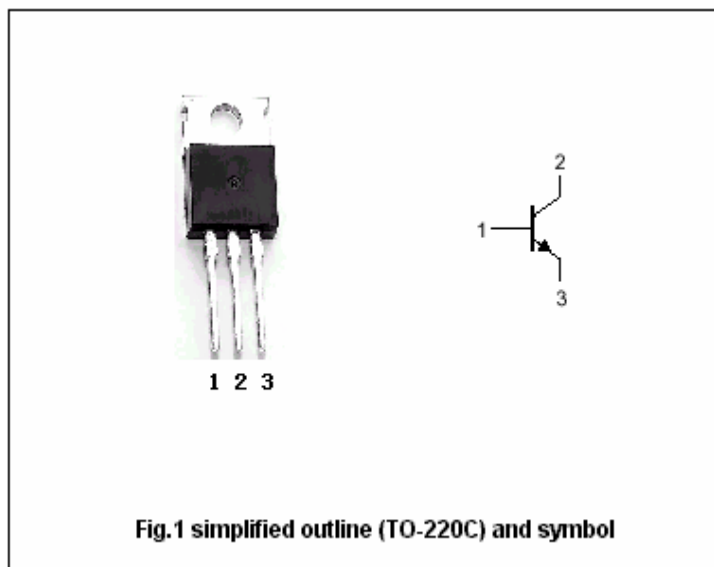

Absolute maximum ratings (Ta=25)

SYMBOL	PARAMETER	CONDITIONS	VALUE	UNIT
V_{CBO}	Collector-base voltage	Open emitter	1500	V
V_{CEO}	Collector-emitter voltage	Open base	700	V
V_{EBO}	Emitter-base voltage	Open collector	6	V
I_C	Collector current (DC)		5	A
I_{CM}	Collector current (Pulse)		8	A
I_B	Base current		3	A
I_{BM}	Base current(peak)		5	A
P_C	Collector power dissipation	$T_C=25$	100	W
T_j	Junction temperature		150	
T_{stg}	Storage temperature		-65-150	

Silicon NPN Power Transistors

BU506

CHARACTERISTICS

T_j=25 unless otherwise specified

SYMBOL	PARAMETER	CONDITIONS	MIN	TYP.	MAX	UNIT
V _{CEO(SUS)}	Collector-emitter sustaining voltage	I _C =100mA; I _B =0	700			V
V _{CEsat}	Collector-emitter saturation voltage	I _C =3A; I _B =1.33A			1.0	V
V _{BEsat}	Base-emitter saturation voltage	I _C =3A; I _B =1.33A			1.3	V
h _{FE}	DC current gain	I _C =0.1A; V _{CE} =5V	6	13	30	
I _{CES}	Collector cut-off current	V _{CE} =rated; V _{BE} =0 T _C =125			0.5 1.0	mA
I _{EBO}	Emitter cut-off current	V _{EB} =6V; I _C =0			10	mA

Switching times

t _s	Storage time	I _{CM} = 3 A; I _{B(end)} = 1A L _B = 12 μH		6.5		μs
t _f	Fall time			0.7		μs

PACKAGE OUTLINE

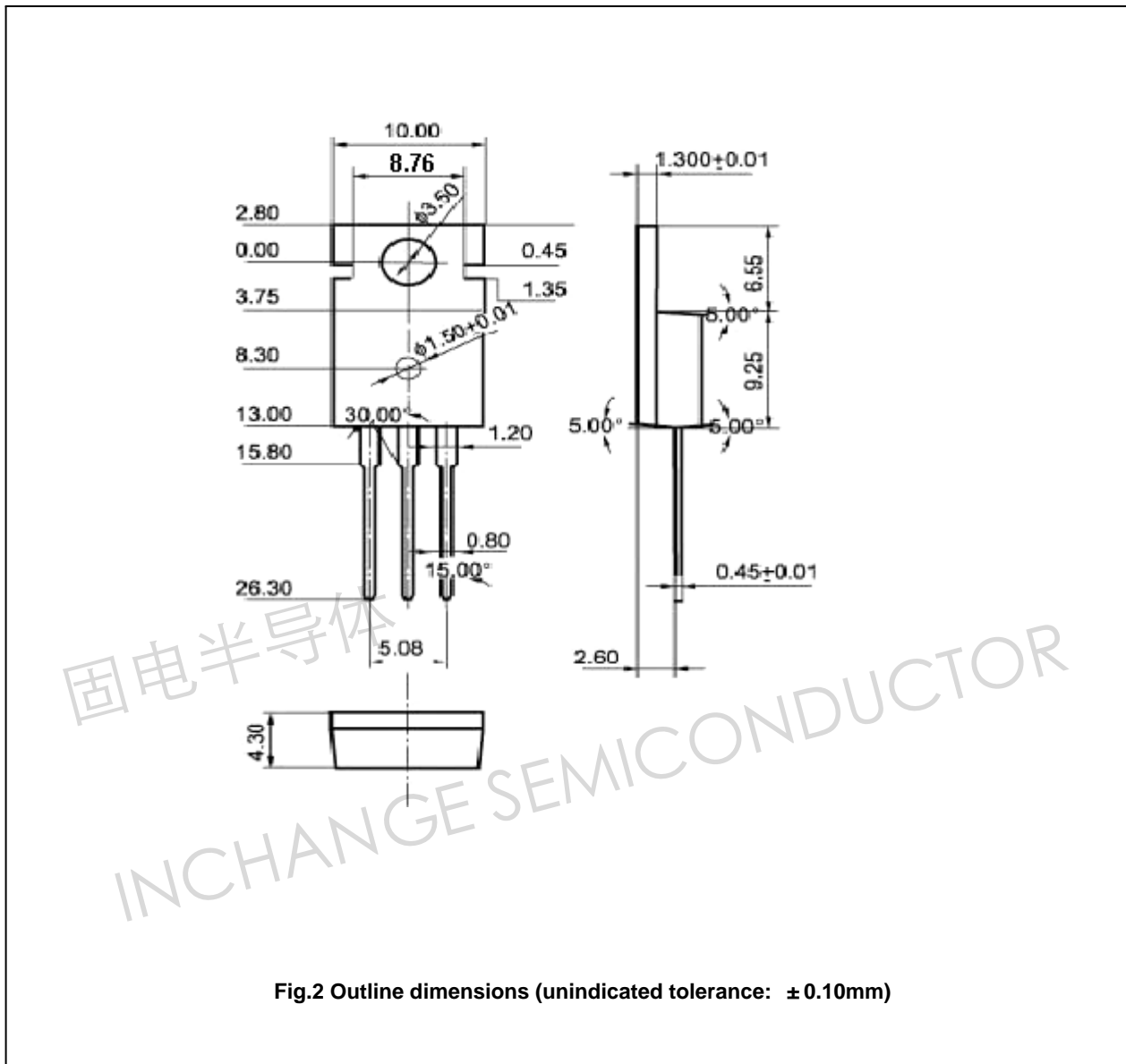

Fig.2 Outline dimensions (unindicated tolerance: ± 0.10 mm)