

Dual preamplifier with ALC

BA3306

The BA3306 is a dual preamplifier with ALC designed for use in stereo radio-cassette recorders and tape recorders. It comes in a compact 9-pin SIP package and has two record/playback preamplifiers, and an ALC circuit. The preamplifiers have high gain and low distortion, and can be directly coupled to the tape head without coupling capacitors. This prevents tape head magnetization and “pop” noise generation.

The ALC circuit has good channel balance and large dynamic range and can be constructed with addition of just an external detector and time constant circuit.

The IC also includes a power-on mute circuit that suppresses “pop” noise generation.

●Applications

Stereo radio cassette players

●Features

- 1) Wide operating power supply voltage range ($V_{CC} = 4.5V$ to $14V$).
- 2) Low current dissipation ($I_Q = 2.5mA$).
- 3) High gain ($G_{VO} = 80dB$).
- 4) Low distortion (THD = 0.1%).
- 5) Low noise ($V_{NIN} = 1\mu V_{rms}$).
- 6) Input coupling capacitors and not necessary.
- 7) Good ALC channel balance.
- 8) Power-on mute circuit.

●Block diagram

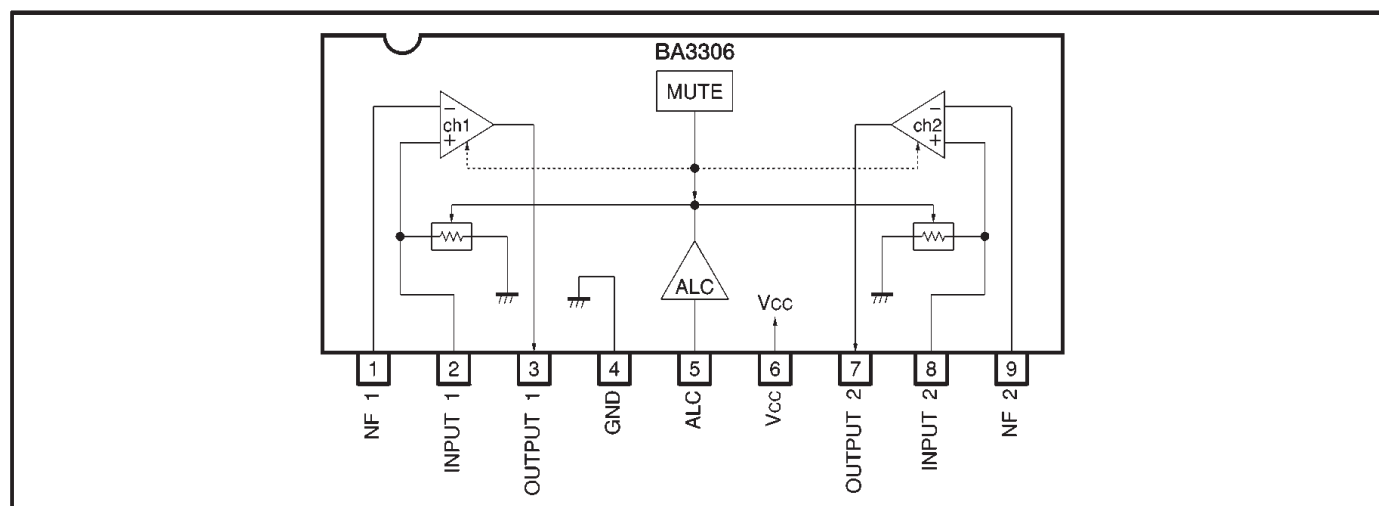

●Absolute maximum ratings ($T_a = 25^\circ C$)

Parameter	Symbol	Limits	Unit
Power supply voltage	V_{CC}	16	V
Power dissipation	P_d	950*	mW
Operating temperature	T_{opr}	$-25 \sim +75$	$^\circ C$
Storage temperature	T_{stg}	$-55 \sim +125$	$^\circ C$

* Reduced by 9.5mW for each increase in T_a of $1^\circ C$ over $25^\circ C$.

● Recommended operating conditions (Ta = 25°C)

Parameter	Symbol	Min.	Typ.	Max.	Unit
Power supply voltage	V _{CC}	4.5	7	14	V

● Electrical characteristics (unless otherwise noted, Ta = 25°C, V_{CC} = 7V, and f = 1kHz)

Parameter	Symbol	Min.	Typ.	Max.	Unit	Conditions
Quiescent current	I _Q	1.5	2.5	4.0	mA	V _{IN} =0V _{rms}
Open loop voltage gain	G _{vo}	70	80	—	dB	V _{OUT} =-10dBV
Total harmonic distortion	THD	—	0.1	0.3	%	NAB 34dB, V _{OUT} =40mV _{rms}
Input resistance	R _{IN}	15	25	45	kΩ	—
Maximum output voltage	V _{OM}	0.6	1.2	—	V _{rms}	THD=1%
Input conversion-noise voltage	V _{NIN}	—	1.0	2.0	μV _{rms}	R _g =2.2kΩ, BPF=20Hz~20kHz
ALC Channel balance	ΔALC	—	0	2.5	dB	V _{IN} =-60dBV, -30dBV

● Measurement circuit

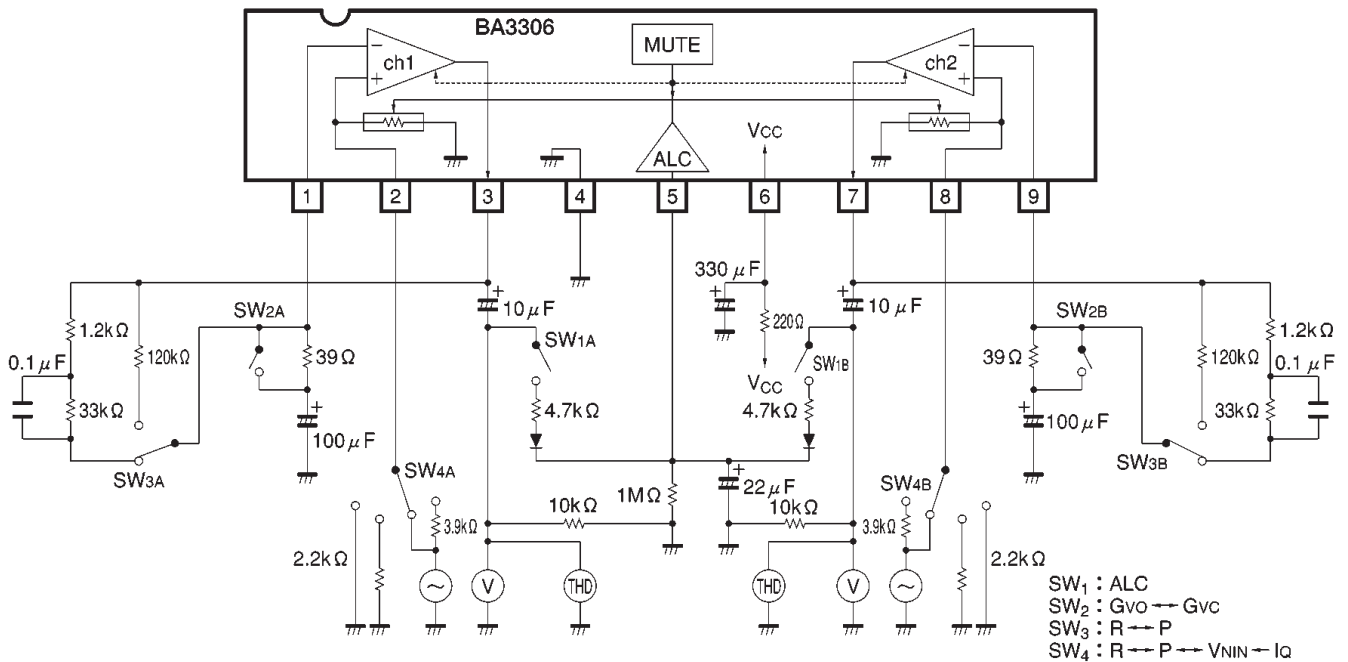

Fig.1

●Application example

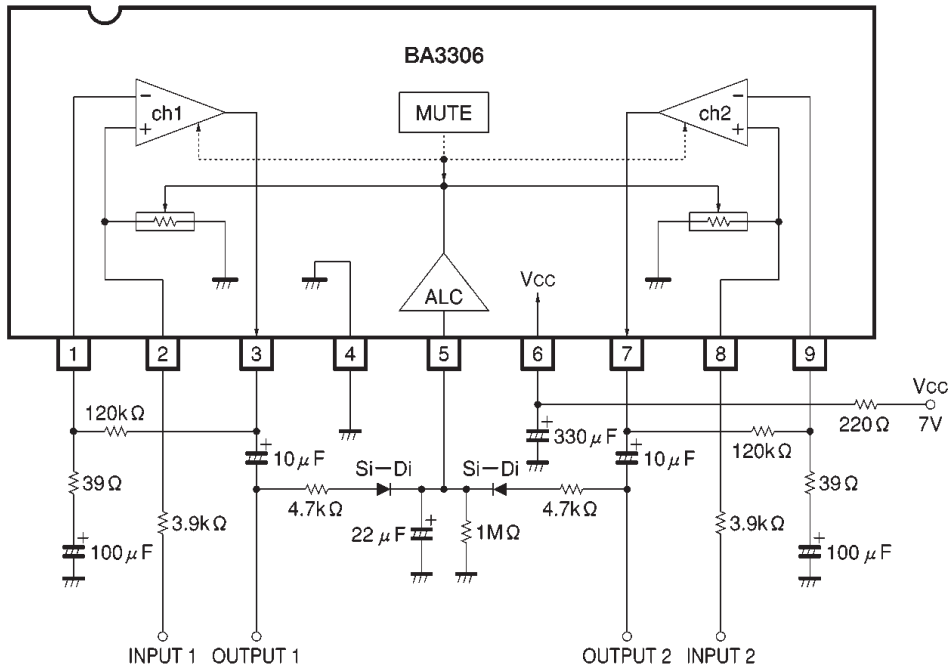

Fig.2

●Circuit operation

(1) Recording (See Fig. 3)

For recording, insert an attenuation resistor (3.9kΩ recommended) into the input line.

The ALC timing is determined by the time constant of the circuit connected between pin 5 and GND. The attack time is set the capacitor (22µF) and the resistor (4.7kΩ) that is connected in series with the diode. The recovery time is set by this capacitor and the resistor (1MΩ) connected to pin 5.

(2) Playback (See Fig. 4)

For playback, the amplifier is used as a NAB equalizer amplifier. The ALC circuit is not needed at this time, so pin 5 is earthed. The negative feedback time constant settings are Hi - 120µs and Lo - 3180µs.

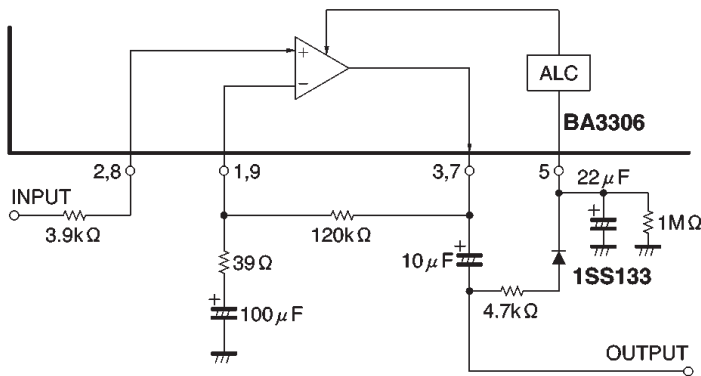

Fig. 3

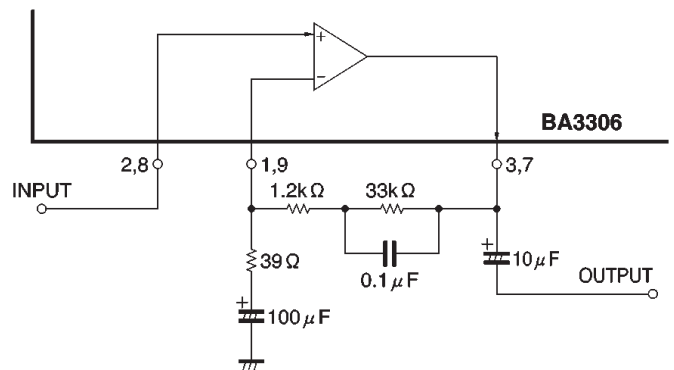

Fig. 4

●Electrical characteristics curves

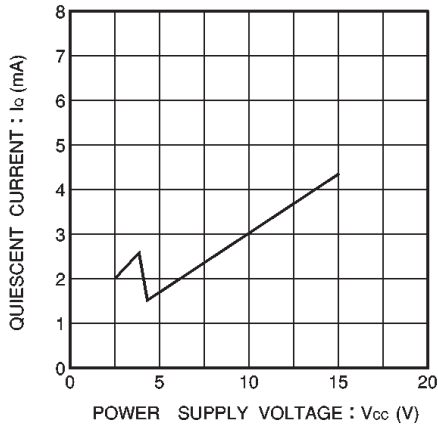

Fig. 5 Quiescent current vs. power supply voltage

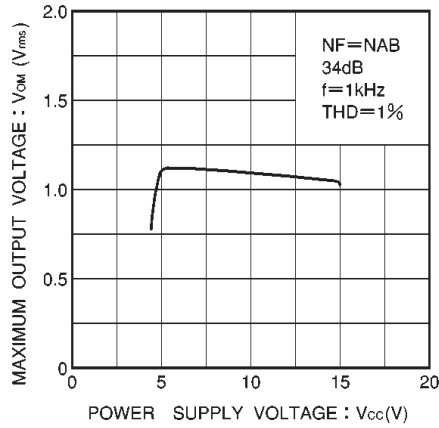

Fig. 6 Maximum output voltage vs. power supply voltage

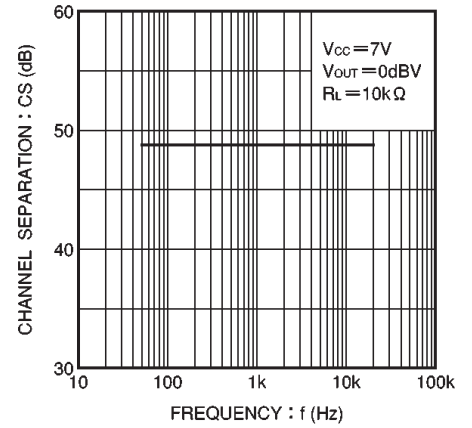

Fig. 7 Channel separation vs. signal frequency

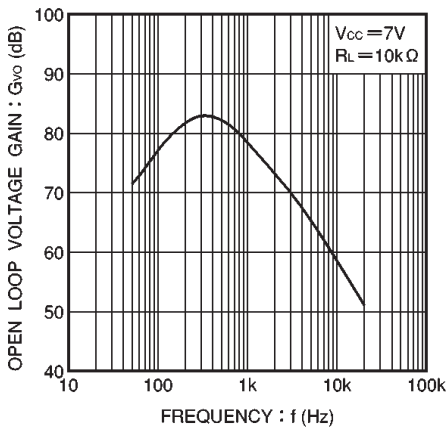

Fig. 8 Open loop voltage gain vs. signal frequency

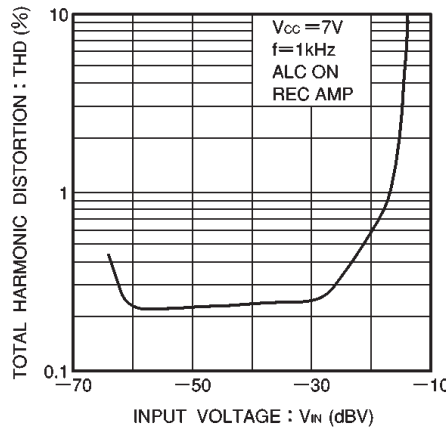

Fig. 9 Total harmonic distortion vs. input voltage

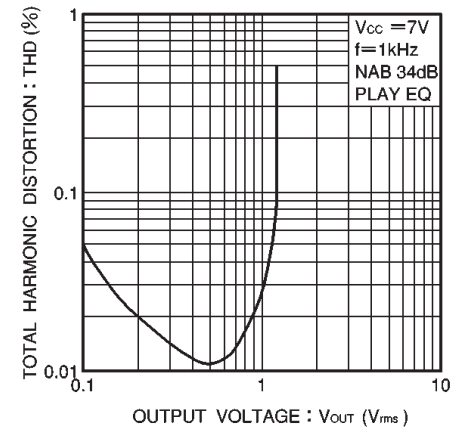

Fig. 10 Total harmonic distortion vs. output voltage

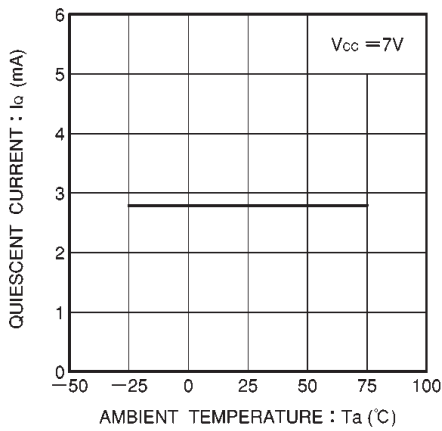

Fig. 11 Quiescent current vs. ambient temperature

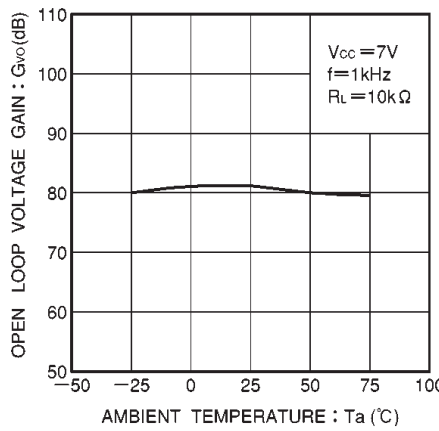

Fig. 12 Open loop voltage gain vs. ambient temperature

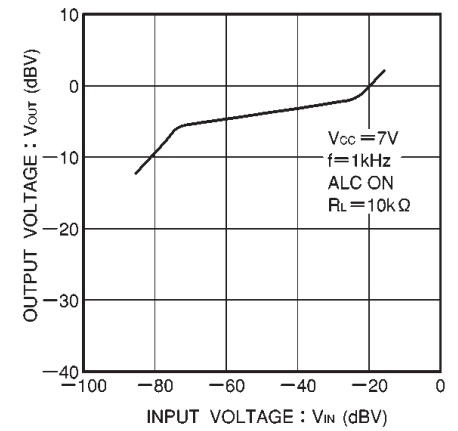

Fig. 13 ALC I/O characteristics

● External dimensions (Units: mm)

