

Silicon NPN Power Transistors

BUH517D

DESCRIPTION

- With TO-3PML package
- High voltage,high speed
- Low collector saturation voltage

APPLICATIONS

- Horizontal deflection stage in standard and high resolution displays for TV's and monitors.
- Switching power supplies for TV's and monitors.

PINNING

PIN	DESCRIPTION
1	Base
2	Collector
3	Emitter

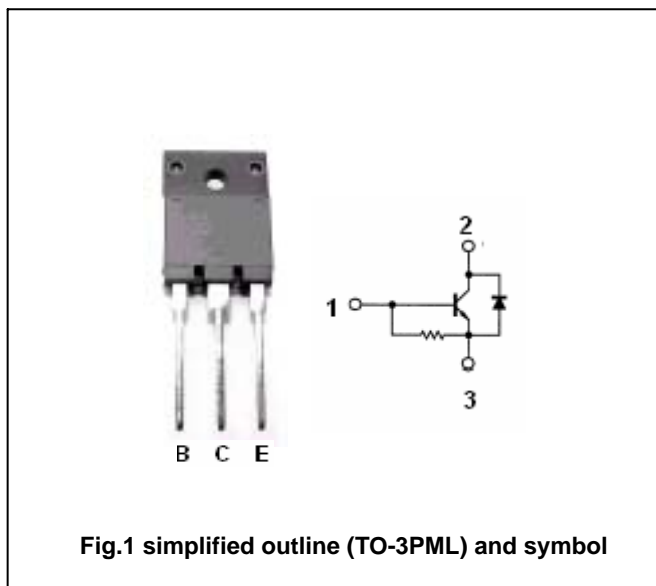

Fig.1 simplified outline (TO-3PML) and symbol

Absolute maximum ratings(Ta=25)

SYMBOL	PARAMETER	CONDITIONS	VALUE	UNIT
V_{CBO}	Collector-base voltage	Open emitter	1200	V
V_{CEO}	Collector-emitter voltage	Open base	700	V
V_{EBO}	Emitter-base voltage	Open collector	10	V
I_C	Collector current (DC)		8	A
I_{CM}	Collector current (Pulse)	$t_p < 5ms$	15	A
I_B	Base current (DC)		5	A
I_{BM}	Base current (Pulse)	$t_p < 5ms$	8	A
P_{tot}	Total power dissipation	$T_C = 25$	60	W
T_j	Operating junction temperature		150	
T_{stg}	Storage temperature		-65~150	

Silicon NPN Power Transistors

BUH517D

CHARACTERISTICS

T_j=25 unless otherwise specified

SYMBOL	PARAMETER	CONDITIONS	MIN	TYP.	MAX	UNIT
V _{CEO(SUS)}	Collector-emitter sustaining voltage	I _C =100mA; I _B =0	700			V
V _{CEsat}	Collector-emitter saturation voltage	I _C =5A ; I _B =1.25A			1.5	V
V _{BEsat}	Base-emitter saturation voltage	I _C =5A ; I _B =1.25A			1.3	V
I _{CES}	Collector cut-off current	V _{CE} =1200V; V _{BE} =0 T _j =125			1.0 2.0	mA
I _{EBO}	Emitter cut-off current	V _{EB} =5V; I _C =0			200	mA
h _{FE-1}	DC current gain	I _C =1A ; V _{CE} =5V	8		36	
h _{FE-2}	DC current gain	I _C =5A ; V _{CE} =5V	6			
V _F	Diode forward voltage	I _F =5A			2.0	V

THERMAL CHARACTERISTICS

SYMBOL	PARAMETER	MAX	UNIT
R _{th j-c}	Thermal resistance from junction to case	2.08	/W

Silicon NPN Power Transistors

BUH517D

PACKAGE OUTLINE

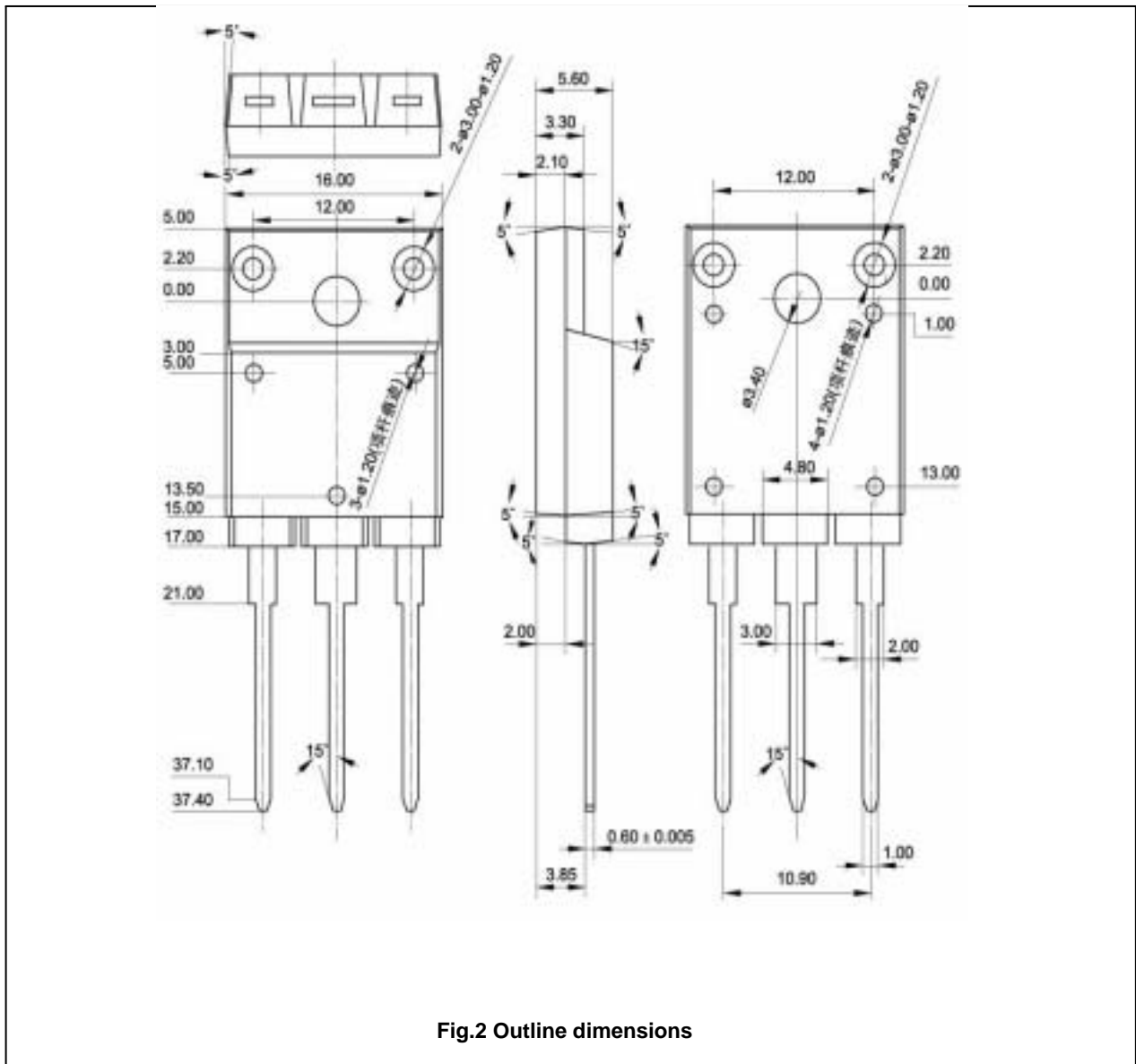

Fig.2 Outline dimensions