

Dual high-performance operational amplifier

NE/SA/SE5512

DESCRIPTION

The 5512 series of high-performance operational amplifiers provides very good input characteristics. These amplifiers feature low input bias and voltage characteristics such as a 108 op amp with improved CMRR and a high differential input voltage limit achieved through the use of a bias cancellation and PNP input circuits with collector-to-emitter clamping. The output characteristics are like those of a 741 op amp with improved slew rate and drive capability, yet have low supply quiescent current.

APPLICATIONS

- AC amplifiers
- RC active filters
- Transducer amplifiers
- DC gain block
- Battery operation
- Instrumentation amplifiers

FEATURES

- Low input bias $\pm 20\text{nA}$
- Low input offset current $\pm 20\text{nA}$
- Low input offset voltage <math>< 1\text{mV}</math>
- Low VOS temperature drift $5\mu\text{V}/^\circ\text{C}$
- Low input bias temperature drift $40\text{pA}/^\circ\text{C}$
- Low input voltage noise $30\text{nV}/\sqrt{\text{Hz}}$
- Low supply current $1.5\text{mA}/\text{amp}$
- High slew rate $1.0\text{V}/\mu\text{s}$
- High CMRR 100dB

PIN CONFIGURATIONS

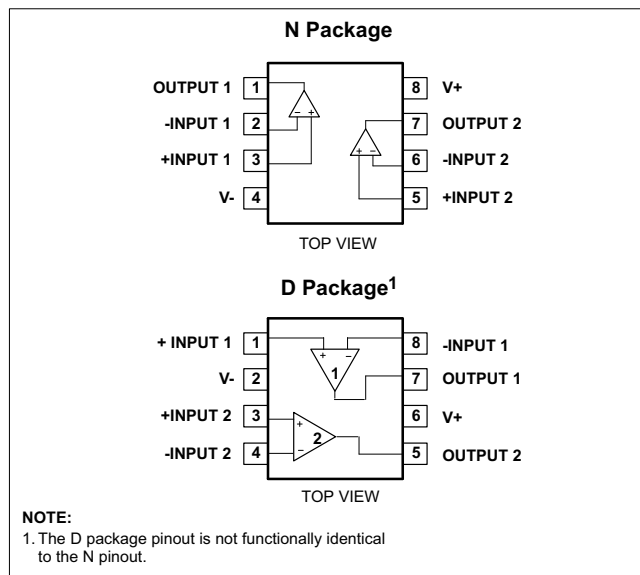

- High input impedance 100M Ω
- High PSRR 110dB
- High differential input voltage limit
- No crossover distortion
- Indefinite output short circuit protection
- Internally-compensated for unity gain
- 600 Ω drive capability
- MIL-STD processing available

ORDERING INFORMATION

DESCRIPTION	TEMPERATURE RANGE	ORDER CODE	DWG #
8-Pin Plastic Small Outline (SO) Package	0 to 70°C	NE5512D	0174C
8-Pin Plastic Dual In-Line Package (DIP)	0 to 70°C	NE5512N	0404B
8-Pin Plastic Small Outline (SO) Package	-40 to +85°C	SA5512D	0174C
8-Pin Plastic Dual In-Line Package (DIP)	-40 to +85°C	SA5512N	0404B
8-Pin Plastic Dual In-Line Package (DIP)	-55 to +125°C	SE5512N	0404B

Dual high-performance operational amplifier

NE/SA/SE5512

ABSOLUTE MAXIMUM RATINGS

SYMBOL	PARAMETER	RATING	UNIT
V _{CC}	Supply voltage	±16	V
P _{D MAX}	Maximum power dissipation, T _A =25°C (still air) ¹ N package D package	1212 800	mW mW
T _A	Operating ambient temperature range NE5512 SA5512 SE5512	0 to +70 -40 to +85 -55 to +125	°C °C °C
T _{STG}	Storage temperature range	-65 to +150	°C
T _{SOLD}	Lead soldering temperature (10sec max)	300	°C

NOTES:

- The following derating factors should be applied above 25°C
N package at 9.7mW/°C
D package at 6.4mW/°C

Dual high-performance operational amplifier

NE/SA/SE5512

ELECTRICAL PERFORMANCE CHARACTERISTICS $V_{CC} = \pm 15V$, $T_A = 25^\circ C$ over temperature range, unless otherwise specified.

SYMBOL	PARAMETER	TEST CONDITIONS	SE5512			NE/SA5512			UNIT
			Min	Typ	Max	Min	Typ	Max	
V_{OS}	Input offset voltage	$R_S=100\Omega$ $T_A=+25^\circ C$ Over temp.		0.7 1	2 3		1 1.5	5 6	mV
$\Delta V_{OS}/\Delta T$				4			5		$\mu V/^\circ C$
I_{OS}	Input offset current	$R_S=100k\Omega$ $T_A=+25^\circ C$ Over temp.		3 4	10 20		6 8	20 30	nA
$\Delta I_{OS}/\Delta T$				30			40		$pA/^\circ C$
I_{BIAS}	Input bias current	$R_S=100k\Omega$ $T_A=+25^\circ C$ Over temp.		3 4	10 20		6 8	20 30	nA
$\Delta I_{BIAS}/\Delta T$				30			40		$pA/^\circ C$
R_{IN}	Input resistance differential	$T_A=+25^\circ C$		100			100		M Ω
V_{CM}	Input common mode range	$T_A=+25^\circ C$ Over temp.	± 13.5 ± 13	± 13.7 ± 13.2		± 13.5 ± 13	± 13.7 ± 13.2		V
CMRR	Input common-mode rejection ratio	$V_{CC}=\pm 15V$ $V_{IN}=\pm 13.5V$ $T_A=+25^\circ C$ $V_{IN}=\pm 13V$ Over temp.	70	100		70	100		dB
A_V	Large-signal voltage gain	$R_L=2k\Omega$ $T_A=25^\circ C$ $V_O=\pm 10V$ over temp.	50 25	200		50 25	200		V/mV
SR	Slew rate	$T_A=25^\circ C$	0.6	1			1		V/ μs
GBW	Small-signal unity gain bandwidth	$T_A=25^\circ C$		3			3		MHz
θ_M	Phase margin	$T_A=25^\circ C$		45			45		degree
V_{OUT}	Output voltage swing	$R_L=2k\Omega$ $T_A=25^\circ C$ Over temp.	± 13 ± 12.5	± 13.5 ± 13		± 13 ± 12.5	± 13.5 ± 13		V
V_{OUT}	Output voltage swing	$R_L=600\Omega^1$ $T_A=25^\circ C$ Over temp.	± 10 ± 7.5	± 11.5 ± 9		± 10 ± 8	± 11.5 ± 9		V
I_{CC}	Power supply current	$R_L=Open$ $T_A=25^\circ C$ Over temp.		3.4 3.6	5 5.5		3.4 3.6	5 5.5	mA
PSRR	Power supply rejection ratio	Over temp.	80	100		80	100		dB
AA	Amplifier-to-amplifier coupling	$f=1kHz$ to $20kHz$, $T_A=25^\circ C$		-120			-120		dB
THD	Total harmonic distortion	$f=10kHz$ $T_A=25^\circ C$ $V_O=7V_{RMS}$		0.01			0.01		%
V_{NOISE}	Input noise voltage	$f=1kHz$ $T_A=25^\circ C$		30			30		nV/ \sqrt{Hz}
I_{NOISE}	Input noise current	$f=1kHz$ $T_A=25^\circ C$		0.2			0.2		pA/\sqrt{Hz}
I_{SC}	Short-circuit current	$\pm 15V$, $T_A=25^\circ C$		40			40		mA

NOTES:

1. Not to exceed maximum package power dissipation.

Dual high-performance operational amplifier

NE/SA/SE5512

EQUIVALENT SCHEMATIC

