

Glass Passivated Bridge Rectifiers

Reverse Voltage - 50 to 1000 Volts
Forward Current - 8.0 Amperes

Features

- Glass passivated chip
- Low forward voltage drop
- Ideal for printed circuit board
- High surge current capability
- Meet UL flammability classification 94V-0

Mechanical Data

- Polarity: Symbol marked on body
- Mounting position: Any

Applications

- General purpose use in AC/DC bridge full wave rectification, for SMPS, lighting ballaster, adapter, etc.

KBU

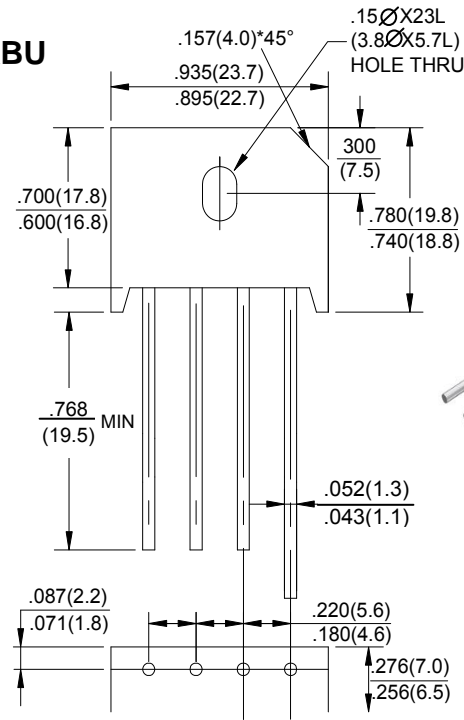

RoHS
COMPLIANT

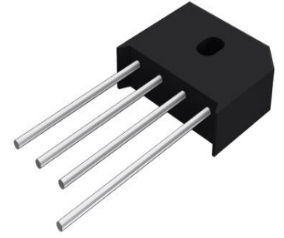

Package Outline Dimensions in Inches (Millimeters)

Maximum Ratings and Electrical Characteristics

Rating at 25°C ambient temperature unless otherwise specified.

Single phase, half wave, 60Hz, resistive or inductive load.

For capacitive load, derate current by 20%.

Characteristics	Symbol	KBU	KBU	KBU	KBU	KBU	KBU	KBU	Unit
		8005G	801G	802G	804G	806G	808G	810G	
Maximum Repetitive Peak Reverse Voltage	V _{RRM}	50	100	200	400	600	800	1000	V
Maximum RMS Voltage	V _{RMS}	35	70	140	280	420	560	700	V
Maximum DC Blocking Voltage	V _{DC}	50	100	200	400	600	800	1000	V
Maximum Average Forward Rectified Current at @T _c =100 °C (with heatsink)	I _(AV)	8.0							A
Rectified Current at @T _A =25 °C (without heatsink)		2.9							
Peak Forward Surge Current, 8.3mS Single Half Sine-Wave, Superimposed on Rated Load (JEDEC Method)	I _{FSM}	175							A
I ² t Rating for Fusing (t<8.3mS)	I ² t	127.1							A ² s
Peak Forward Voltage per Diode at 4.0A DC	V _F	1.1							V
Maximum DC Reverse Current at Rated @T _J =25°C	I _R	10							μA
DC Blocking Voltage per Diode @T _J =100°C		100							
Typical Junction Capacitance Per Diode (Note1)	C _J	250							pF
Operating Junction Temperature Range	T _J	-55 to +150							°C
Storage Temperature Range	T _{STG}	-55 to +150							°C

Notes: 1. Measured at 1.0 MHz and applied reverse voltage of 4.0V DC.

2. The typical data above is for reference only

Fig. 1 - Forward Current Derating Curve

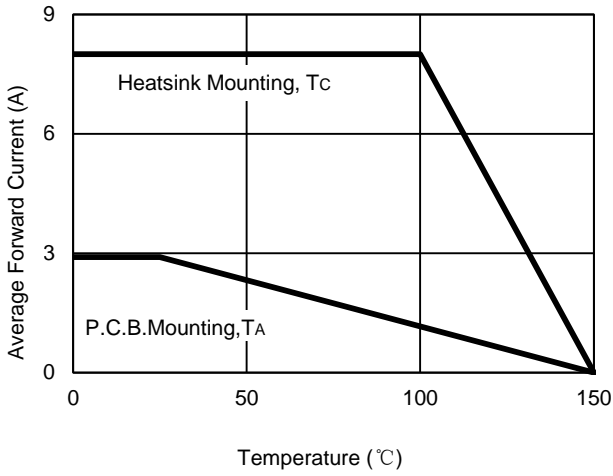

Fig. 2 - Maximum Non-Repetitive Surge Current

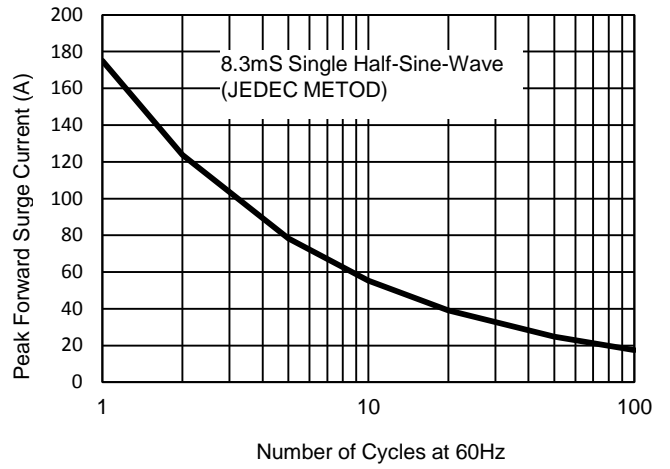

Fig. 3 - Typical Reverse Characteristics

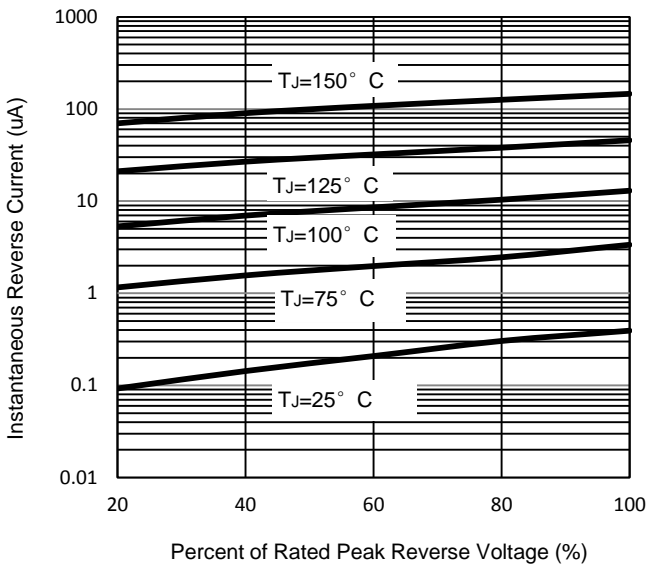

Fig. 4 - Typical Forward Characteristics

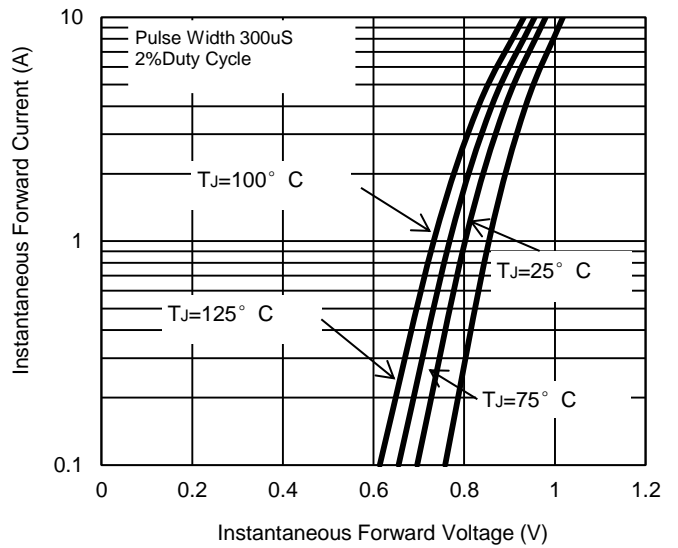
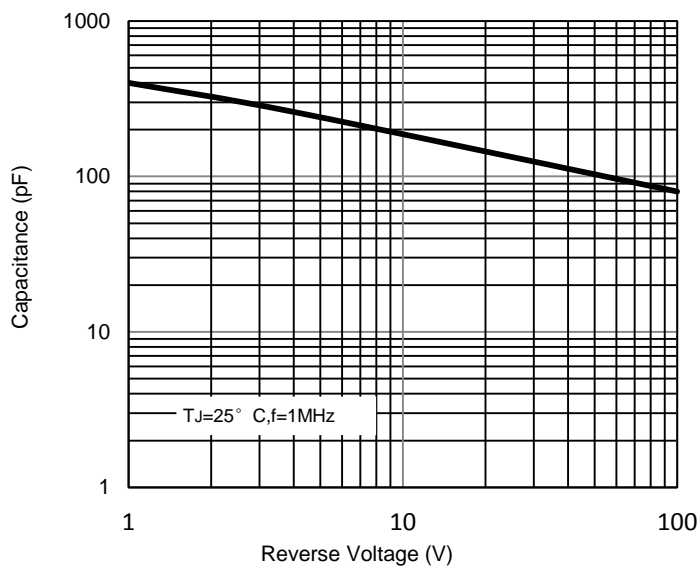

Fig. 5 - Typical Junction Capacitance



The curve above is for reference only.