

7-channel high current driver

BA6257

The BA6257 is a printer hammer solenoid driver for electronic calculators. It consists of seven circuits and is provided with a high input impedance in order to enable direct drive from MOS ICs. It features a built-in clamp diode and 16-pin DIP for easy installation.

●Applications

- Hammer solenoid drivers
- Relay drivers
- LED drivers

●Features

- 1) 7-channel Darlington transistor array.
- 2) High current driver capability of 100mA.
- 3) Can be directly connected to MOS IC devices.
- 4) High withstanding voltage of 38V for input and 24V for output.
- 5) Built-in clamp diode for driving inductive loads.

●Block diagram

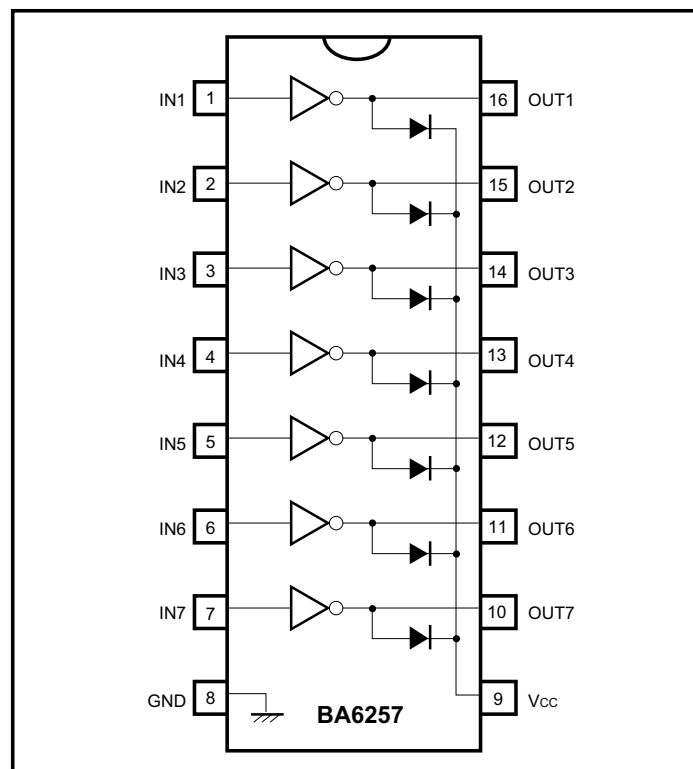

●Internal circuit configuration

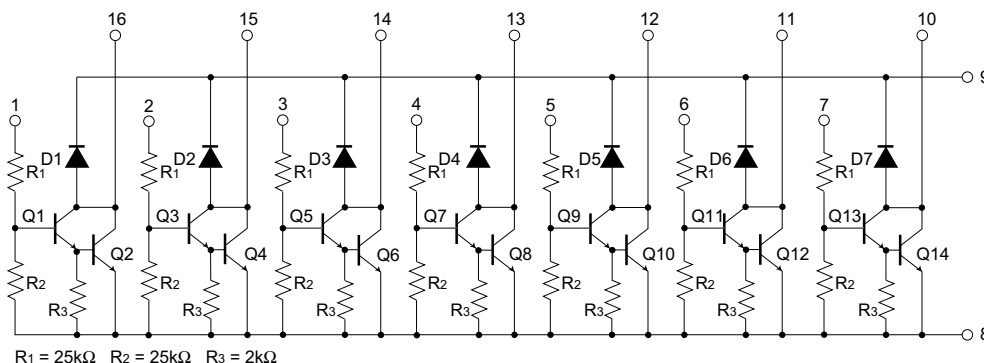

Fig.1

●Absolute maximum ratings (Ta = 25°C)

Parameter	Symbol	Limits	Unit
Power supply voltage	V _{CC}	24	V
Power dissipation	P _d	500*	mW
Operating temperature	T _{opr}	- 25 ~ + 75	°C
Storage temperature	T _{stg}	- 55 ~ + 125	°C
Collector current	I _c	100	mA
Input voltage	V _{IN}	- 0.5 ~ + 38	V

* Reduced by 5mW for each increase in Ta of 1°C over 25°C.

●Electrical characteristics (unless otherwise noted, Ta = 25°C, V_{CC} = 20V)

Parameter	Symbol	Min.	Typ.	Max.	Unit	Conditions	Measurement circuit
Usage voltage range (output)	V _{CC}	—	—	20	V	—	
Output leakage current	I _L	—	—	100	μA	V _C = 20V, V _{IN} = 0V	Fig.2
Collector saturation voltage 1	V _{CE(sat) 1}	—	1.4	2.2	V	I _{OUT} = 75mA, V _{IN} = 17V	Fig.3
Collector saturation voltage 2	V _{CE(sat) 2}	—	—	2.2	V	I _{OUT} = 75mA, V _{IN} = 8V	Fig.3
Input current	I _{IN}	—	0.6	1.4	mA	I _{OUT} = 0mA, V _{IN} = 17V	Fig.4
Diode leakage current	I _R	—	—	100	μA	V _R = 20V	Fig.5
Diode forward voltage	V _{IN}	—	1.2	—	V	I _F = 75mA	Fig.6

●Measurement circuits

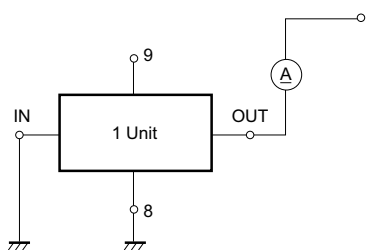

Fig.2

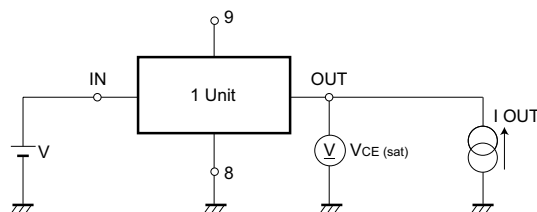

Fig.3

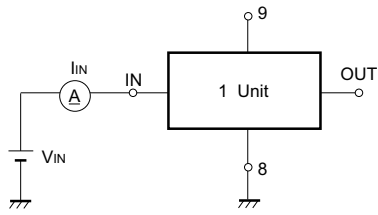

Fig.4

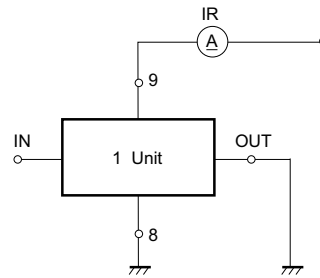

Fig.5

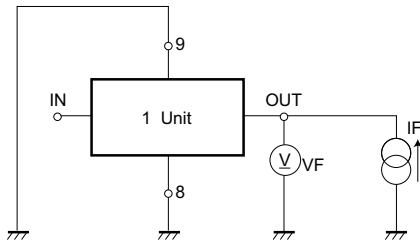

Fig.6

●Electrical characteristic curve

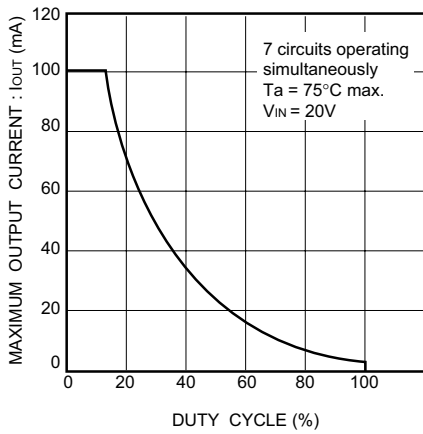

Fig.7 Output current vs. duty cycle

●External dimensions (Units: mm)

