

Three-Tone Chime
Single-Tone Chime
Dual-Tone Chime

SAB 0600
SAB 0601
SAB 0602

Features

Bipolar IC

- Melodious sound
- Few components required
- Integrated output stage for 8 Ω loudspeaker
- Standby current < 1 μA

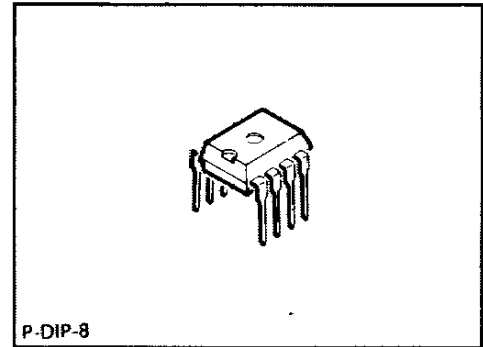

Type	Ordering Code	Package
☐ SAB 0600	Q67000-H1948	P-DIP-8
☐ ■ SAB 0601	Q67000-H2312	P-DIP-8
☐ ■ SAB 0602	Q67000-H2313	P-DIP-8

■ Not for new design

Single-Tone Chime SAB 0601 and Dual-Tone Chime SAB 0602

The two variants SAB 0601 and SAB 0602 were derived from type SAB 0600 by suppressing the last two tones or last tone, respectively, of the three-tone sequence. The SAB 0600 data applies correspondingly.

Three-Tone Chime SAB 0600

This IC generates the tone sequence of a 3-tone chime. The sound pattern is created by three harmonically tuned frequencies which are switched in succession to a summing point and decay individually in amplitude.

The tone color is adjusted by an external RC network (R_1 , C_1 , C_2). An 8 Ω loudspeaker can be connected directly via a 100 μF capacitor.

An appropriate design of the loudspeaker housing (shaped as tube or horn) enhances the volume and tone quality and contributes to a pleasant, melodious sound.

Pin Configuration

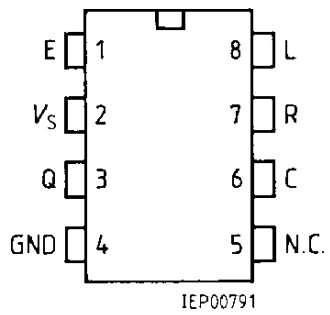

Pin Definitions and Functions

Pin	Symbol	Function
1	E	Input
2	V_s	Voltage Supply
3	Q	Output
4	GND	Ground
5	N.C.	Not connected
6	C	Oscillator
7	R	Reference
8	L	Compensation

Figure 1
Block Diagram

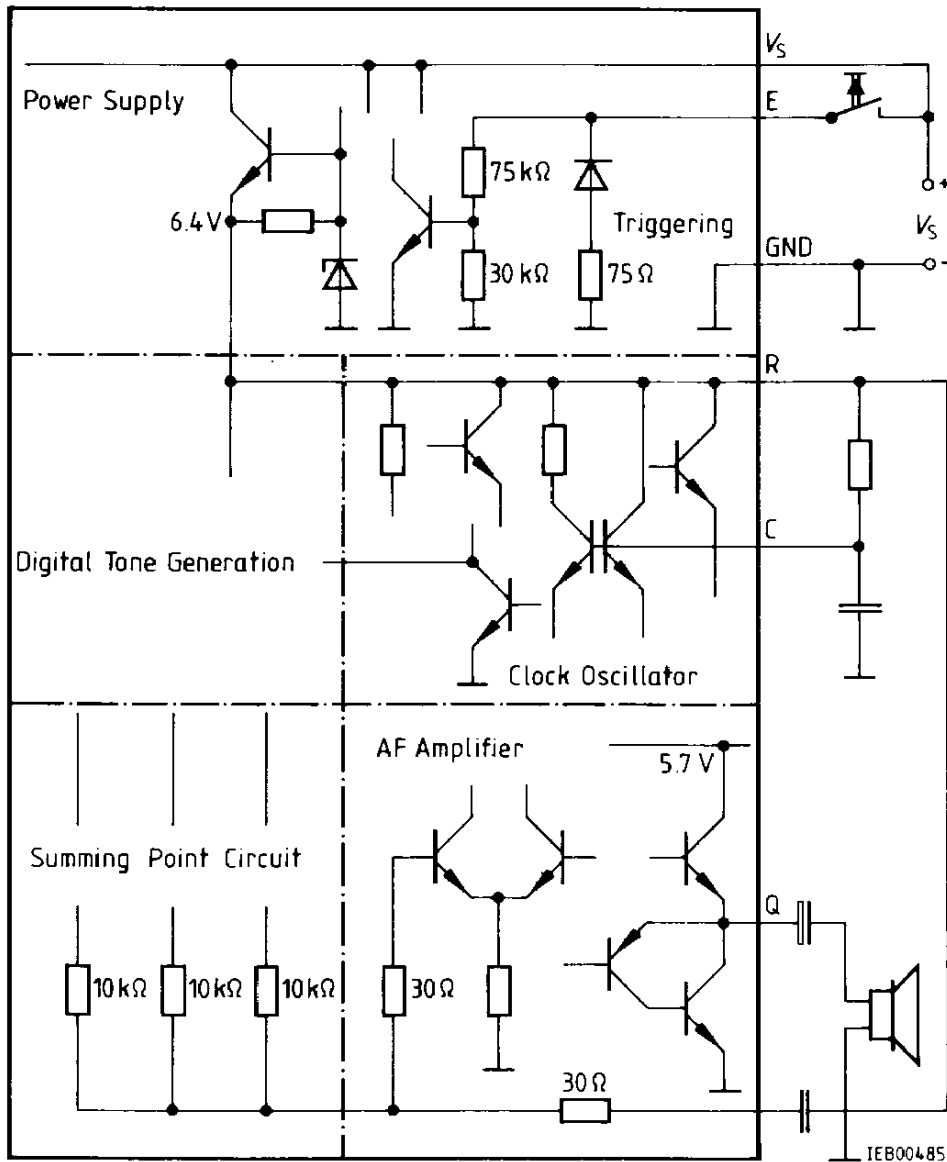

Absolute Maximum Ratings

Parameter	Symbol	Limit Values		Unit
		min.	max.	
Supply voltage	V_S	-0.5	11	V
Input voltage at E	V_E	-0.5	V_S	V
Neg. input current at E	$-I_E$		2	mA
Load resistance at Q	R_L	7		Ω
Current consumption at start of tone sequence end of tone sequence	I_{SM} I_{SO}		90 35	mA mA
Oscillator frequency at C (due to power dissipation)	f_{OSC}	6		kHz
Junction temperature	T_J		150	$^{\circ}\text{C}$
Storage temperature	T_{stg}	-55	125	$^{\circ}\text{C}$
Thermal resistance (system - air)	$R_{th SA}$		120	K/W

Operating Range

Supply voltage	V_S	7	11	V
Ambient temperature	T_A	0	70	$^{\circ}\text{C}$
Oscillator frequency at C	f_{OSC}	6	100	kHz

Characteristics

$V_S = 7\text{ V to }10\text{ V}; T_A = 25\text{ }^{\circ}\text{C}$

Parameter	Symbol	Limit Values			Unit
		min.	typ.	max.	
Standby input current	I_0		< 1	10	μA
Supply current with open output	I_{SO}		20	35	mA
Max. output power at 8 Ω (tone 3)	P_Q		0.16		W
Max. output voltage at Q (tone 3)	$V_{Q pp}$		2.8	4.0	V
Deviation of the max. individual amplitudes referred to tone 3	ΔV_{QM}		± 5		%
Frequency variation of basic oscillator with $R_1, C_1 = \text{const.}$	Δf_o		± 5		%
Triggering voltage at E	V_E	1.5		V_S	V
Input current at E ($V_E = 6\text{ V}$)	I_E	500	700		μA
Noise voltage immunity at E	$V_{EN pp}$		0.3		V
Triggering delay at $f_o = 13.2\text{ kHz}$ (t_D varies in inverse proportion to f_o)	t_D	2		5	ms
Min. value of external load resistor	R_1		10		k Ω
Max. value of external load resistor	R_1		100		k Ω

Figure 2
Test Circuit

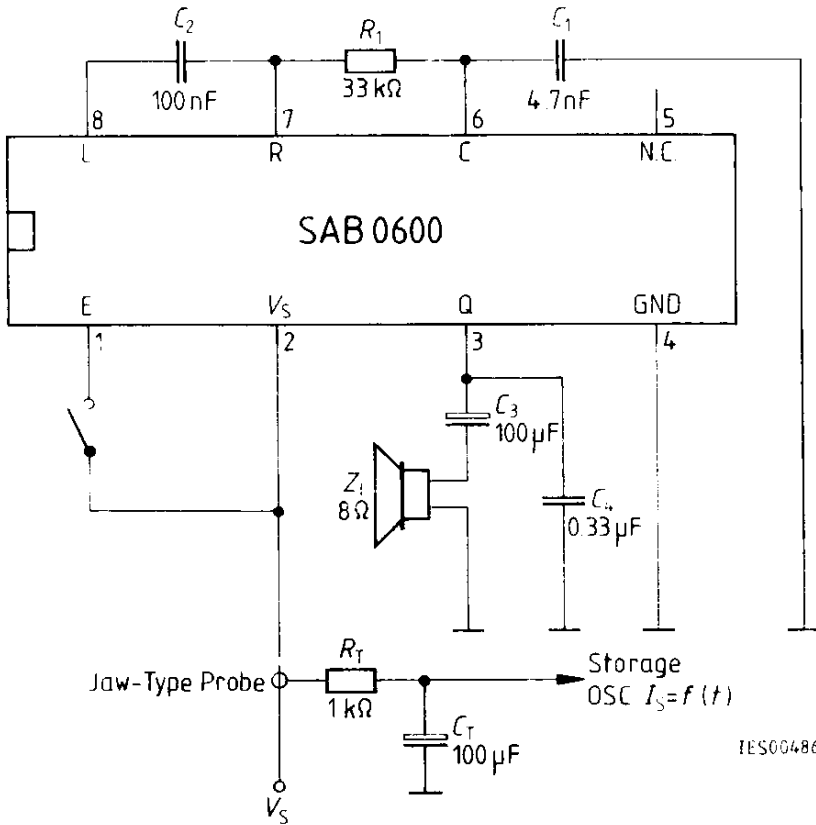

Figure 3
Integral Current Consumption in the Measurement Circuit

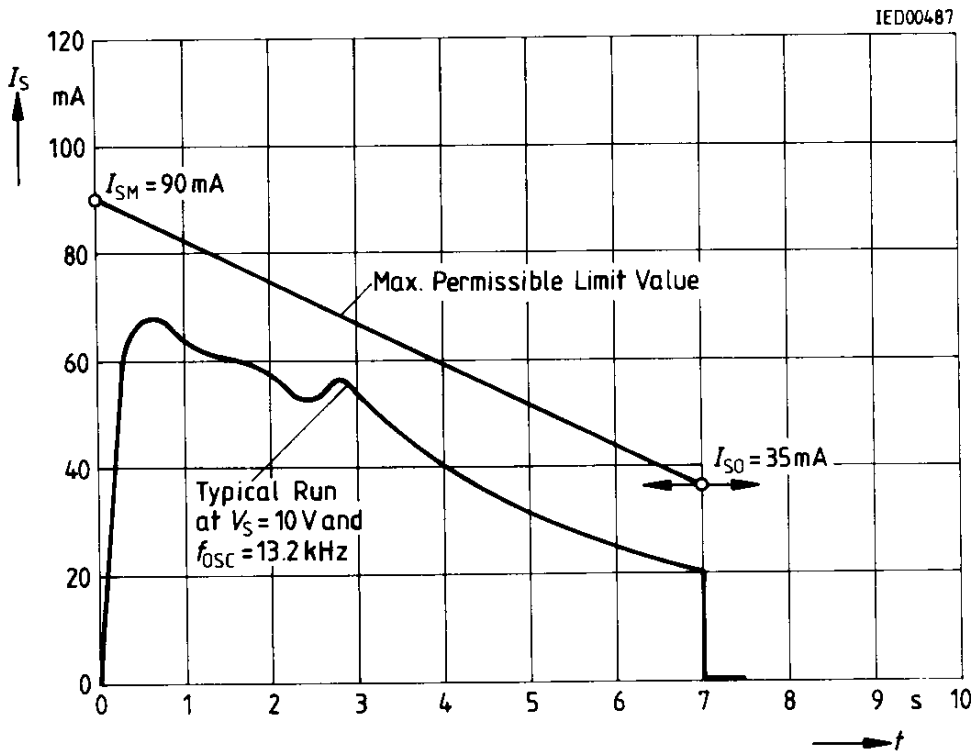
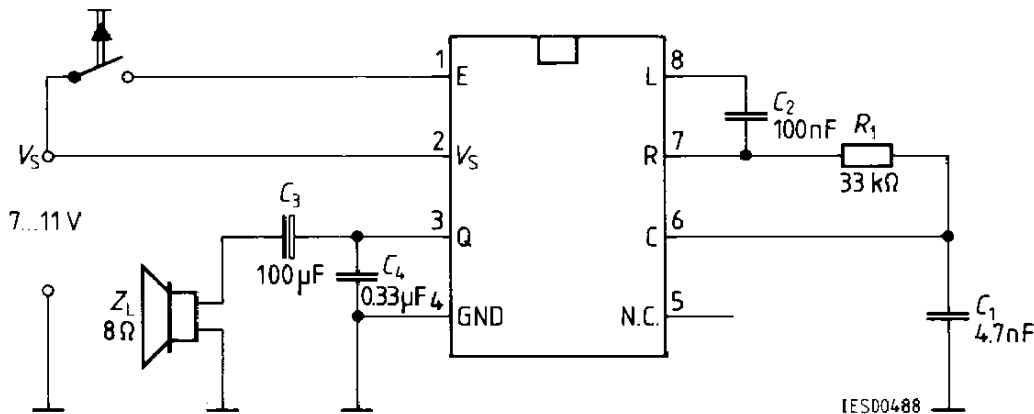

Figure 4
Typical Application Circuit



Functional Description

The three frequencies – 660 Hz, 550 Hz, and 440 Hz – are obtained by dividing the output of a 13.2 kHz oscillator. One of these three frequencies is divided again to obtain the time base for the tone-decay process. From this time base, 4-bit D/A converters (one for each tone) generate the decay voltage with which the three tones are successively activated and, overlapping each other, are attenuated. The basic frequency is determined by an external RC network (pins R and C).

The output stage can drive an 8 Ω loudspeaker with approximately 0.16 W via 100 μF. The output voltage is of square shape. To obtain a melodious output tone as required, the higher harmonics may be reduced by shunting pin L through a suitable capacitor to ground. The output volume can be regulated here by means of a potentiometer.

The circuit only draws current in the active state, and automatically switches off after the tones have decayed. The circuit is activated by a short pulse, between 1.5 V and V_S in amplitude, applied to the triggering connection E (pin 1). If the trigger voltage is still, or again, present when the tones have decayed, the three tones are repeated.

The circuit is not activated when a trigger pulse on E is shorter than 2 ms (interference suppression).

To prevent triggering of the circuit by cross-talk voltages, especially in case of long input lines, the noise voltage peaks should be limited to 0.3 V at the IC input. For this purpose the control line (possibly in front of a series resistor) can be shunted to ground through a suitable capacitor.

Application for AC and DC Triggering (Figure 5)

The input can alternatively be triggered with direct or alternating current. An internal diode circuit hereby short-circuits the input for negative halfwaves.

The peak voltage of the positive halfwave is added to the battery voltage. A series resistor must be connected into the trigger line to limit the voltage at input E (pin 1) to a maximum value equal to V_S .

The minimum input current at pin E of the SAB 0600 (pin 1) is $500 \mu\text{A}$ at 6 V. If the voltage drop occurring at $500 \mu\text{A}$ at the series resistor R_3 (Figure 5) amounts to at least the AC peak voltage between A and B (\hat{V}_{AB} AC), the IC will be safe.

The formula
$$R_{3 \min} = \frac{\hat{V}_{AB \max.}}{500 \mu\text{A}}$$

determines the lower limit for R_3 .

The upper limit for R_3 is determined by the lowest trigger voltage between A and 0 (pin 4). In the application shown in Figure 5, this will be the battery voltage if the device is also to be operated independently of the bell system (triggering by short circuit of A and B).

For reliable triggering, the SAB 0600 requires a current of at least $50 \mu\text{A}$ with approx. 1.5 V at pin E. Assuming this current, the voltage drop at R_3 must, therefore, not exceed $V_S - 1.5 \text{ V}$.

The formula
$$R_{3 \max} = \frac{V_{S \min.} - 1.5 \text{ V}}{50 \mu\text{A}}$$

results in the upper limit for R_3 .

Calculation Example for the Circuit in Figure 5

$$\max. V_{AB \text{ rms}} = 25 \text{ V} \quad \max. \hat{V}_{AB} = 25 \text{ V} \times \sqrt{2} = 35.4 \text{ V}$$

$$R_{3 \min} = \frac{35.4 \text{ V}}{500 \mu\text{A}} = 70.8 \text{ k}\Omega$$

$$\min. V_S = 6 \text{ V}$$

(The operating range of the SAB 0600 may extend to 6 V for individual components).

$$R_{3 \max} = \frac{6 \text{ V} - 1.5}{50 \mu\text{A}} = 90 \text{ k}\Omega$$

In this example, a value of $82 \text{ k}\Omega \pm 10\%$ would be suitable for R_3 .

Figure 5
Circuit for SAB 0600 Application in Home Chime Installations Utilizing
AC and DC Triggering; Adjustable Sound and Volume

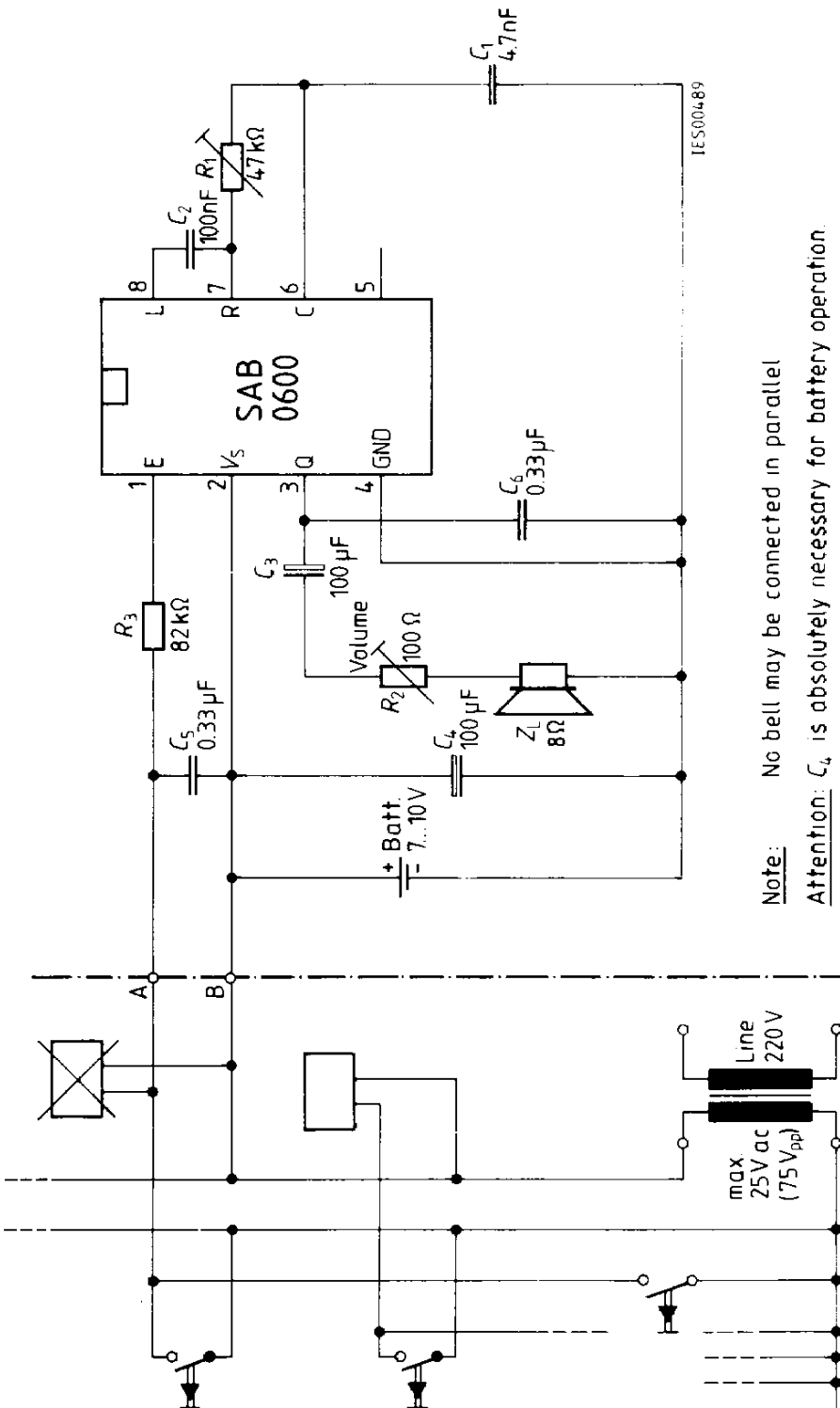

PCB layout information: Because of the peak currents at V_S , Q, and GND and to avoid RF oscillations, the lines should be designed in a flatspread way or as star pattern. Star points are the terminals of capacitor C_4 .

Further Details Regarding the Circuit in Figure 5

Since an ohmic contact between A and B causes triggering of the chime, no bell may be connected in parallel to the chime. However, paralleling several chimes does not cause any problems.

In older batteries, the higher internal resistance of the battery may cause voltage drops becoming apparent as distortions. C_4 serves as a buffer element expanding the service life of the battery.

The trigger line connected to pin A acts – in open state – as antenna for noise pulses which could trigger the chime unintentionally. Capacitor C_5 will largely suppress such interference.

If there is the risk of incorrect polarity connection when changing the battery, the battery line should be protected by a diode.

For the selection of components, the following recommendations are given:

Capacitors:

- C_1 : 4.7 nF/≥ 10 V, ± 5%; e.g. MKT
- C_2 : 100 nF/≥ 10 V, ± 20%; e.g. MKT
- C_3 : 100 μF/≥ 6.3 V, ± 100/–10%; e.g. aluminum electrolytic
- C_4 : 100 μF/≥ 10 V, + 100/–10%; e.g. aluminum electrolytic
- C_5, C_6 : 330 nF/≥ 50 V, + 100/–20%; e.g. ceramic

Resistors:

- R_3 : 82 kΩ/0.1 W, ± 10%, carbon film resistor
- R_1 : When a fixed resistor is used, 0.1 W ± 5% metal film resistor.