

# AM/FM IF Amplifier BA4220

REVISED DATA SHEET 7 7020777 0002678 4  
T-77-05-c

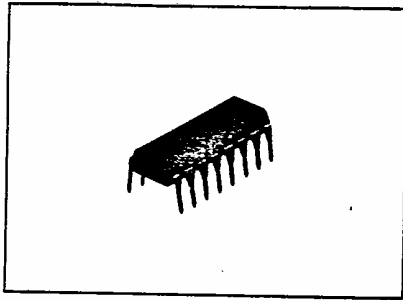

Dimensions (Unit: mm)

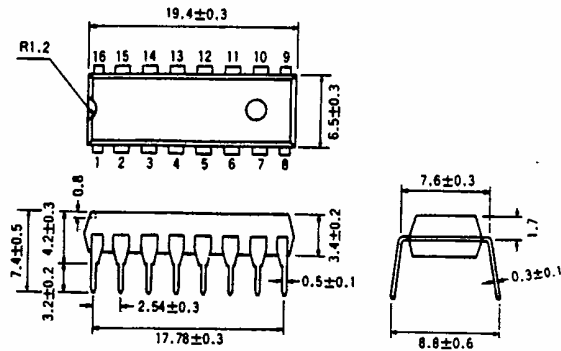

Fig. 1

The BA4220 is a monolithic integrated circuit developed for use as an AM/FM IF amplifier and detector for use in radio cassette recorders and home stereo systems. It includes an AM/FM level meter circuit and an FM tuning meter circuit, making it ideal for use as an IF system. Also, operating voltage range is wide, with stable operation at low voltages.

### Features

1. Wide operating voltage range ( $V_{cc}=3.0\sim 14.0V$ ).
2. Low current drain (typically 11.0mA for FM operation).
3. AM/FM level meter output.
4. AFC output.
5. High FM sensitivity.  
Low residual noise.  
High S/N ratio.  
Excellent AM: AGC characteristics.

### Applications

- Radio cassette recorders
- System components
- Music centers
- AM/FM radios

### Block Diagram

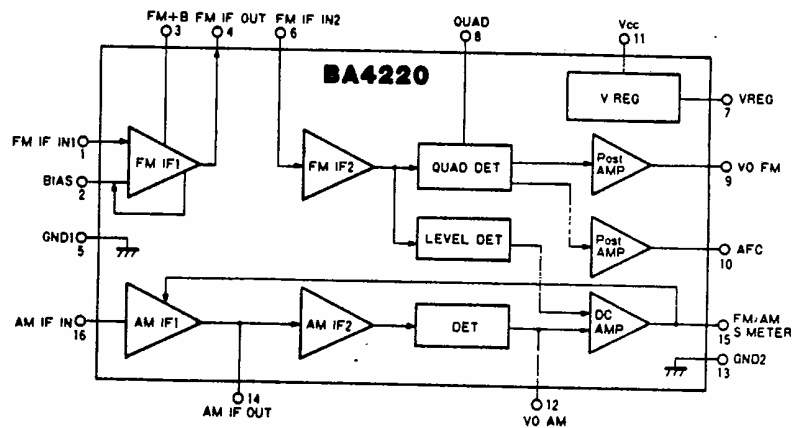

Fig. 2

### Absolute Maximum Ratings ( $T_a=25^\circ C$ )

Parameter	Symbol	Limits	Unit
Supply voltage	$V_{cc}$	16	V
Power dissipation	$P_d$	550*	mW
Operating temperature range	$T_{opr}$	-25~75	$^\circ C$
Storage temperature range	$T_{stg}$	-40~125	$^\circ C$

\* Derating is done at 5.5mW/ $^\circ C$  for operation above  $T_a=25^\circ C$

Electrical Characteristics (Ta=25°C, Vcc=6.0V)

FM: fc=10.7MHz, fm=1kHz, 100% MOD  
 AM: fc=455kHz, fm=1kHz, 30% MOD

Parameter	Symbol	Min.	Typ.	Max.	Unit	Conditions	Test circuit
Supply current	$I_o$	7.0	11	16.5	mA	—	Fig. 3
Detector output	$V_{out}$	180	250	320	mV	$V_{N1} = 100\text{dB}\mu$	Fig. 3
Total harmonic distortion	THD	—	0.3	0.9	%	$V_{N1} = 100\text{dB}\mu$	Fig. 3
Limiting sensitivity	$V_{N1}(\text{lim})$	—	33	38	dB $\mu$ V	$V_O = -3\text{dB}$	Fig. 3
Signal-to-noise ratio	S/N	72	80	—	dB	$V_{N1} = 100\text{dB}\mu$	Fig. 3
Residual noise	$V_N$	—	40	—	dB	$V_{N1} = -10\text{dB}\mu$	Fig. 3
Level meter voltage	$V_M$	—	2.4	—	V	$V_{N1} = 100\text{dB}\mu$	Fig. 3
Detector output	$V_{out}$	60	80	100	mV	$V_{N1} = 74\text{dB}\mu$	Fig. 3
Total harmonic distortion	THD	—	0.3	0.9	%	$V_{N1} = 74\text{dB}\mu$	Fig. 3
Maximum sensitivity	$S_F$	34	40	—	dB $\mu$ V	$V_{N1} = 10\text{mV}$	Fig. 3
Signal-to-noise ratio	S/N	45	55	—	dB	$V_{N1} = 74\text{dB}\mu$	Fig. 3
Level meter voltage	$V_M$	—	1.4	—	V	$V_{N1} = 100\text{dB}\mu$	Fig. 3

Test Circuit

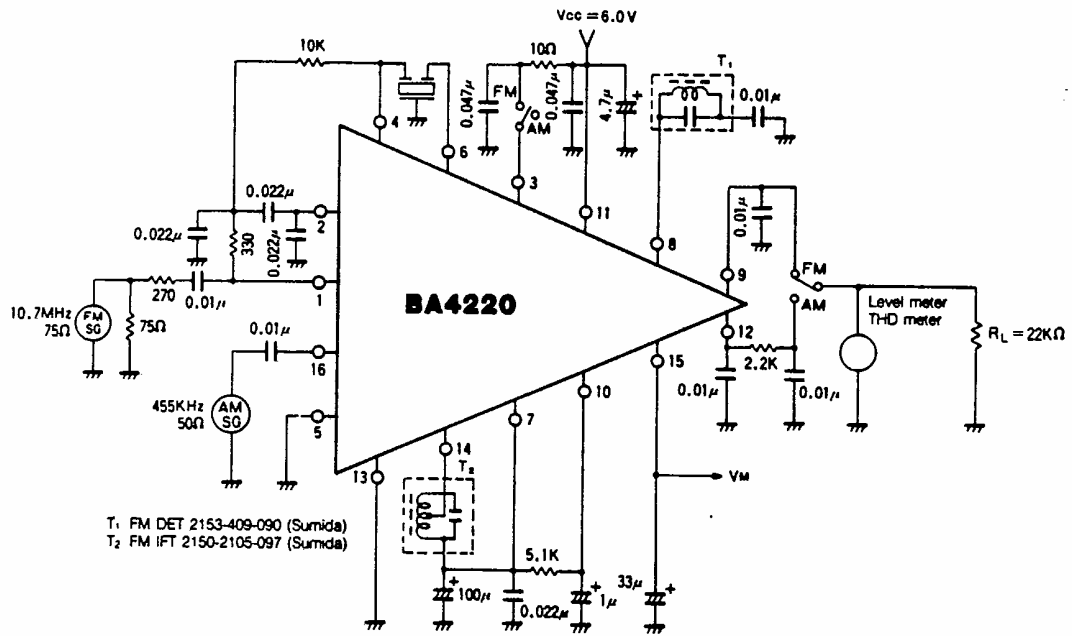

Fig. 3