

Silicon NPN Power Transistors

BU608

DESCRIPTION

- With TO-3 package
- High voltage
- Wide area of safe operation

APPLICATIONS

- For TV horizontal deflection output applications

PINNING (See Fig.2)

PIN	DESCRIPTION
1	Base
2	Emitter
3	Collector

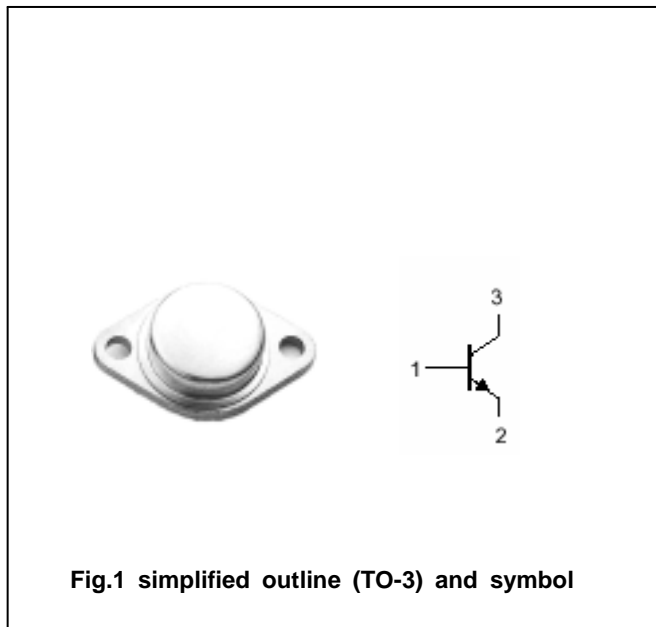

Fig.1 simplified outline (TO-3) and symbol

Absolute maximum ratings(Ta=25 )

SYMBOL	PARAMETER	CONDITIONS	VALUE	UNIT
$V_{CBO}$	Collector-base voltage	Open emitter	400	V
$V_{CEO}$	Collector-emitter voltage	Open base	200	V
$V_{EBO}$	Emitter-base voltage	Open collector	7	V
$I_C$	Collector current		7	A
$P_C$	Collector power dissipation	$T_a=25$	2.5	W
		$T_C=25$	100	
$T_j$	Junction temperature		200	
$T_{stg}$	Storage temperature		-65~200	

THERMAL CHARACTERISTICS

SYMBOL	PARAMETER	MAX	UNIT
$R_{th\ j-c}$	Thermal resistance from junction to case	1.75	/W

## Silicon NPN Power Transistors

BU608

## CHARACTERISTICS

T<sub>j</sub>=25 unless otherwise specified

SYMBOL	PARAMETER	CONDITIONS	MIN	TYP.	MAX	UNIT
V <sub>CEQ(SUS)</sub>	Collector-emitter sustaining voltage	I <sub>C</sub> =100mA ; I <sub>B</sub> =0	200			V
V <sub>(BR)CBO</sub>	Collector-base breakdown voltage	I <sub>C</sub> =1mA; I <sub>E</sub> =0	400			V
V <sub>(BR)EBO</sub>	Emitter-base breakdown voltage	I <sub>E</sub> =1mA; I <sub>C</sub> =0	7			V
V <sub>CEsat</sub>	Collector-emitter saturation voltage	I <sub>C</sub> =6A ; I <sub>B</sub> =1.2A			1.0	V
V <sub>BEsat</sub>	Base-emitter saturation voltage	I <sub>C</sub> =6A ; I <sub>B</sub> =1.2A			1.5	V
I <sub>CBO</sub>	Collector cut-off current	V <sub>CB</sub> =400V; I <sub>E</sub> =0			10	μ A
I <sub>EBO</sub>	Emitter cut-off current	V <sub>EB</sub> =5V; I <sub>C</sub> =0			10	μ A
h <sub>FE-1</sub>	DC current gain	I <sub>C</sub> =1A ; V <sub>CE</sub> =5V	15			
h <sub>FE-2</sub>	DC current gain	I <sub>C</sub> =7A ; V <sub>CE</sub> =5V	5			

PACKAGE OUTLINE

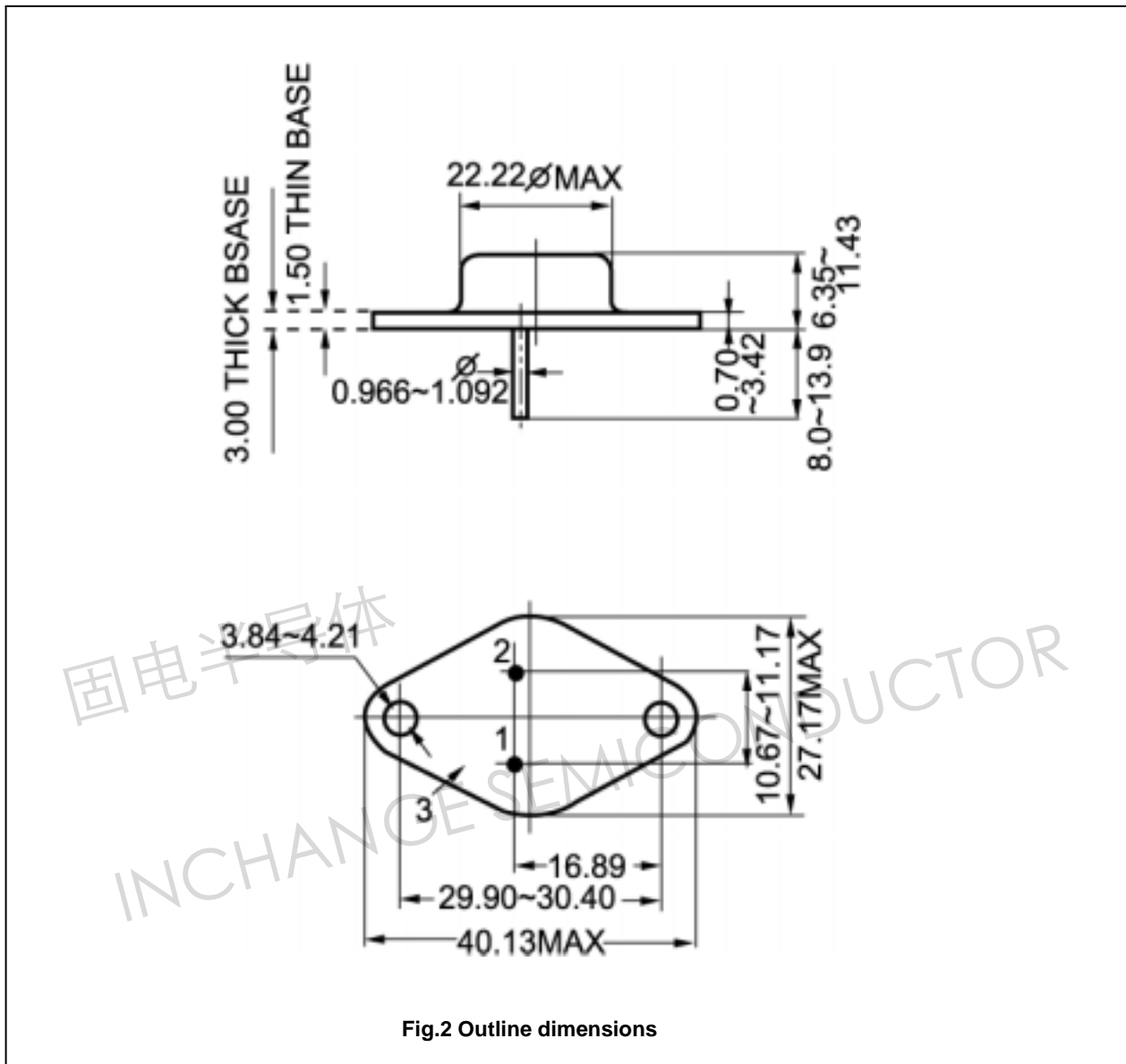

Fig.2 Outline dimensions