

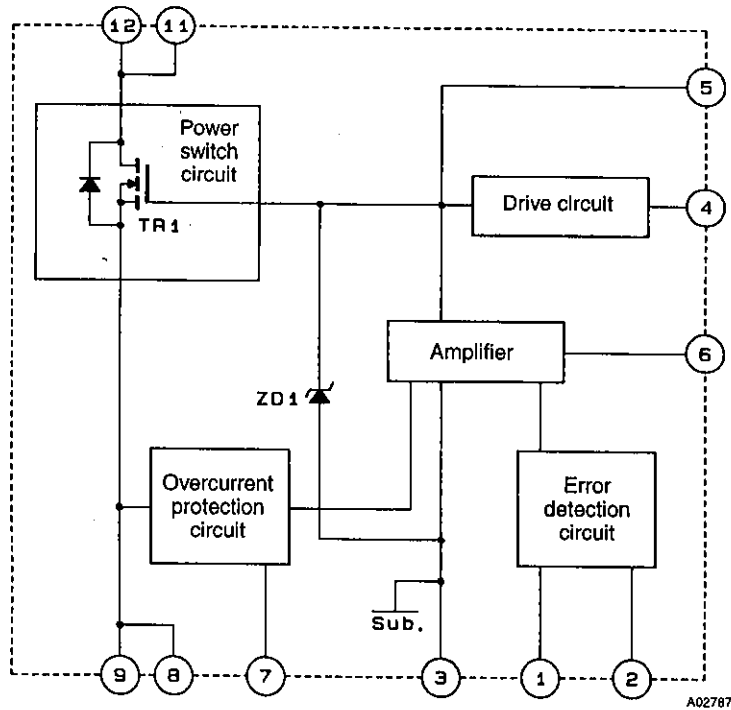

## Block Diagram



The back surface of the IC is not an insulator, and is effectively at pin 3 potential.

## Pin Functions

Number	Function
1	$V_{rel}$ (40.5V typ) input
2	Error detection level
3	Ground
4	Drive voltage input
5	TR1 gate
6	Amplifier circuit control
7	OCP setting level input
8	TR1 source
9	
11	TR1 drain
12	

## Specifications

**Maximum Ratings** at  $T_a = 25^\circ\text{C}$ ,  $T_c = 25^\circ\text{C}$  unless otherwise specified

Parameter	Symbol	Conditions	Ratings	Unit
Operating substrate temperature	$T_c \text{ max}$	Recommended value is $105^\circ\text{C}$ .	115	$^\circ\text{C}$
AC input voltage	$V_{AC}$	Specified test circuit	280	Vrms
Operating temperature	$T_{opg}$		-10 to +85	$^\circ\text{C}$
Storage temperature	$T_{stg}$		-30 to +115	$^\circ\text{C}$
Maximum output power	$W_o \text{ max}$	Specified test circuit, $V_o = 135\text{V}$	110	W

STK730-060

Parameter	Symbol	Conditions	Ratings	Unit
<b>[TR1]</b>				
Drain current	$I_D$	Refer to ASO characteristics for overcurrent condition.	3	A
Pulse drain current	$I_{D(pulse)}$		7	A
Drain reverse current	$I_{DR}$		3	A
Gate-source voltage	$V_{GSS}$		$\pm 30$	V
Allowable power dissipation	$P_D$		78.1	W
Chip junction temperature	$T_j \text{ max}$		150	$^{\circ}\text{C}$
Thermal resistance	$\theta_{j-c}$		1.6	$^{\circ}\text{C/W}$
<b>[ZD1]</b>				
Allowable power dissipation	$P_{ZD1}$		500	mW
Chip junction temperature	$T_j(\text{ZD1}) \text{ max}$		125	$^{\circ}\text{C}$
Thermal resistance	$\theta_{j-c}(\text{ZD1})$		0.2	$^{\circ}\text{C/mW}$

**Allowable Operating Ranges** at  $T_a = 25^{\circ}\text{C}$

Parameter	Symbol	Conditions	Ratings	Unit
Pin 4 input voltage	$V_4$		$\pm 8$ to $\pm 24$	V
Oscillator frequency	$f_{osc}$		20 to 120	kHz

**Operating Characteristics** at  $T_a = 25^{\circ}\text{C}$ ,  $T_c = 25^{\circ}\text{C}$  unless otherwise specified, specified test circuit

Parameter	Symbol	Conditions	min	typ	max	Unit
Output voltage setting		$I_{IN} = 8\text{mA}$	40.0	40.5	41.0	V
Output voltage temperature coefficient		$T_c = 0$ to $105^{\circ}\text{C}$ , $I_{IN} = 8\text{mA}$	-	7	-	$\text{mV}/^{\circ}\text{C}$
<b>[TR1]</b>						
Drain-source breakdown voltage	$V_{(BR)DSS}$	$I_D = 10\text{mA}$ , $V_{GS} = 0\text{V}$	900	-	-	V
Gate-source cutoff voltage	$V_{GS(off)}$	$I_D = 1\text{mA}$ , $V_{DS} = 10\text{V}$	2.0	-	3.0	V
ON resistance	$R_{DS(on)}$	$I_D = 1.5\text{A}$ , $V_{GS} = 10\text{V}$	-	5.0	7.0	$\Omega$
Input capacitance	$C_{iss}$	$V_{DS} = 10\text{V}$ , $V_{GS} = 0\text{V}$ , $f = 1\text{MHz}$	-	500	-	$\mu\text{F}$
<b>[ZD1]</b>						
Zener voltage	$V_Z$	$I_Z = 5\text{mA}$	23.7	-	26.3	V

Circuit Function Diagram

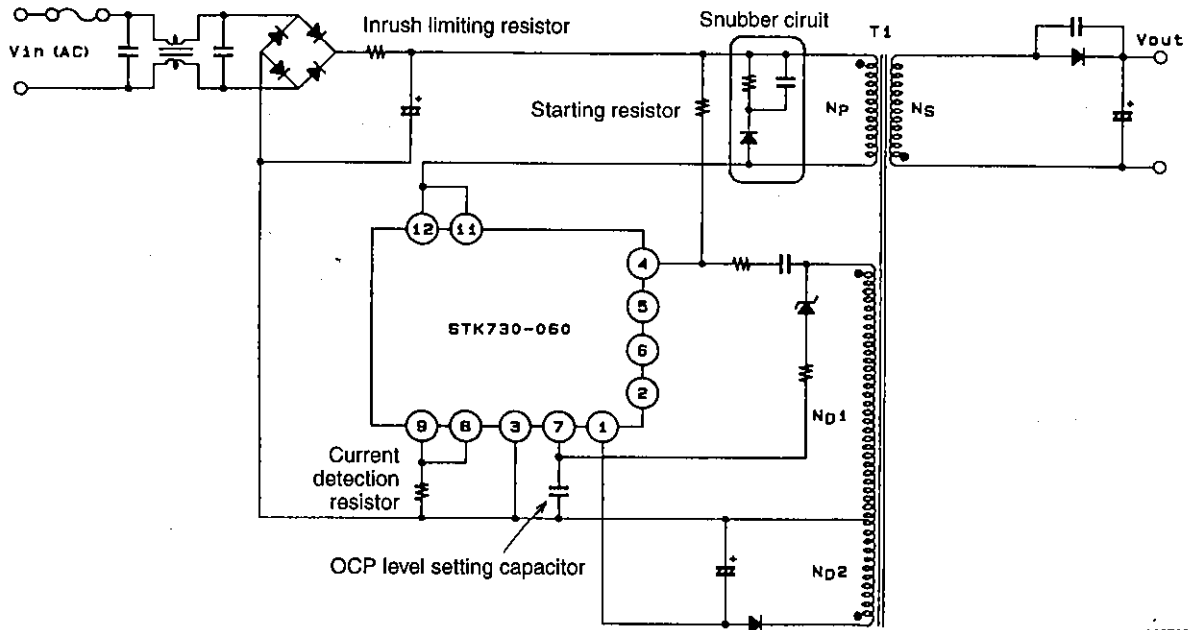

A02766

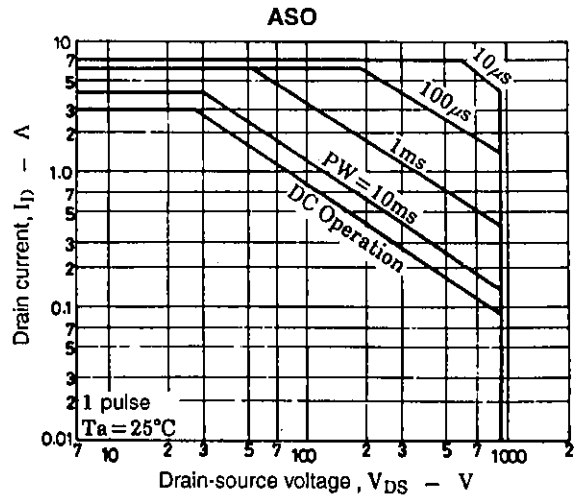
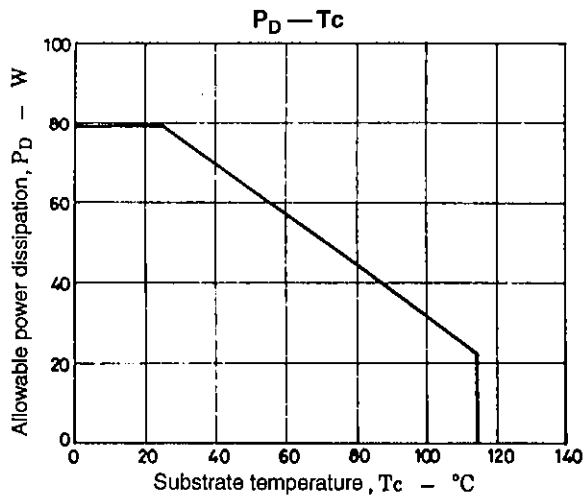

Sample Application Circuit (200V System)

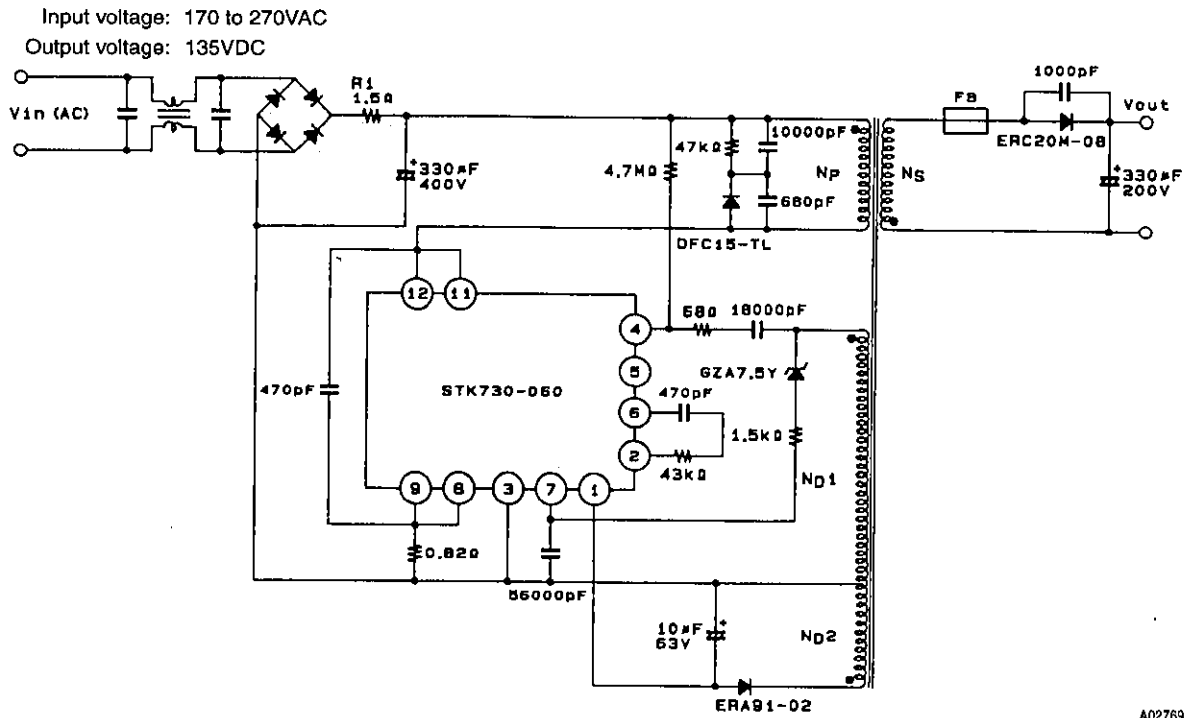

Pulse Transformer Specifications

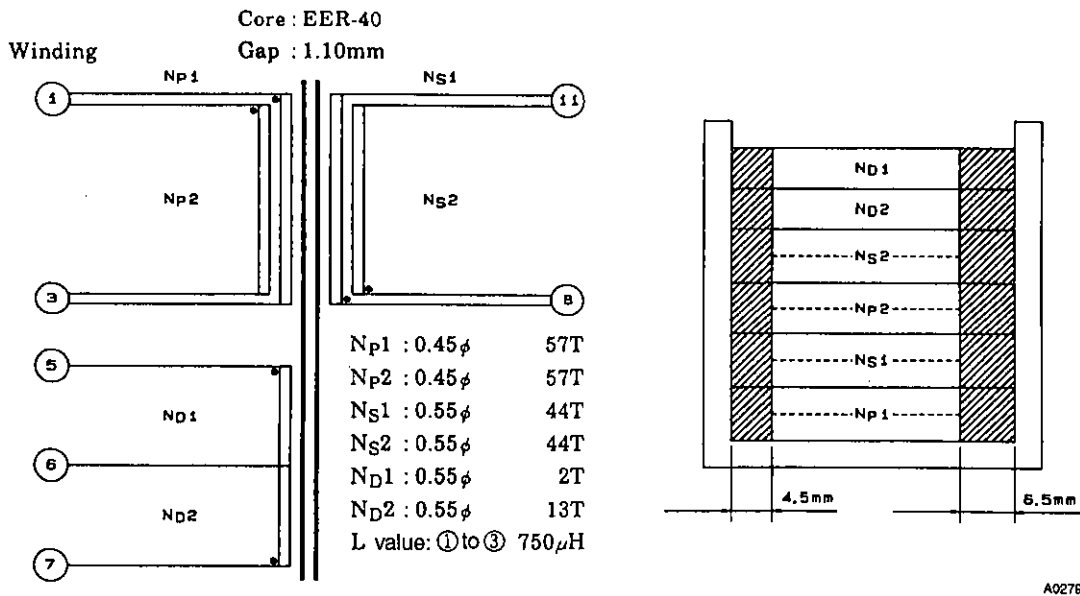

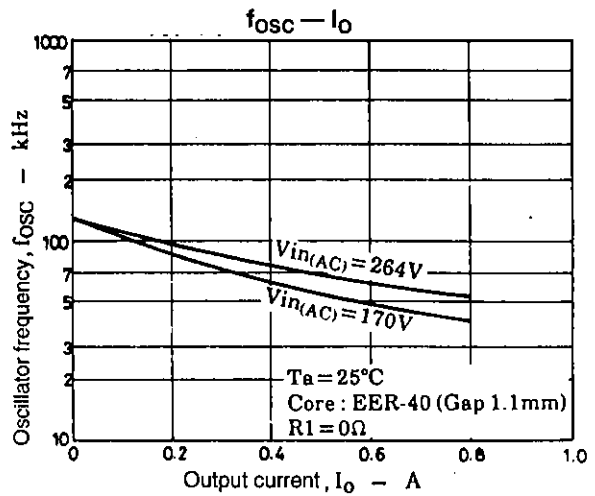
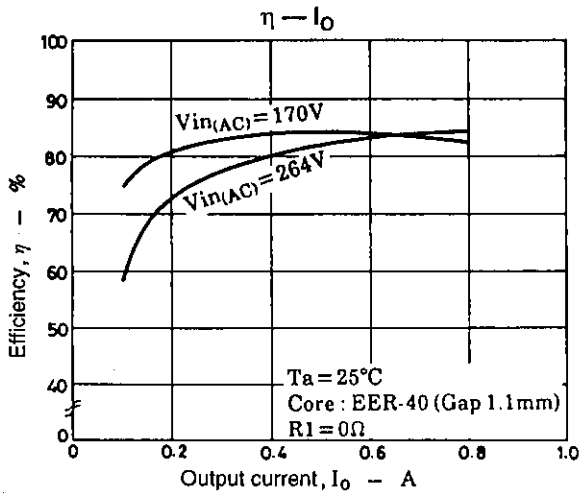
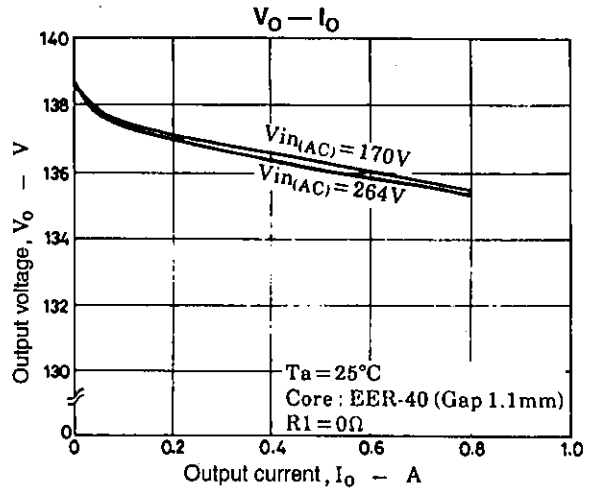
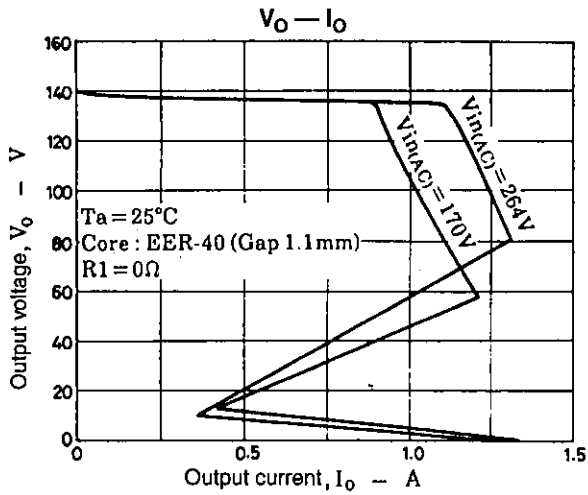

Sample Application Circuit (World Input System)

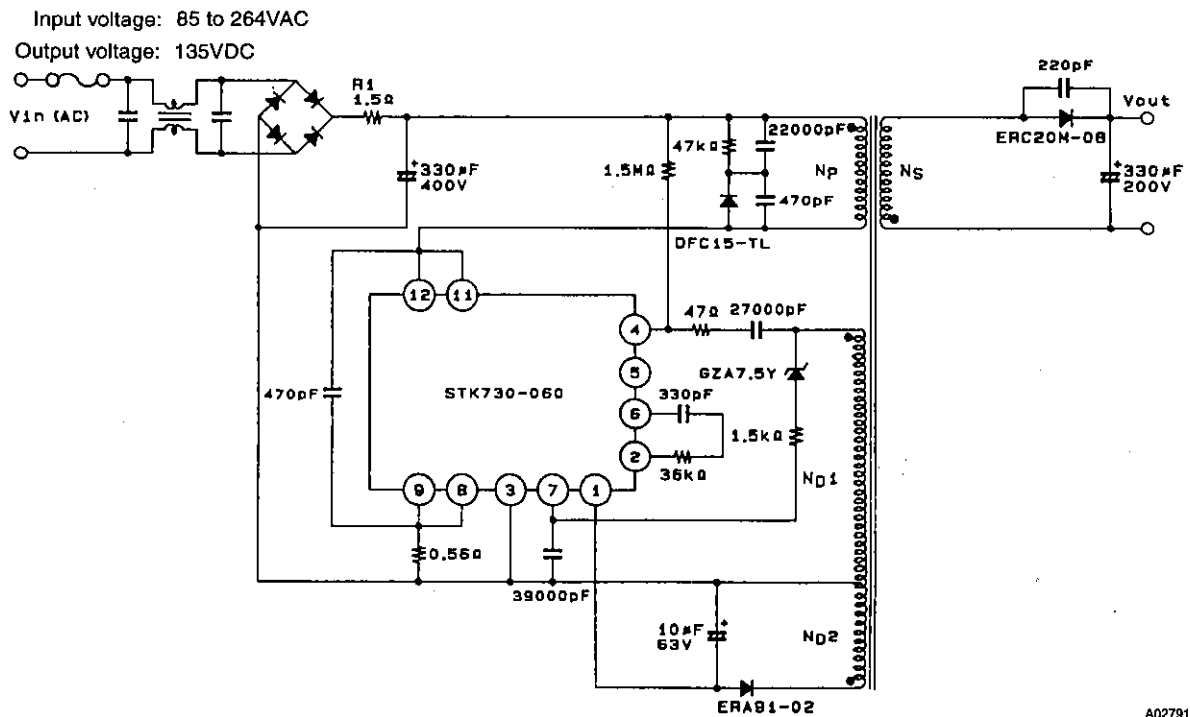

A02791

Pulse Transformer Specifications

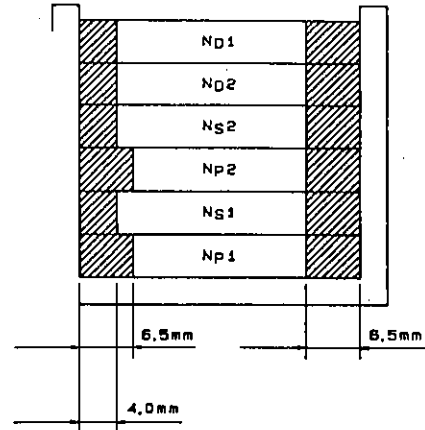
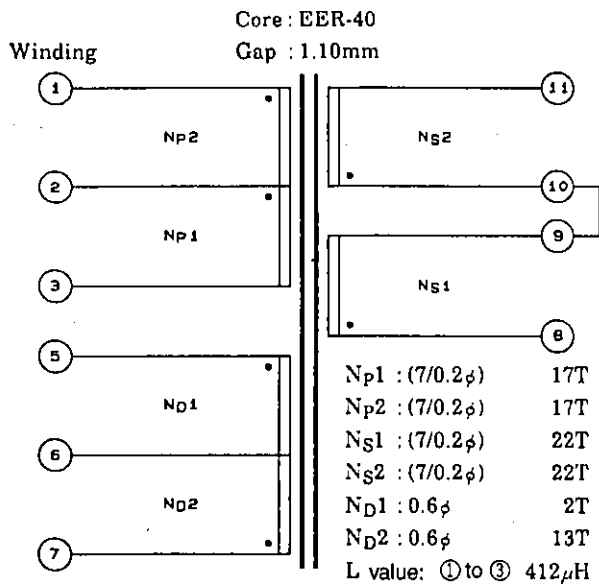

A02792

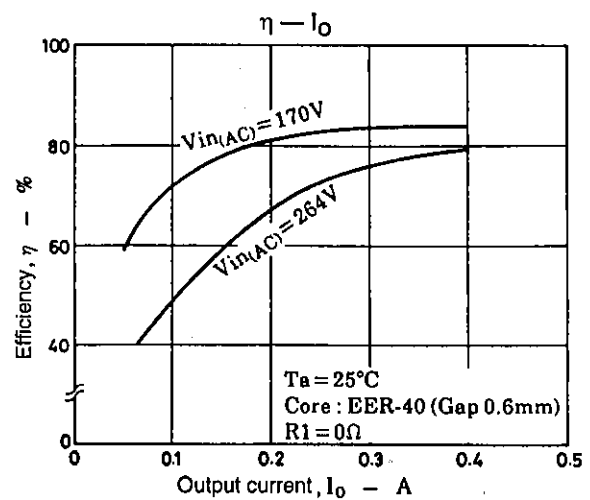
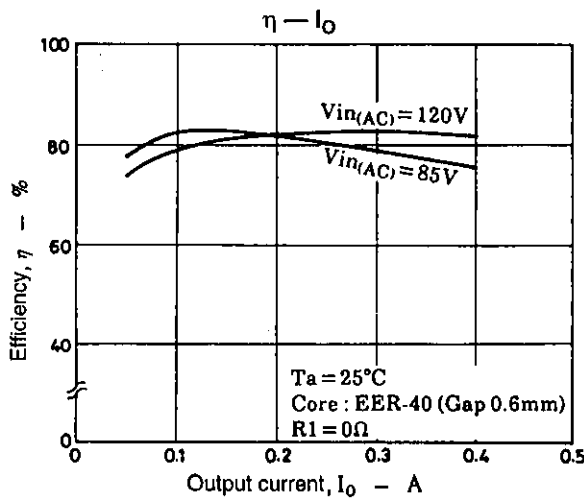
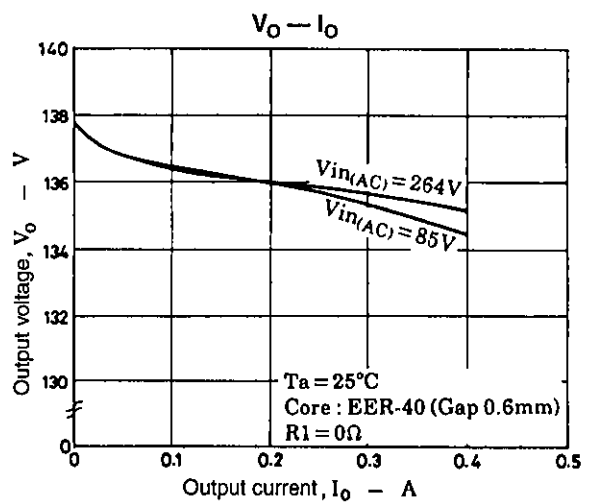
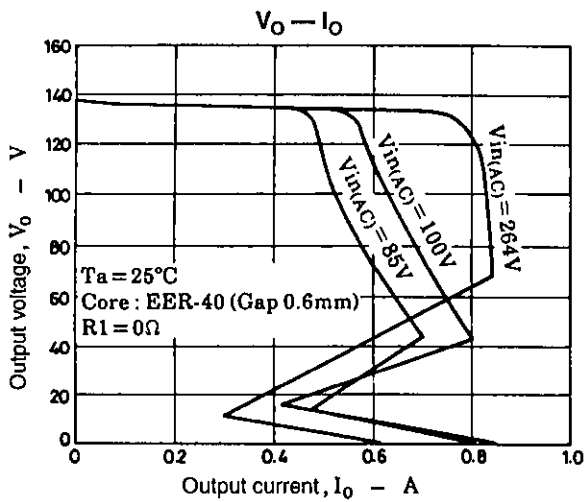

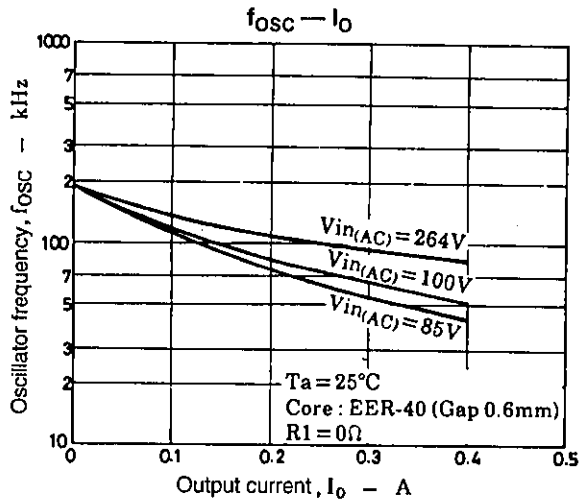

### Series Organization

These devices form a series with varying output power ratings.

Device	Maximum ratings				Operating characteristics			
	V <sub>DSS</sub> [V]	T <sub>stg</sub> [°C]	T <sub>c max</sub> [°C]	T <sub>j max</sub> [°C]	I <sub>o</sub> [A]	Input voltage [V]	Output power [W]	ON resistance [Ω]
STK730-010	500	-30 to +115	+115	+150	6.0	85 to 132	110	1.4
STK730-020					8.0		145	0.8
STK730-030					10.0		180	0.7
STK730-040					12.0		210	0.55
STK730-050					15.0		280	0.3
STK730-060	900				3.0	170 to 264	110	5.0
STK730-070					5.0		180	3.0
STK730-080					6.0		210	2.0
STK730-090					8.0		280	1.2