

Silicon NPN Power Transistors

2SD1413

DESCRIPTION

- With TO-220Fa package
- High DC current gain
- Low saturation voltage
- Complement to type 2SB1023
- DARLINGTON

APPLICATIONS

- Power amplifier and switching applications
- Hammer drive,pulse motor drive applications

PINNING

| PIN | DESCRIPTION |
|-----|-------------|
| 1 | Base |
| 2 | Collector |
| 3 | Emitter |

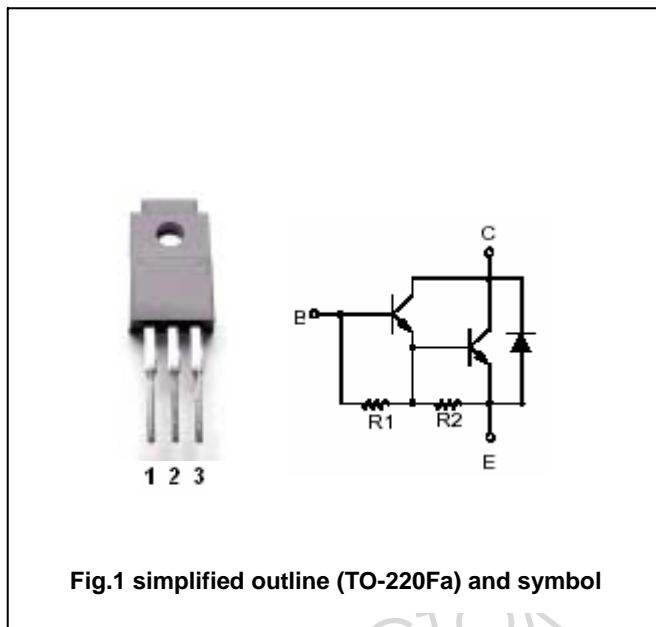

Fig.1 simplified outline (TO-220Fa) and symbol

Absolute maximum ratings(Ta=25)

| SYMBOL | PARAMETER | CONDITIONS | VALUE | UNIT |
|------------------|-----------------------------|--------------------|---------|------|
| V _{CBO} | Collector-base voltage | Open emitter | 60 | V |
| V _{CEO} | Collector -emitter voltage | Open base | 40 | V |
| V _{EBO} | Emitter-base voltage | Open collector | 5 | V |
| I _C | Collector current | | 3 | A |
| I _B | Base current | | 0.5 | A |
| P _C | Collector power dissipation | T _C =25 | 20 | W |
| T _j | Junction temperature | | 150 | |
| T _{stg} | Storage temperature | | -55~150 | |

Silicon NPN Power Transistors

2SD1413

CHARACTERISTICS

T_j=25 unless otherwise specified

| SYMBOL | PARAMETER | CONDITIONS | MIN | TYP. | MAX | UNIT |
|----------------------|--------------------------------------|--|------|------|-----|------|
| V _{(BR)CEO} | Collector-emitter breakdown voltage | I _C =25mA; I _B =0 | 40 | | | V |
| V _{CEsat} | Collector-emitter saturation voltage | I _C =2A ; I _B =4mA | | | 1.5 | V |
| V _{BEsat} | Base-emitter saturation voltage | I _C =2A ; I _B =4mA | | | 2.0 | V |
| I _{CBO} | Collector cut-off current | V _{CB} =60V; I _E =0 | | | 20 | μ A |
| I _{EBO} | Emitter cut-off current | V _{EB} =5V; I _C =0 | | | 2.5 | mA |
| h _{FE-1} | DC current gain | I _C =1A ; V _{CE} =2V | 2000 | | | |
| h _{FE-2} | DC current gain | I _C =3A ; V _{CE} =2V | 1000 | | | |

Switching times

| | | | | | | |
|------------------|--------------|---|--|-----|--|-----|
| t _{on} | Turn-on time | I _{B1} =-I _{B2} =6mA V _{CC} =30V , R _L =10 | | 0.1 | | μ s |
| t _{stg} | Storage time | | | 1.0 | | μ s |
| t _f | Fall time | | | 0.2 | | μ s |

PACKAGE OUTLINE

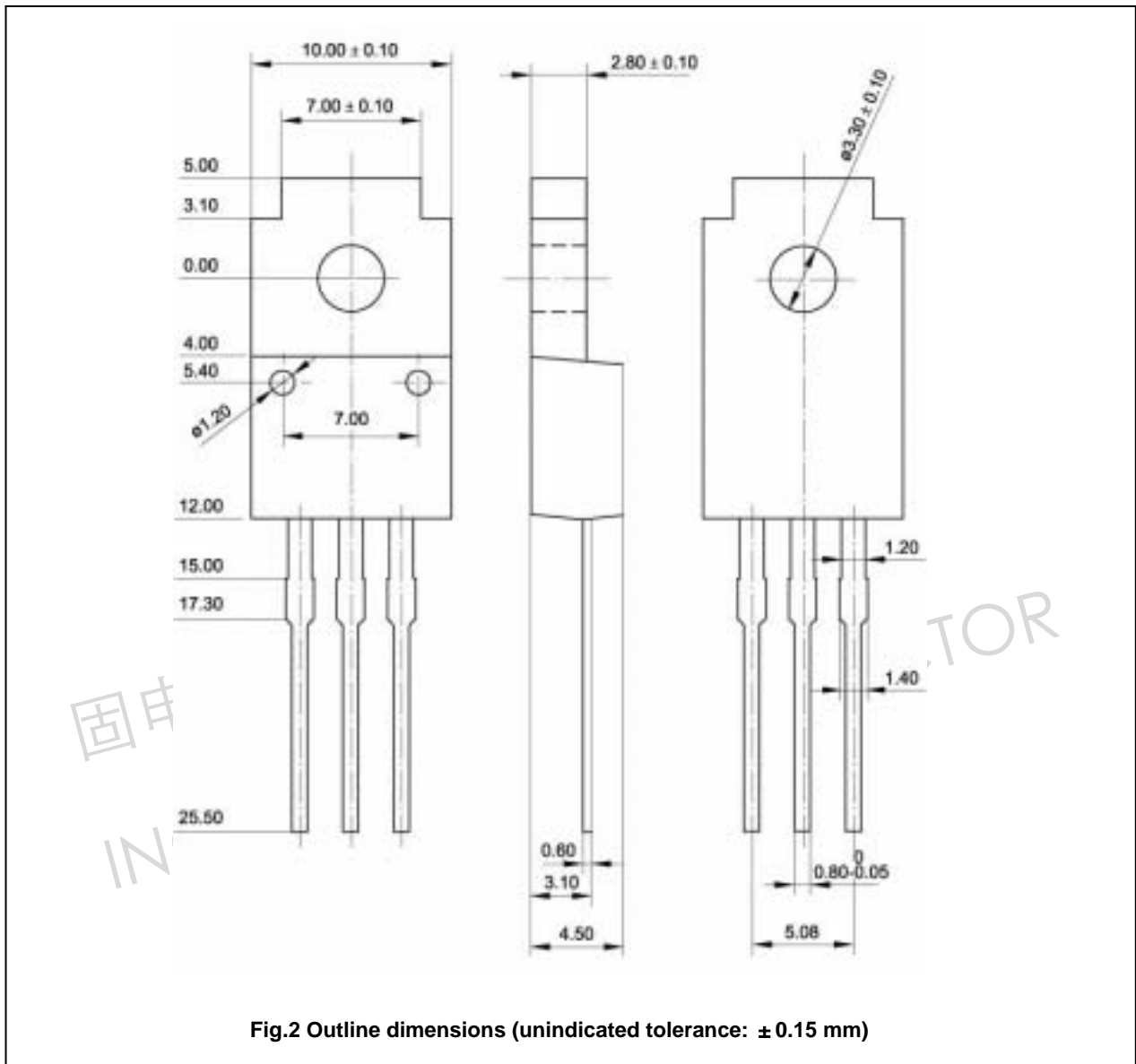

Fig.2 Outline dimensions (unindicated tolerance: ± 0.15 mm)