

TOSHIBA Bipolar Linear Integrated Circuit Silicon Monolithic

## TA8132AN,TA8132AF,TA2012N,TA2012F

3V AM / FM IF + MPX  
(For Digital Tuning System)

TA8132AN, TA8132AF and TA2012N, TA2012F are the AM / FM IF+ST DET system ICs, which are designed for DTS radios. These are included many functions and these can be used for digital tuning system with IF counter.

### Features

- Built-in AM / FM IF and FM stereo PLL multiplex decoder.
- Suitable for combination with digital tuning system which is included IF counter.
  - One terminal type AM / FM IF count output (auto stop signal) for IF counter of digital tuning system.
    - FM: 10.7MHz or 1.3375MHz (1 / 8 dividing)  
changeable by external switch
    - AM: 450kHz
  - Built-in mute circuit for IF count output. It is controlled by the IF request signal from digital tuning system,
    - Pin(8) level: High → come out  
Low → non output
  - Adjustable for IF count output sensitivity by external resistance of pin(2).
- For adopting ceramic discriminator and ceramic resonator, it is not necessary to adjust the FM quad detector circuit and FM ST DET VCO circuit.
- S curve characteristics of FM detection output in TA8132AN, TA8132AF and TA2012N, TA2012F are reverse to each other.
  - TA8132AN, TA8132AF: Reverse characteristic.
  - TA2012N, TA2012F: Normal characteristic.
- Built-in one terminal type AM low cut circuit.
- TA2053F is reverse pin type of TA2012F.
- Operating supply voltage range (Ta = 25°C)  
VCC (opr.) = 1.8~8.0V

TA8132AN  
TA2012N

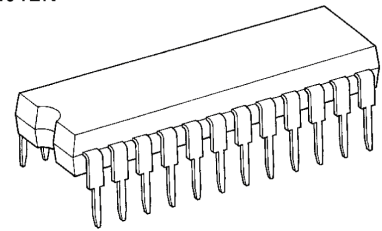

SDIP24-P-300-1.78

TA8132AF  
TA2012F

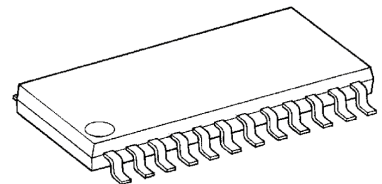

SSOP24-P-300-1.00

### Weight

SDIP24-P-300-1.78: 1.2g (typ.)  
SSOP24-P-300-1.00 : 0.31g (typ.)

## Block Diagram

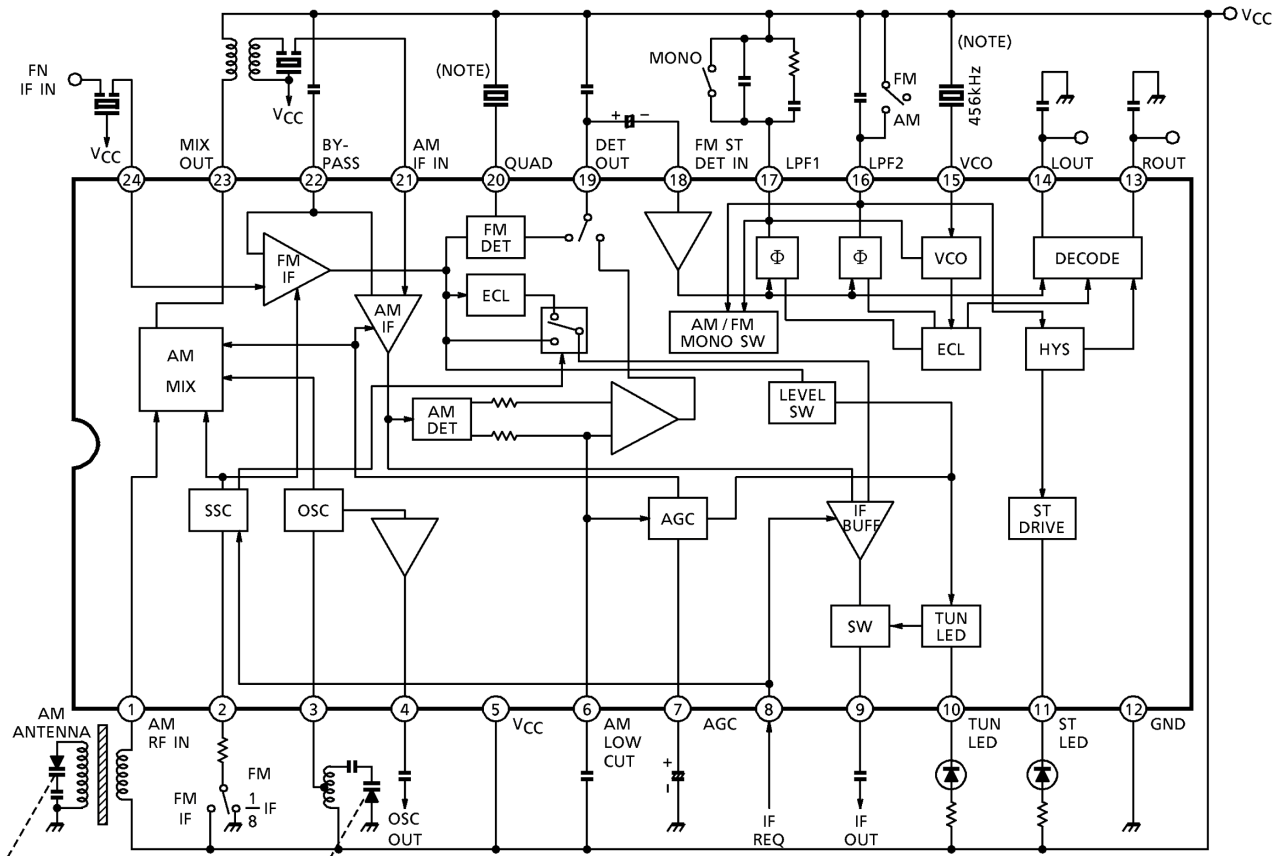

(Note)

We recommend

Ceramic resonator: CSB456F18

Ceramic discriminator: CDA10.7MG18 (MURATA MFG CO., LTD)

## Explanation Of Terminals

Pin No.	Item	Internal Circuit	DC Voltage (V) (at no Signal)	
			AM	FM
1	AM RF IN		3.0	3.0
2	<ul style="list-style-type: none"> <li>• IF count output sensitivity adjust terminal</li> <li>• FM IF divider control terminal</li> </ul>		—	—
3	AM OSC		3.0	3.0
4	AM OSC OUT		2.7	3.0
5	V <sub>CC</sub>	—	3.0	3.0
6	AM LOW CUT		2.3	2.3

Pin No.	Item	Internal Circuit	DC Voltage (V) (at no Signal)	
			AM	FM
7	AGC		0.25	0.35
8	IF OUT SW		—	—
9	IF OUT		3.0	3.0
10	TUN LED (tuning LED)		—	—
11	ST LED (stereo LED)		—	—
12	GND	—	0	0
13 14	R-OUT L-OUT		1.0	1.0

Pin No.	Item	Internal Circuit	DC Voltage (V) (at no Signal)	
			AM	FM
15	VCO		2.5	2.5 (VCO stop mode)
16	LPF2 • LPF terminal for synchronous detector • Bias terminal for AM / FM switch circuit $V_{16} = V_{CC} \rightarrow \text{AM}$ $V_{16} = \text{open} \rightarrow \text{FM}$		3.0	2.2
17	LPF1 • LPF Terminal for phase detector • VCO stop terminal $V_{17} = V_{CC} \rightarrow \text{VCO stop}$		2.7	2.2
18	FM ST DET IN		0.7	0.7
19	DET OUT		1.1	1.1

Pin No.	Item	Internal Circuit	DC Voltage (V) (at no Signal)	
			AM	FM
20	QUAD (FM QUAD. Detector)		2.4	2.1
21	AM IF IN		3.0	3.0
22	BY-PASS By-pass for AM/FM IF AMP		2.3	2.8
23	AM MIX OUT		3.0	3.0
24	FM IF IN		3.0	3.0

## Application Note

### 1. How to control the IF count output signal (pin(9) output)

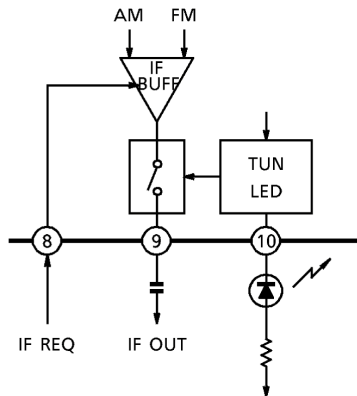

		TUN LED	
		ON	OFF
V <sub>8</sub>	H	Come out	Non output
	L	Non output	Non output

- Whether or not there is the IF count output signal (pin(9) output) is determined by the and of the pin(8) control voltage: V<sub>8</sub> and tuning LED on / off switching.

In the condition of

V<sub>8</sub>: High (active high, V<sub>TH</sub> = 0.8V (typ.))

TUN LED: ON (V<sub>in</sub> ≥ V<sub>L</sub>+2dBμV EMF (typ.))

the IF count output signal comes out from the pin(9).

In the case of the tuning LED function is not needed, it doesn't matter the pin(10) is opened.

- The output impedance of pin(9) is 1.5kΩ (typ.) (cf.P.4)  
It is possible to reduce the IF count output signal level to add the resistance between the pin(9) and the VCC line.
- The signal waveform is the rectangular wave, and the level is 500mV<sub>p-p</sub> (typ.)

### 2. How to control the divider of FM IF

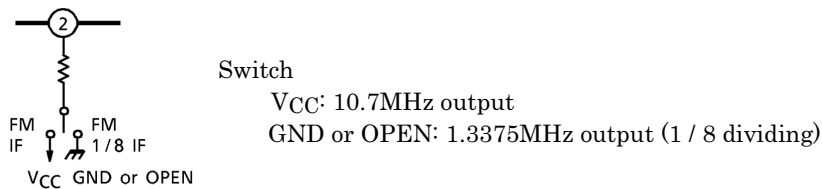

### 3. How to adjust the IF count output sensitivity

- The IF count output sensitivity (search sensitivity)  
Can be adjusted by varying the IF AMP gain for FM and varying the MIXER gain for AM. This setting is made by changing the value of external resistance R<sub>2</sub> which is connected to pin(2).
- However, this is only possible at the auto-tuning mode. (external voltage supplied to pin(8) is at high level.)  
The original again returns while receiving a broadcast station (supplied voltage to pin(8) is at low level.)

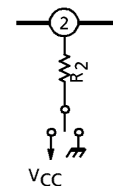

- The gain loss of FM IF AMP

		R <sub>2</sub>	
		0Ω	10KΩ (Note)
Mode	IF (10.7MHz)	-20dB	-1dB
	1 / 8 IF (1.3375MHz)	-20dB	-1dB

(Note)

- In the condition of the 1 / 8 IF mode, it is possible to set up R<sub>2</sub> = ∞ (OPEN).
- In the condition of IF mode, it is necessary to set up the value of R<sub>2</sub> under 10kΩ. When the R<sub>2</sub> is over 10kΩ it is feared that the mode is change to the 1 / 8 IF mode.

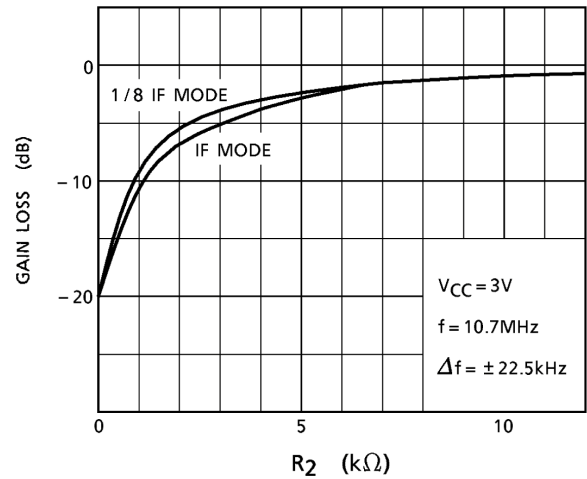

- The gain loss of AM MIXER

R <sub>2</sub>	
0Ω	10KΩ
-16dB	-1dB

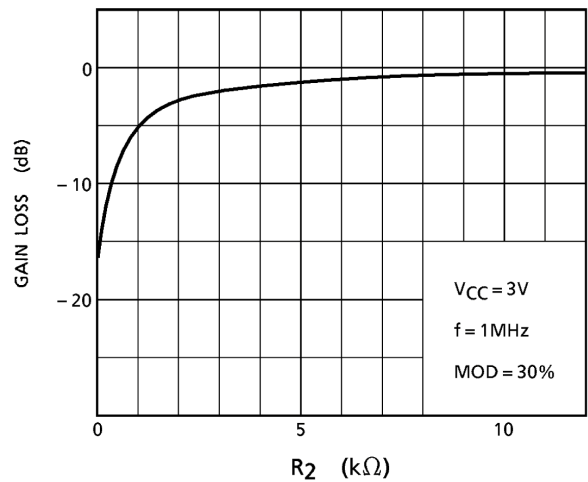

#### 4. AM low-cut circuit

- The AM low-cut action is carried out by the bypass of the high frequency component of the positive-feedback signal at the AF AMP stage. The external capacitor: C<sub>6</sub> by-passes this component.
- The cut-off frequency f<sub>L</sub> is determine by the internal resistance 22kΩ (typ.) and the external capacitor C<sub>6</sub> as following;

$$f_L = \frac{1}{2 \times \pi \times 22 \times 10^3 \times C_6} \text{ (Hz)}$$

- In the case of the AM low-cut function is not needed, set up the value of C<sub>6</sub> over 0.47μF. In the condition of C<sub>6</sub> ≥ 0.47μF, the frequency characteristic has flat response at the low frequency.

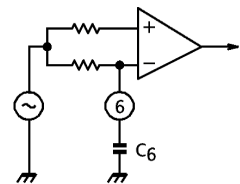

### 5. AM local oscillator buffer output

- The output impedance of AM local oscillator buffer output pin (pin(4)) is 750Ω (typ.) (cf.P.3)
- It is possible to reduce the output level to add the resistance between the pin(4) and V<sub>CC</sub> line. The signal waveform is the rectangular wave, and the level is 500mV<sub>p-p</sub> (f<sub>OSC</sub> = 1.45MHz, typ.)
- The higher local oscillation frequency (f<sub>OSC</sub>) to be, the lower buff output level to be owing to the load capacity. So, in the case that it is connected to other circuits, take care of the input capacity of these circuits and stray capacity of wire.

### 6. Tuning LED driver and stereo LED driver

- The tuning LED driver and stereo LED driver don't have current limit resistance shown in the right figure. So, it is necessary to add the current limit resistance: R<sub>10</sub>, R<sub>11</sub>.
- Set up the values of R<sub>10</sub>, R<sub>11</sub> to keep the drive currents I<sub>D10</sub>, I<sub>D11</sub> under 10mA.

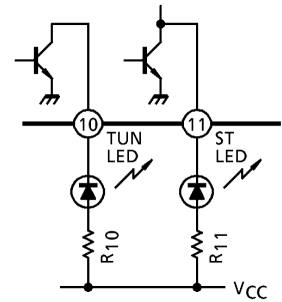

### 7.FM detection circuit

For the FM detection circuit,detection coil is able to use instead of ceramic discriminator.  
 Recommended circuit and recommended coil are as follows.  
 In this case, please take care that V<sub>in</sub> (lim.) falls a little.

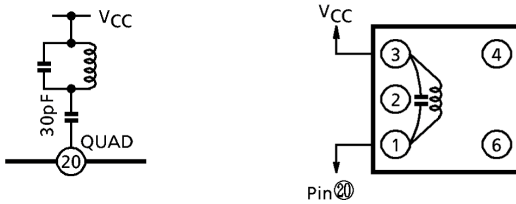

Test Frequency	C <sub>o</sub> (pF)	Q <sub>o</sub>	Turns				Wire (mmφ)	REF
			1-2	2-3	1-3	4-6		
10.7MHz	100	100	—	—	12	—	0.12 UEW	SUMIDA ELECTRIC CO., LTD 2153-4095-189 or equivalent

### 8. FM / AM switch and forced monaural switch

FM / AM switch over and stere / forced monaural switch over are done by internal PNP transistors ON / OFF which are connected to pin(16) and pin (17) respectively.

The threshold voltages of these PNP transistors are  $V_{th} = V_{CC}$ , and for switching, we recommend to use mechanical switch.

(Direct short to VCC line.)

In the case of the electrical switch over by transistor, set up  $V_{CE}$  (saturation voltage between collector and emitter) 50mV or less, otherwise there are some cases that it does not become the AM mode and force monaural mode.

When these external switches are ON, the currents which flow into pin(16) and pin(17) are 100 $\mu$ A and 20 $\mu$ A respectively. (Typical value at  $V_{CC} = 3V$ )

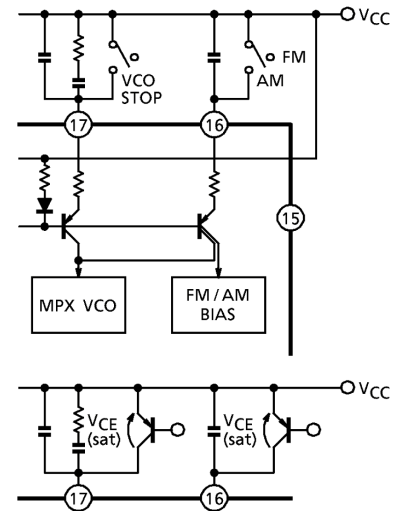

### Maximum Ratings ( $T_a = 25^\circ C$ )

Characteristic		Symbol	Rating	Unit
Supply voltage		$V_{CC}$	8	V
LED current		$I_{LED}$	10	mA
LED voltage		$V_{LED}$	8	V
Power dissipation	TA8132AN	PD (Note)	1200	mW
	TA8132AF		400	
Operating Temperature		$T_{opr}$	-25~75	$^\circ C$
Storage temperature		$T_{stg}$	-55~150	$^\circ C$

(Note): Derated above  $25^\circ C$  in the proportion of 9.6mW /  $^\circ C$  for TA8132AN, TA2012N and of 3.2mW /  $^\circ C$  for TA8132AF, TA2012F.

## Electrical characteristics

Unless Otherwise Specified,  $T_a = 25^\circ\text{C}$ ,  $V_{CC1} = 3\text{V}$ ,  $SW_1 \rightarrow 10\text{k}\Omega$ ,  $SW_3 \rightarrow \text{OFF}$   
 FM IF:  $f = 10.7\text{MHz}$ ,  $\Delta f = \pm 22.5\text{kHz}$ ,  $f_m = 1\text{kHz}$   
 AM:  $f = 1\text{MHz}$ ,  $\text{MOD} = 30\%$ ,  $f_m = 1\text{kHz}$   
 MPX:  $f_m = 1\text{kHz}$

Characteristic		Symbol	Test Circuit	Test Condition	Min.	Typ.	Max.	Unit	
Supply current		$I_{CC}(\text{FM})$	1	FM mode, $V_{in} = 0$	—	11.0	14.0	mA	
		$I_{CC}(\text{AM})$	1	AM mode, $V_{in} = 0$	—	10.5	13.5		
FM IF	Input limiting voltage	$V_{in}(\text{lim.})$	1	-3dB limiting point	41	46	51	$\text{dB}\mu\text{V}$ EMF	
	Recovered output voltage	$V_{OD}$	1	$V_{in} = 80\text{dB}\mu\text{V}$ EMF	50	75	100	$\text{mV}_{\text{rms}}$	
	Signal to noise ratio	S / N	1	$V_{in} = 80\text{dB}\mu\text{V}$ EMF	—	65	—	dB	
	Total harmonic distortion	THD	1	$V_{in} = 80\text{dB}\mu\text{V}$ EMF	—	0.2	—	%	
	AM rejection ratio	AMR	1	$V_{in} = 80\text{dB}\mu\text{V}$ EMF	—	38	—	dB	
	LED on sensitivity	$V_L$	1	$I_L = 1\text{mA}$	48	53	58	$\text{dB}\mu\text{V}$ EMF	
	IF count output frequency	IF	$f_{IF}(\text{FM})$	1	$V_{in} = 80\text{dB}\mu\text{V}$ EMF, $SW_2 \rightarrow V_{CC}$ , $SW_3 \rightarrow \text{ON}$	—	10.7	—	MHz
		1 / 8 IF	$f_{1/8\text{IF}}(\text{FM})$	1	$V_{in} = 80\text{dB}\mu\text{V}$ EMF, $SW_2 \rightarrow \text{GND}$ , $SW_3 \rightarrow \text{ON}$	1.3374	1.3375	1.3376	
	IF count output voltage	IF	$V_{IF}(\text{FM})$	1	$V_{in} = 61\text{dB}\mu\text{V}$ EMF, $SW_2 \rightarrow V_{CC}$ , $SW_3 \rightarrow \text{ON}$	350	500	—	$\text{mV}_{\text{p-p}}$
		1 / 8 IF	$V_{1/8\text{IF}}(\text{FM})$	1	$V_{in} = 61\text{dB}\mu\text{V}$ EMF, $SW_2 \rightarrow \text{GND}$ , $SW_3 \rightarrow \text{ON}$	350	500	—	
IF count output sensitivity		$IF_{\text{sens.}}(\text{FM})$	1	$SW_1 \rightarrow 0$ , $SW_2 \rightarrow \text{GND}$ , $SW_3 \rightarrow \text{ON}$	—	76	—	$\text{dB}\mu\text{V}$ EMF	
				$SW_1 \rightarrow 510\Omega$ , $SW_2 \rightarrow \text{GND}$ , $SW_3 \rightarrow \text{ON}$	—	68	—		
				$SW_1 \rightarrow 0$ , $SW_2 \rightarrow V_{CC}$ , $SW_3 \rightarrow \text{ON}$	—	77	—		
				$SW_1 \rightarrow 510\Omega$ , $SW_2 \rightarrow V_{CC}$ , $SW_3 \rightarrow \text{ON}$	—	69	—		

Characteristic		Symbol	Test Circuit	Test Condition	Min.	Typ.	Max.	Unit
AM	Gain	$G_V$	1	$V_{in} = 26\text{dB}\mu\text{V EMF}$	28	57	85	$\text{mV}_{\text{rms}}$
	Recovered output voltage	$V_{OD}$	1	$V_{in} = 60\text{dB}\mu\text{V EMF}$	50	75	100	
	Signal to noise ratio	S / N	1	$V_{in} = 60\text{dB}\mu\text{V EMF}$	—	41	—	dB
	Total harmonic distortion	THD	1	$V_{in} = 60\text{dB}\mu\text{V EMF}$	—	1.0	—	%
	LED on sensitivity	$V_L$	1	$I_L = 1\text{mA}$	21	26	31	$\text{dB}\mu\text{V EMF}$
	Local OSC buff. output voltage	$V_{OSC (AM)}$	1	$f_{OSC} = 1.45\text{MHz}$	350	500	—	$\text{mV}_{\text{p-p}}$
			2	$f_{OSC} = 27\text{MHz}$	—	500	—	
	IF count output voltage	$V_{IF (AM)}$	1	$V_{in} = 39\text{dB}\mu\text{V EMF}, SW_3 \rightarrow \text{ON}$	350	500	—	$\text{mV}_{\text{p-p}}$
IF count output sensitivity	$IF_{\text{sens. (AM)}}$	1	$SW_1 \rightarrow 0, SW_2 \rightarrow \text{GND}, SW_3 \rightarrow \text{ON}$	—	49	—	$\text{dB}\mu\text{V EMF}$	
			$SW_1 \rightarrow 510\Omega, SW_2 \rightarrow \text{GND}, SW_3 \rightarrow \text{ON}$	—	42	—		
			$SW_1 \rightarrow 0, SW_2 \rightarrow V_{CC}, SW_3 \rightarrow \text{on}$	—	49	—		
			$SW_1 \rightarrow 510\Omega, SW_2 \rightarrow V_{CC}, SW_3 \rightarrow \text{ON}$	—	42	—		
Pin(19) output resistance	$R_{19}$	1	FM mode	—	0.6	—	k $\Omega$	
			AM mode	—	12	—		

Characteristic		Symbol	Test Circuit	Test Condition	Min.	Typ.	Max.	Unit		
MPX	Input resistance	$R_{IN}$	1	—	—	25	—	k $\Omega$		
	Output resistance	$R_{OUT}$	1	—	—	5	—			
	Max. composite signal input voltage		$V_{in\ MAX}$ (stereo)	1	L + R = 90%, P = 10% THD = 3%, SW <sub>g</sub> →LPF: ON	—	350	—	mV <sub>rms</sub>	
	Separation		Sep	—	L + R = 135mV <sub>rms</sub> P = 15mV <sub>rms</sub> , SW <sub>g</sub> →LPF: ON	$f_m = 100\text{kHz}$	—	42	—	dB
						$f_m = 1\text{kHz}$	35	42	—	
						$f_m = 10\text{kHz}$	—	42	—	
	Total harmonic distortion	Monaural	THD (monaural)	1	$V_{in} = 150\text{mV}_{rms}$ (mono)  L + R = 135mV <sub>rms</sub> , P = 15mV <sub>rms</sub> , SW <sub>g</sub> →LPF: ON	—	0.2	—	%	
		Stereo	THD (stereo)							
	Voltage gain		$G_V$ (MPX)	1	$V_{in} = 150\text{mV}_{rms}$ (mono)	-5	-3	-1	dB	
	Channel balance		C.B.	1	$V_{in} = 150\text{mV}_{rms}$ (mono)	-2	0	2	dB	
	Stereo LED sensitivity	ON	$V_L$ (ON)	1	Pilot input	—	8	15	mV <sub>rms</sub>	
		OFF	$V_L$ (OFF)							
Stereo LED hysteresis		$V_H$	1	To LED turn off from LED turn on	—	2	—	mV <sub>rms</sub>		
Capture range		C.R.	1	P = 15mV <sub>rms</sub>	—	±1.3	—	%		
Signal to noise ratio		S / N	1	$V_{in} = 150\text{mV}_{rms}$ (mono)	—	78	—	dB		

## Test Circuit 1

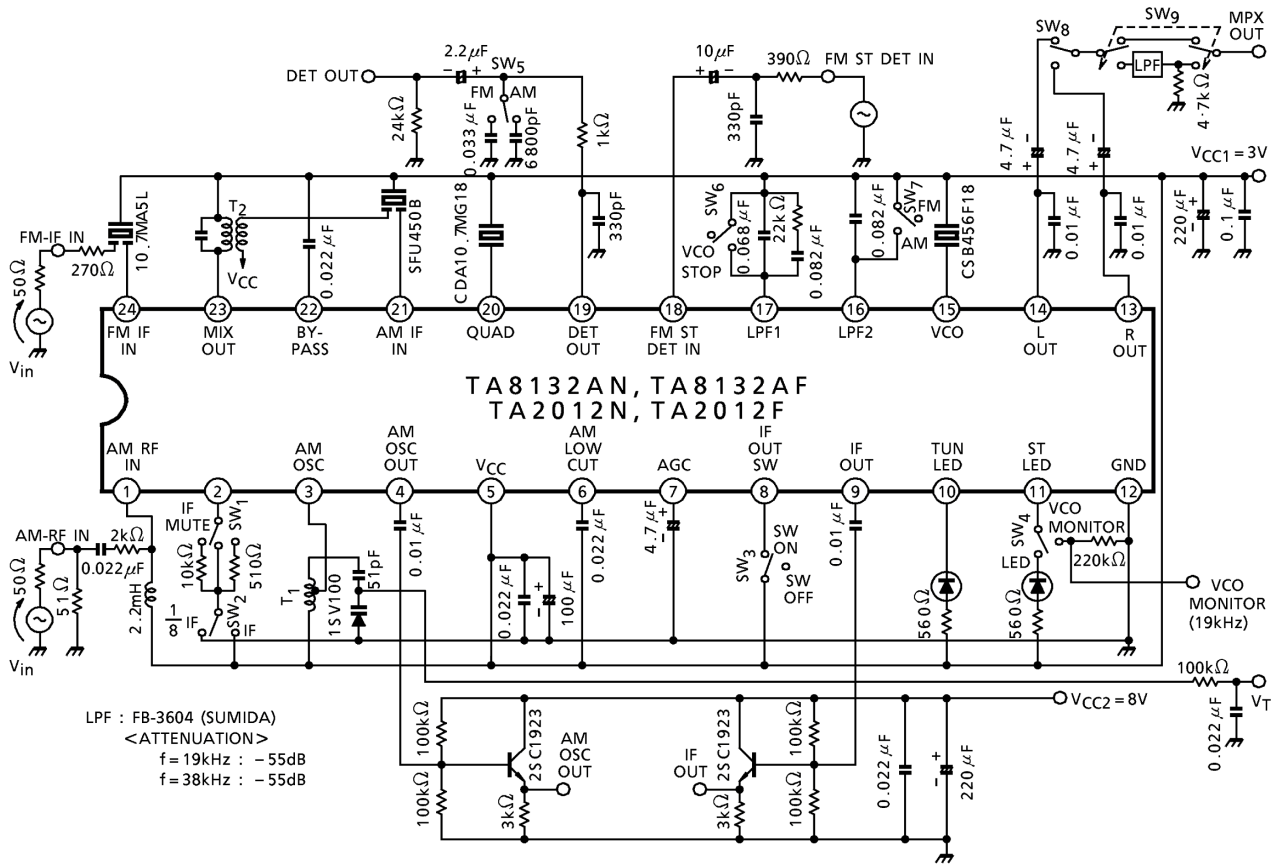

## Coil Data (test circuit 1)

Coil No.	f	L (μH)	C <sub>0</sub> (pF)	Q <sub>0</sub>	Turn				Wire (mm)	RED. (Coil No.)
					1-2	2-3	1-3	4-6		
T <sub>1</sub> AM OSC	796kHz	288	—	115	13	73	—	—	0.08 UEW	4147-1356-038 (S)
T <sub>2</sub> AM IFT	455kHz	—	180	120	—	—	180	15	0.06 UEW	2150-2162-165 (S)

(S): SUMIDA ELECTRIC Co., Ltd.

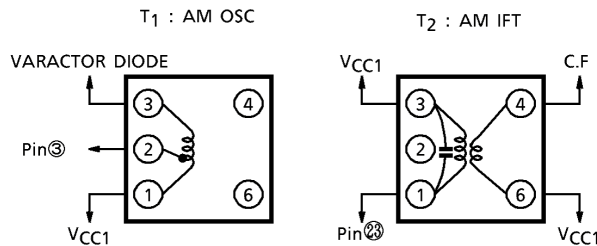

## Test Circuit 2

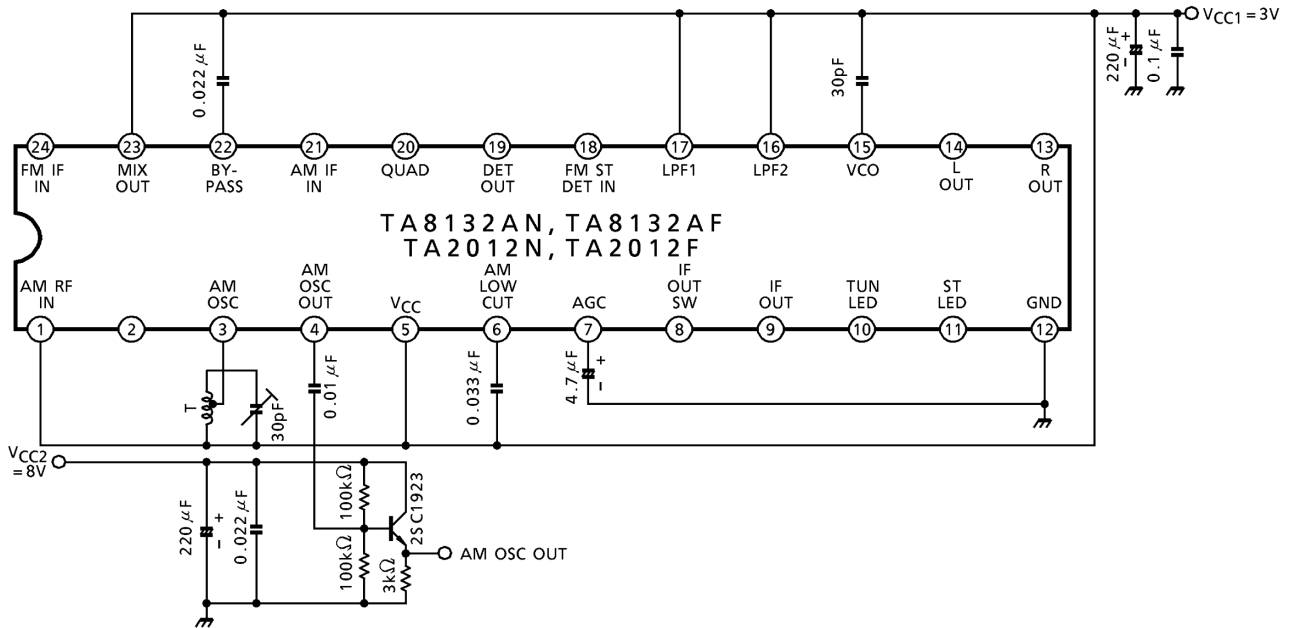

## Coil Data (test circuit 2)

Coil No.	f	L (μH)	C <sub>o</sub> (pF)	Q <sub>o</sub>	Turn				Wire (mm)	REF. (Coil No.)
					1-2	2-3	1-3	4-6		
T AM OSC	7.96MHz	1.4	—	84	1	6	7	—	0.08 UEW	(T) 7PL-1344Y

(T): TOKO Co., Ltd.

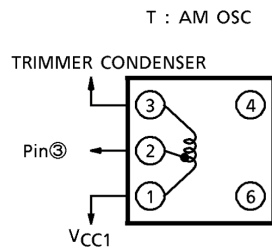

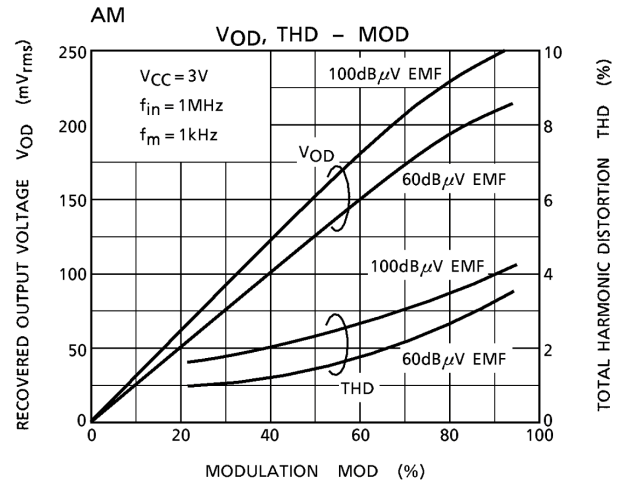
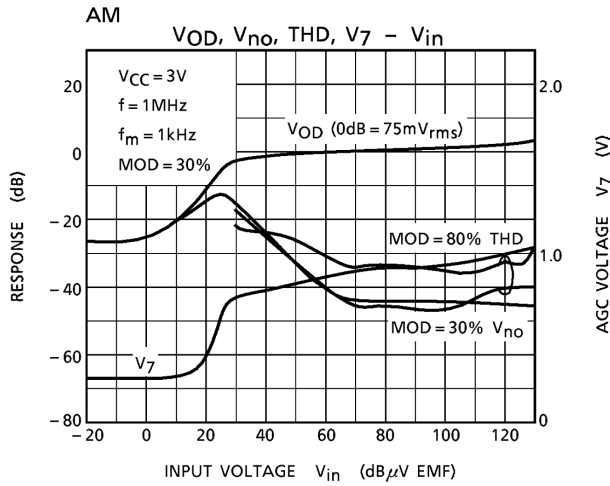
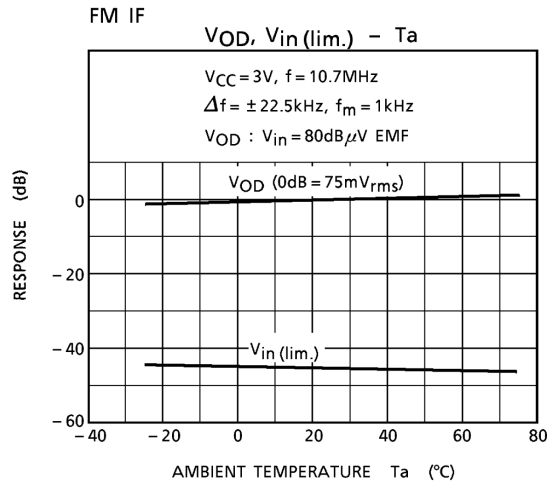
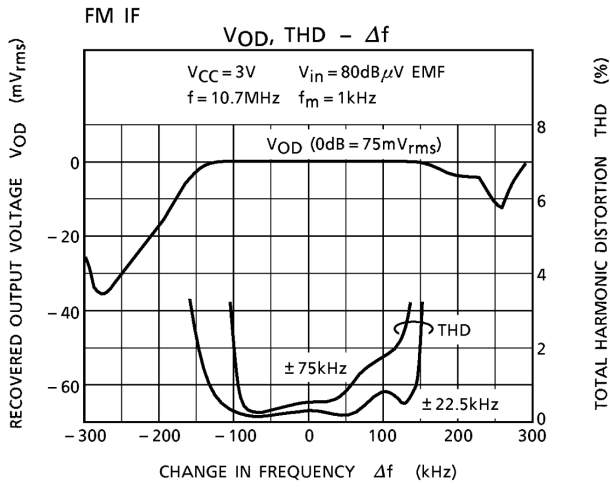
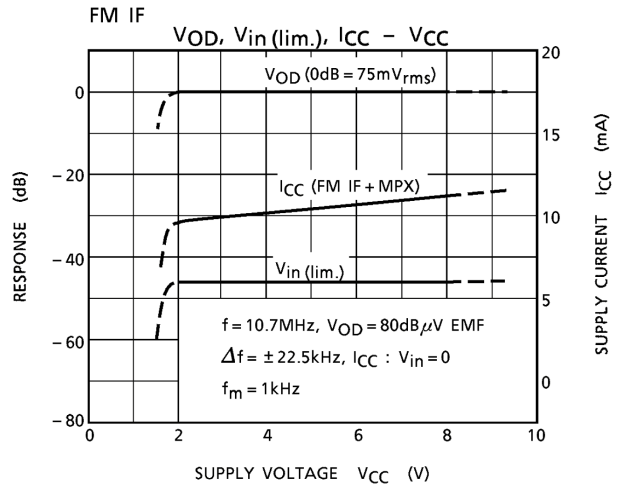
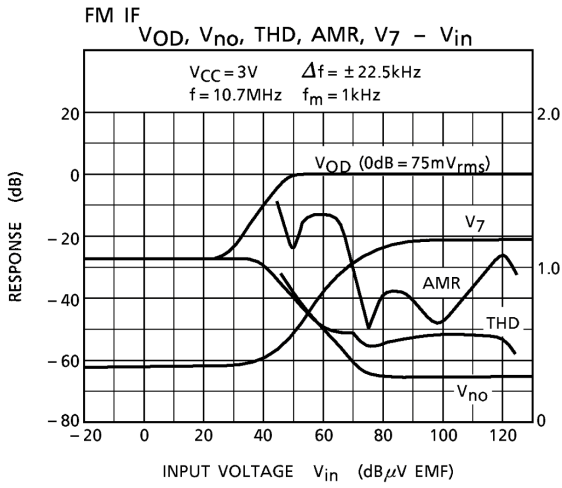

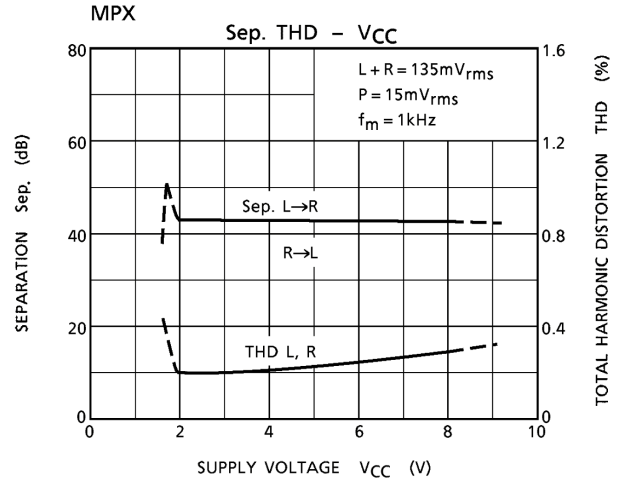
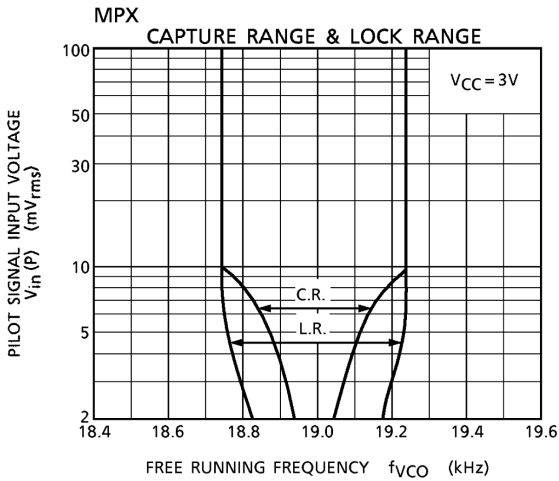
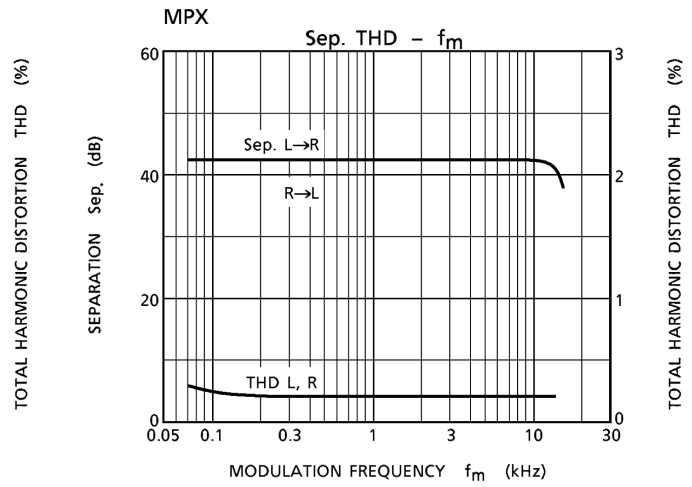
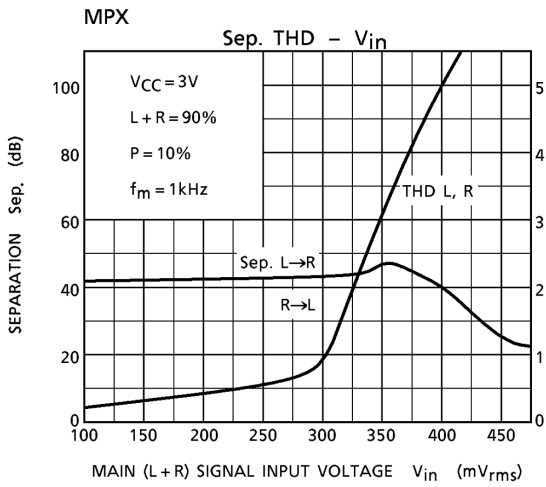
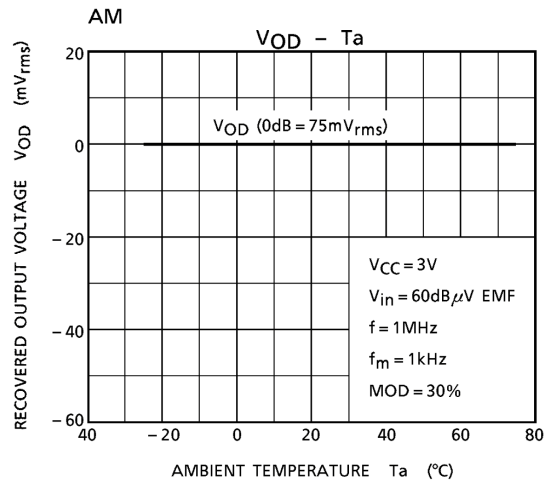
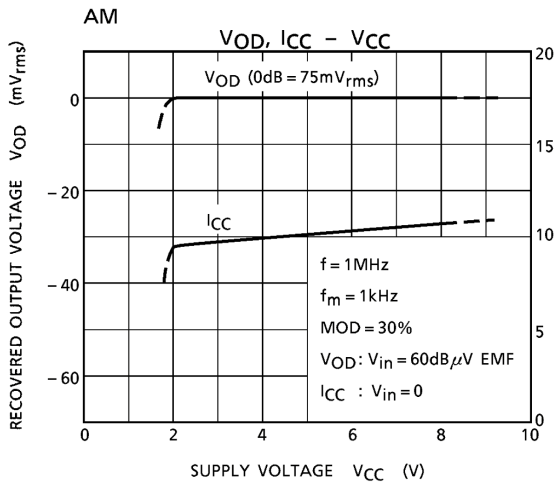

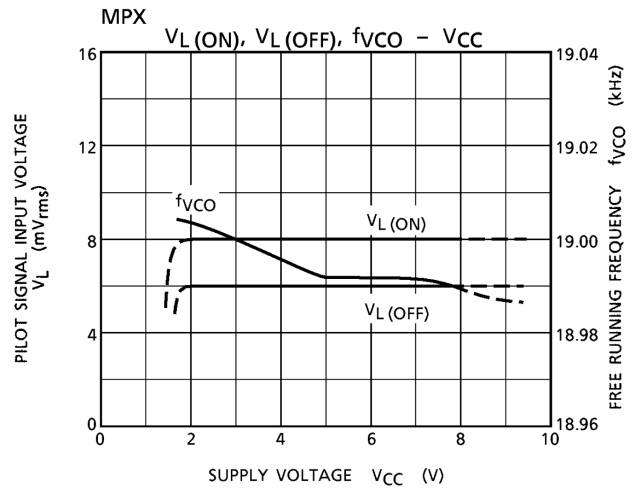
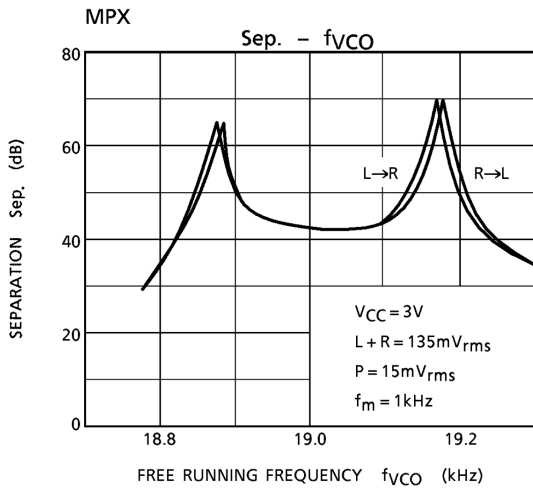

**Package Dimensions**

SDIP24-P-300-1.78

Unit : mm

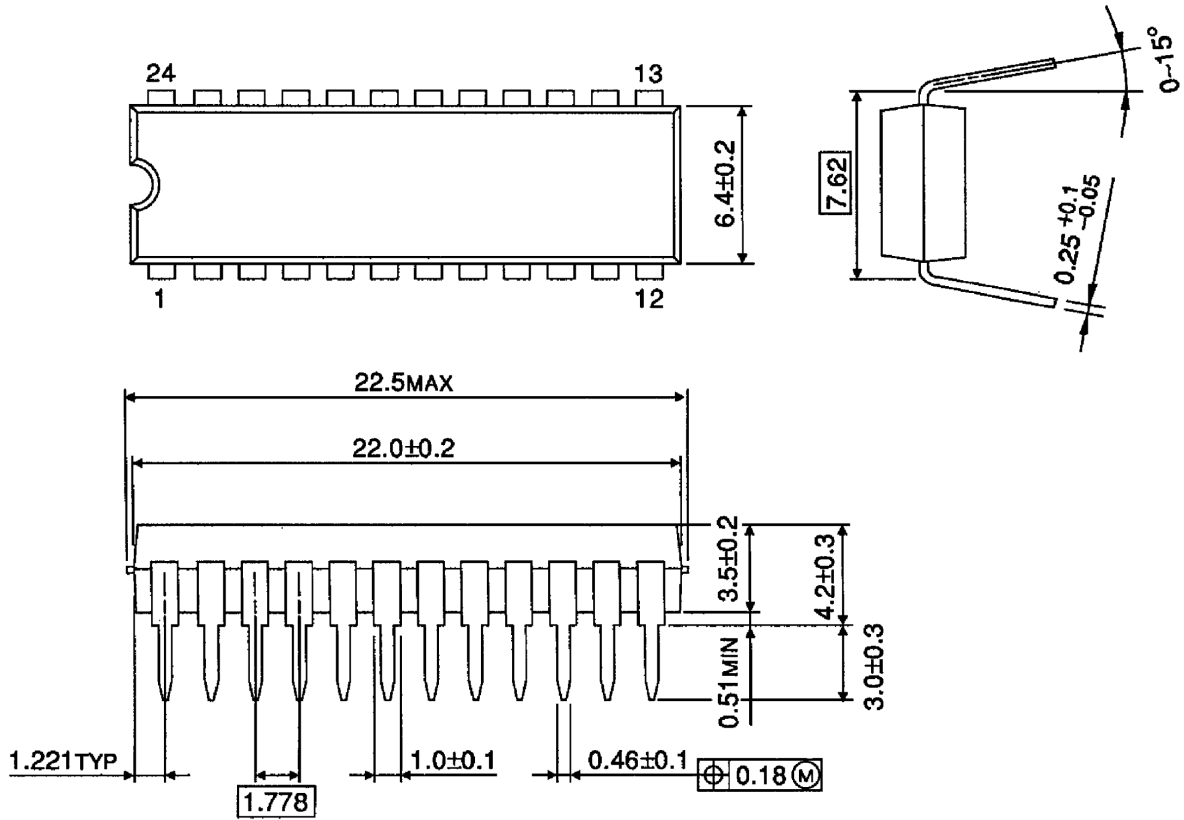

Weight: 1.2g (typ.)

**Package Dimensions**

SSOP24-P-300-1.00

Unit : mm

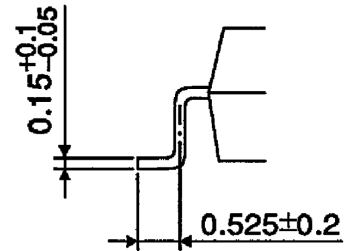
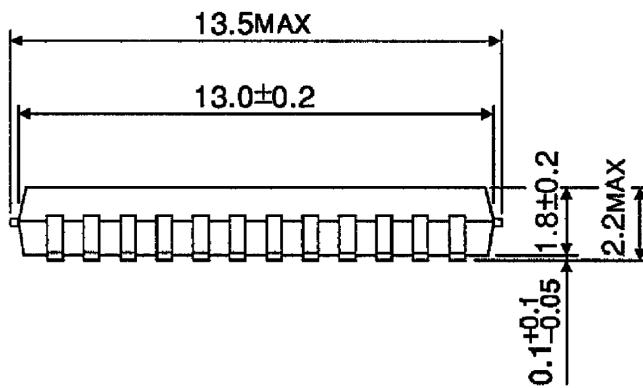
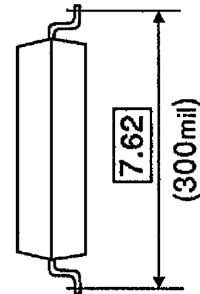
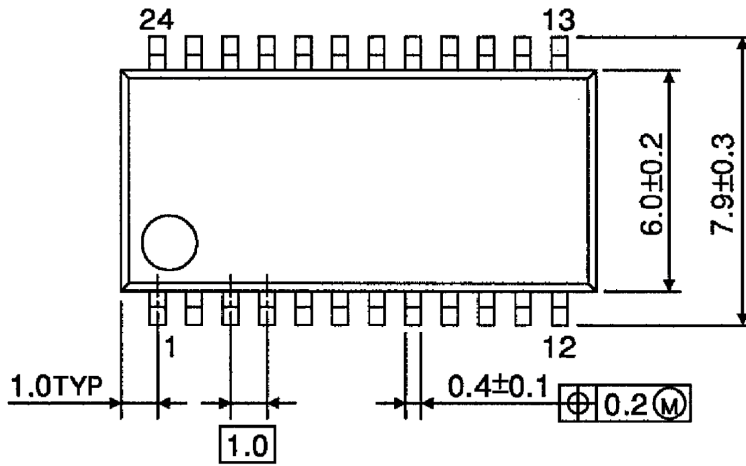

Weight: 0.31g (typ.)

**RESTRICTIONS ON PRODUCT USE**

000707EBA

- TOSHIBA is continually working to improve the quality and reliability of its products. Nevertheless, semiconductor devices in general can malfunction or fail due to their inherent electrical sensitivity and vulnerability to physical stress. It is the responsibility of the buyer, when utilizing TOSHIBA products, to comply with the standards of safety in making a safe design for the entire system, and to avoid situations in which a malfunction or failure of such TOSHIBA products could cause loss of human life, bodily injury or damage to property.  
In developing your designs, please ensure that TOSHIBA products are used within specified operating ranges as set forth in the most recent TOSHIBA products specifications. Also, please keep in mind the precautions and conditions set forth in the "Handling Guide for Semiconductor Devices," or "TOSHIBA Semiconductor Reliability Handbook" etc..
- The TOSHIBA products listed in this document are intended for usage in general electronics applications (computer, personal equipment, office equipment, measuring equipment, industrial robotics, domestic appliances, etc.). These TOSHIBA products are neither intended nor warranted for usage in equipment that requires extraordinarily high quality and/or reliability or a malfunction or failure of which may cause loss of human life or bodily injury ("Unintended Usage"). Unintended Usage include atomic energy control instruments, airplane or spaceship instruments, transportation instruments, traffic signal instruments, combustion control instruments, medical instruments, all types of safety devices, etc.. Unintended Usage of TOSHIBA products listed in this document shall be made at the customer's own risk.
- The products described in this document are subject to the foreign exchange and foreign trade laws.
- The information contained herein is presented only as a guide for the applications of our products. No responsibility is assumed by TOSHIBA CORPORATION for any infringements of intellectual property or other rights of the third parties which may result from its use. No license is granted by implication or otherwise under any intellectual property or other rights of TOSHIBA CORPORATION or others.
- The information contained herein is subject to change without notice.