

Silicon NPN Power Transistors

2SD1913

DESCRIPTION

- With TO-220F package
- Complement to type 2SB1274
- High reliability.
- High breakdown voltage
- Low saturation voltage.
- Wide area of safe operation

APPLICATIONS

- 60V/3A low-frequency power amplifier
- General power amplifier applications

PINNING

PIN	DESCRIPTION
1	Base
2	Collector
3	Emitter

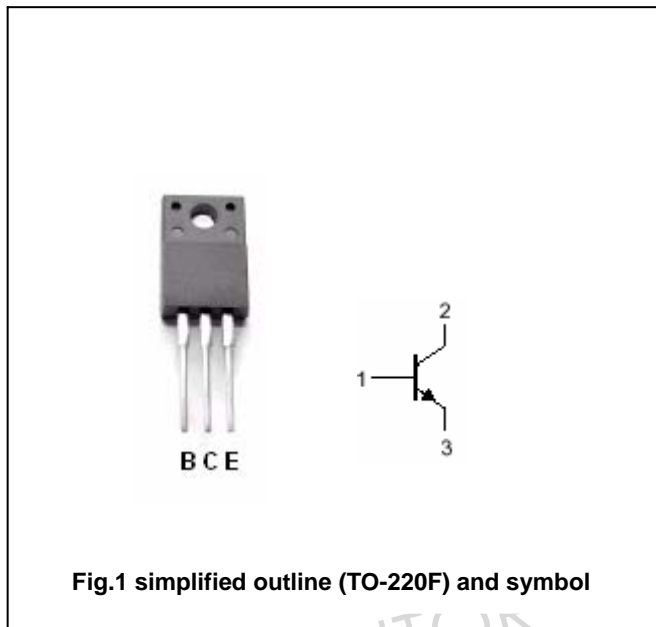

Fig.1 simplified outline (TO-220F) and symbol

Absolute maximum ratings (Ta=25)

SYMBOL	PARAMETER	CONDITIONS	VALUE	UNIT
V_{CBO}	Collector-base voltage	Open emitter	60	V
V_{CEO}	Collector-emitter voltage	Open base	60	V
V_{EBO}	Emitter-base voltage	Open collector	6	V
I_C	Collector current		3	A
I_{CM}	Collector current-peak		8	A
P_C	Collector dissipation	$T_C=25$	20	W
			2	
T_j	Junction temperature		150	
T_{stg}	Storage temperature		-55~150	

Silicon NPN Power Transistors

2SD1913

CHARACTERISTICS

T_j=25 unless otherwise specified

SYMBOL	PARAMETER	CONDITIONS	MIN	TYP.	MAX	UNIT
V _{(BR)CBO}	Collector-base breakdown voltage	I _C =1mA; I _E =0	60			V
V _{(BR)CEO}	Collector-emitter breakdown voltage	I _C =5mA; R _{BE} =	60			V
V _{(BR)EBO}	Base-emitter breakdown voltage	I _E =1mA; I _C =0	6			V
V _{CEsat}	Collector-emitter saturation voltage	I _C =2A; I _B =0.2A		0.4	1.0	V
V _{BE}	Base-emitter voltage	I _C =0.5A; V _{CE} =5V		0.8	1.0	V
I _{CBO}	Collector cut-off current	V _{CB} =40V; I _E =0			0.1	mA
I _{EBO}	Emitter cut-off current	V _{EB} =4V; I _C =0			0.1	mA
h _{FE-1}	DC current gain	I _C =0.5A; V _{CE} =5V	70		280	
h _{FE-2}	DC current gain	I _C =3A; V _{CE} =5V	20			
f _T	Transition frequency	I _C =0.5A; V _{CE} =5V		100		MHz
C _{ob}	Output capacitance	I _E =0; V _{CB} =10V; f=1MHz		40		pF

◆ h_{FE-1} classifications

Q	R	S
70-140	100-200	140-280

Silicon NPN Power Transistors

2SD1913

PACKAGE OUTLINE

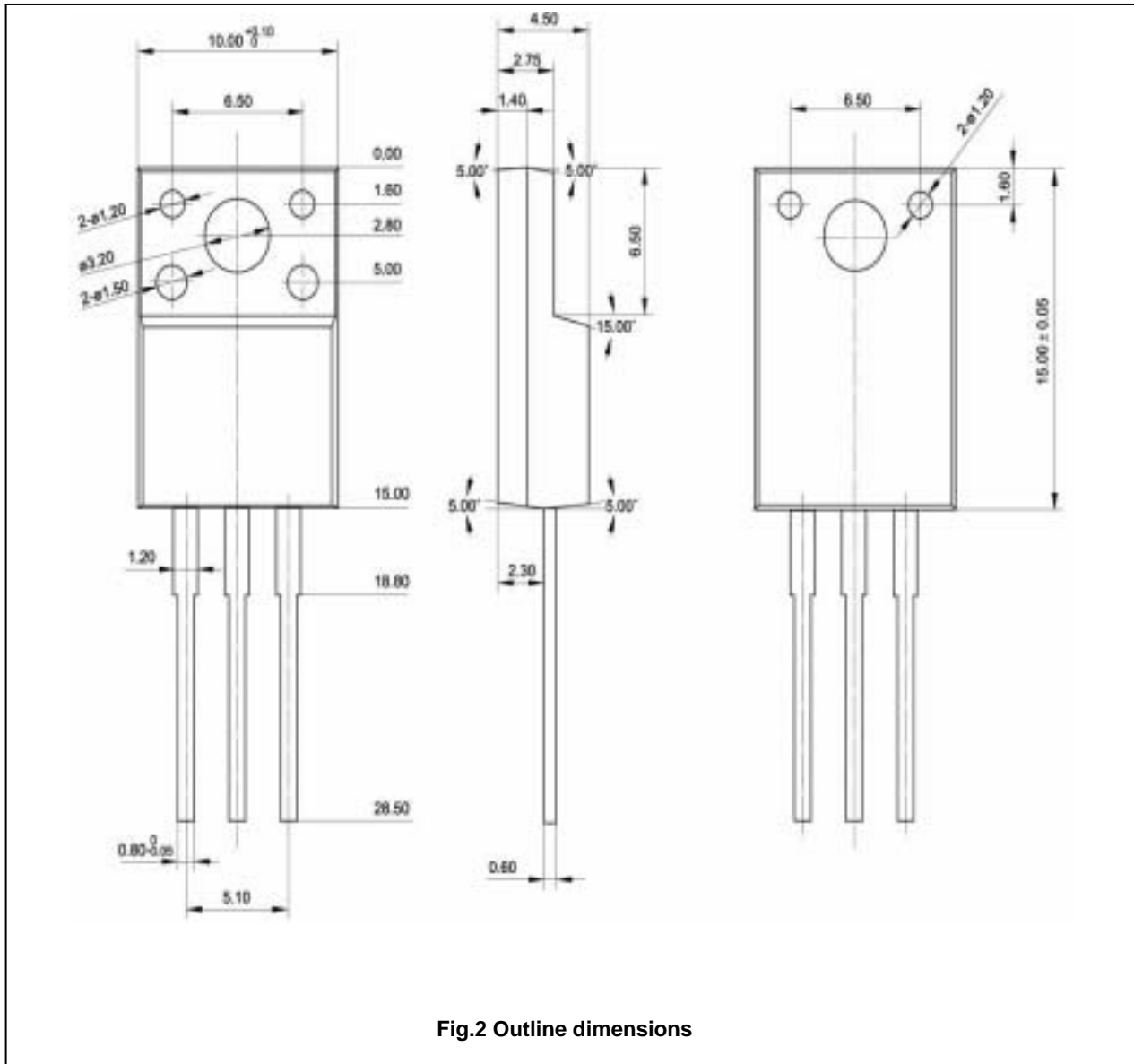

Fig.2 Outline dimensions

Silicon NPN Power Transistors

2SD1913

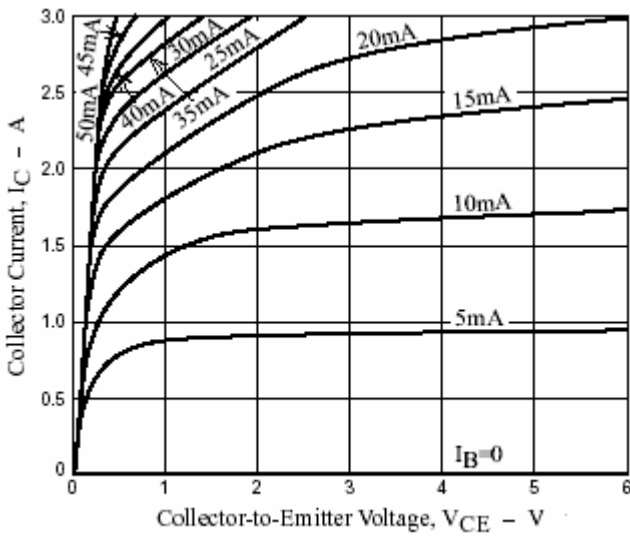

Fig.3 Static Characteristic

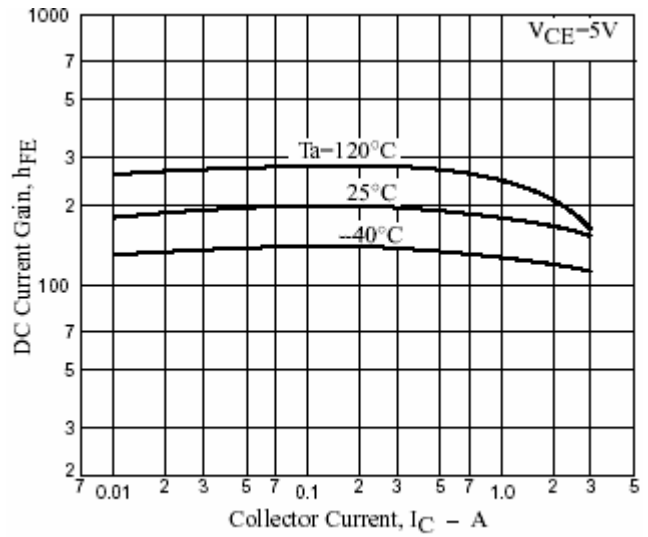

Fig.4 DC current Gain

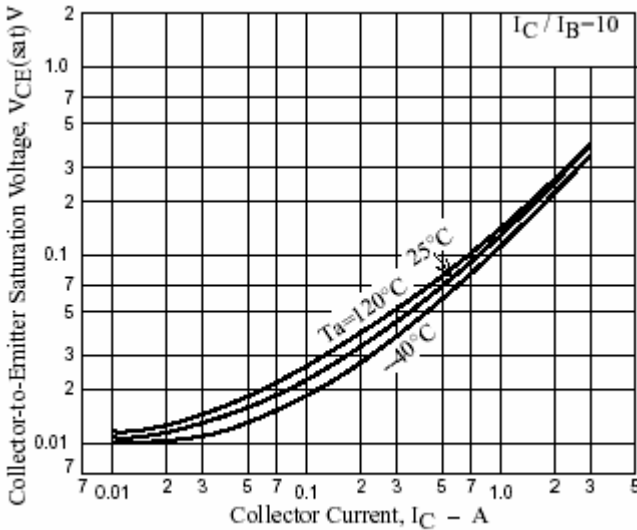

Fig.5 Collector-Emmitter Saturation Voltage

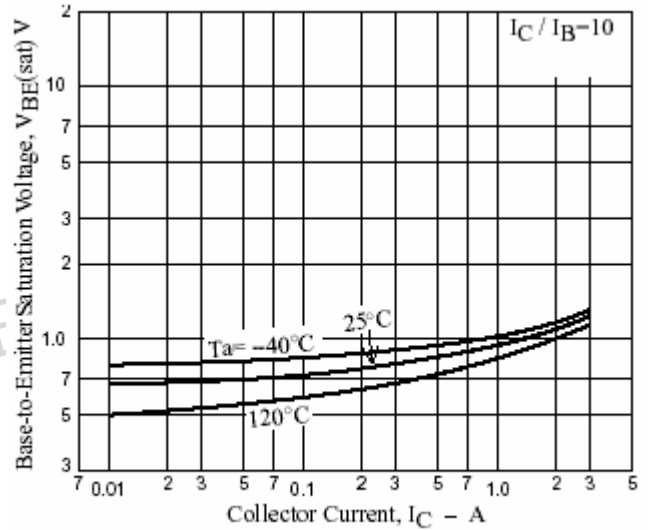

Fig.6 Base-Emmitter Saturation Voltage

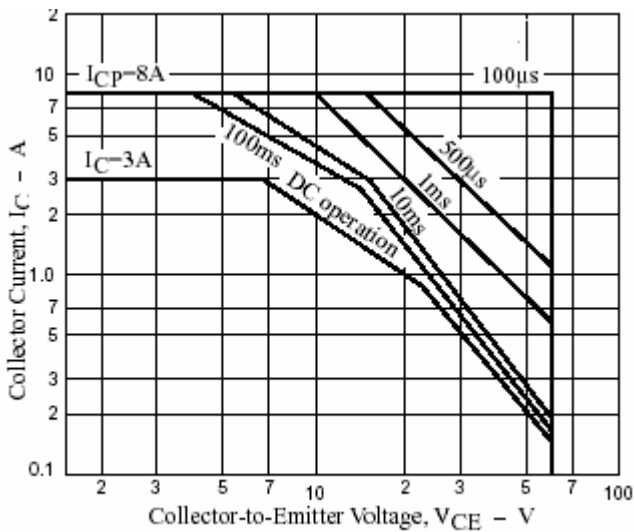

Fig.7 Safe Operating Area