

SOT-23 Formed SMD Package

**BC849
BC850**

SILICON PLANAR EPITAXIAL TRANSISTORS

N-P-N transistors

Marking

- BC849 = 2D
- BC849B = 2B
- BC849C = 2C
- BC850 = 2H
- BC850B = 2F
- 8C850C = 2G

**PACKAGE OUTLINE DETAILS
ALL DIMENSIONS IN mm**

Pin configuration

- 1 = BASE
- 2 = EMITTER
- 3 = COLLECTOR

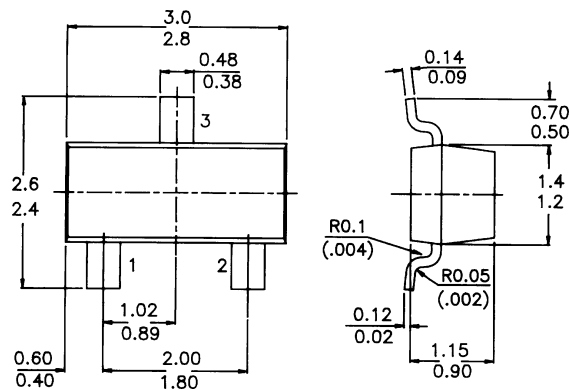
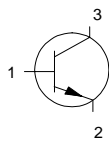

ABSOLUTE MAXIMUM RATINGS

		BC849	BC850	
Collector-emitter voltage ($V_{BE} = 0$)	V_{CES}	max. 30	50	V
Collector-emitter voltage (open base)	V_{CE0}	max. 30	45	V
Collector current (peak value)	I_{CM}	max. 200	200	mA
Total power dissipation up to $T_{amb} = 25\text{ }^{\circ}\text{C}$	P_{tot}	max. 250	250	mW
Junction temperature	T_j	max. 150	150	$^{\circ}\text{C}$
Small-signal current gain $I_C = 2\text{ mA}; V_{CE} = 5\text{ V}; f = 1\text{ kHz}$	h_{fe}	> 240	240	
		< 900	900	
Transition frequency $I_C = 10\text{ mA}; V_{CE} = 5\text{ V}; f = 100\text{ MHz}$	f_T	> 100	> 100	MHz
Noise figure at $R_S = 2\text{ k}\Omega$ $I_C = 200\text{ }\mu\text{A}; V_{CE} = 5\text{ V}$ $f = 30\text{ Hz to }15\text{ kHz}$	F	typ. 1,4	1,4	dB
		< 4	3	dB
$f = 1\text{ kHz}; B = 200\text{ Hz}$	F	typ. 1,2	1	dB
$f = 10\text{ Hz to }50\text{ Hz}$ (equivalent noise voltage)	V_n	< —	0,135	mV

BC849
BC850

RATINGS (at $T_A = 25^\circ\text{C}$ unless otherwise specified)

Limiting values

		BC849	BC850	
Collector-base voltage (open emitter)	V_{CBO} max.	30	50	V
Collector-emitter voltage ($V_{BE} = 0$)	V_{CES} max.	30	50	V
Collector-emitter voltage (open base)	V_{CEO} max.	30	45	V
Emitter-base voltage (open collector)	V_{EBO} max.	5		V
Collector current (d.c.)	I_C max.	100		mA
Collector current (peak value)	I_{CM} max.	200		mA
Emitter current (peak value)	$-I_{EM}$ max.	200		mA
Base current (peak value)	I_{BM} max.	200		mA
Total power dissipation up to $T_{amb} = 25^\circ\text{C}$	P_{tot} max.	250		mW
Storage temperature	T_{stg}	-55 to +150		$^\circ\text{C}$
Junction temperature	T_j max.	150		$^\circ\text{C}$

THERMAL RESISTANCE

From junction to ambient*

$$R_{th\ j-a} = 500\ \text{KW}$$

CHARACTERISTICS

$T_j = 25^\circ\text{C}$ unless otherwise specified

Collector cut-off current

$I_E = 0; V_{CB} = 30\ \text{V}$

$I_E = 0; V_{CB} = 30\ \text{V}; T_j = 150^\circ\text{C}$

Base emitter voltage

$I_C = 2\ \text{mA}; V_{CE} = 5\ \text{V}$

$$I_{CBO} < 15\ \text{nA}$$

$$I_{CBO} < 5\ \mu\text{A}$$

$$V_{BE} \text{ typ. } 660\ \text{mV}$$

$$580\ \text{to } 700\ \text{mV}$$

$$V_{BE} < 770\ \text{mV}$$

$I_C = 10\ \text{mA}; V_{CE} = 5\ \text{V}$

Saturation voltages

$I_C = 10\ \text{mA}; I_B = 0,5\ \text{mA}$

$$V_{CEsat} \text{ typ. } 90\ \text{mV}$$

$$250\ \text{mV}$$

$$V_{BEsat} \text{ typ. } 700\ \text{mV}$$

$I_C = 100\ \text{mA}; I_B = 5\ \text{mA}$

$$V_{CEsat} \text{ typ. } 200\ \text{mV}$$

$$< 600\ \text{mV}$$

$$V_{BEsat} \text{ typ. } 900\ \text{mV}$$

Collector capacitance at $f = 1\ \text{MHz}$

$I_E = I_e = 0; V_{CB} = 10\ \text{V}$

Transition frequency at $f = 100\ \text{MHz}$

$I_C = 10\ \text{mA}; V_{CE} = 5\ \text{V}$

$$C_c \text{ typ. } 2,5\ \text{pF}$$

$$f_T > 100\ \text{MHz}$$

Small signal current gain at $f = 1\ \text{kHz}$

$I_C = 2\ \text{mA}; V_{CE} = 5\ \text{V}$

Noise figure at $R_S = 2\ \text{k}\Omega$,

$I_C = 200\ \mu\text{A}; V_{CE} = 5\ \text{V}$

$f = 30\ \text{Hz to } 15\ \text{kHz}$

$f = 1\ \text{kHz}; B = 200\ \text{Hz}$

$$h_{fe} \quad 110 - 800$$

BC849 **BC850**

$$\text{typ. } 1,4 \quad | \quad 1,4 \quad \text{dB}$$

$$F < 4 \quad | \quad 3 \quad \text{dB}$$

$$\text{typ. } 1,2 \quad | \quad 1 \quad \text{dB}$$

$$F < 4 \quad | \quad 4 \quad \text{dB}$$

BC849
BC850

Equivalent noise voltage at $R_S = 2 \text{ k}\Omega$

$I_C = 200 \mu\text{A}; V_{CE} = 5 \text{ V}$
 $f = 10 \text{ Hz to } 50 \text{ Hz}; T_{amb} = 25^\circ\text{C}$

V_n max. — 0,135 mV

	BC849B	BC849C
	BC850B	BC850C

D.C. current gain

$I_C = 10 \mu\text{A}; V_{CE} = 5 \text{ V}$

h_{FE} typ. 150 270

> 200 420

$I_C = 2 \text{ mA}; V_{CE} = 5 \text{ V}$

h_{FE} typ. 290 520

< 450 800

Disclaimer

The product information and the selection guides facilitate selection of the CDIL's Discrete Semiconductor Device(s) best suited for application in your product(s) as per your requirement. It is recommended that you completely review our Data Sheet(s) so as to confirm that the Device(s) meet functionality parameters for your application. The information furnished on the CDIL Web Site/ CD is believed to be accurate and reliable. CDIL however, does not assume responsibility for inaccuracies or incomplete information. Furthermore, CDIL does not assume liability whatsoever, arising out of the application or use of any CDIL product; neither does it convey any license under its patent rights nor rights of others. These products are not designed for use in life saving/support appliances or systems. CDIL customers selling these products (either as individual Discrete Semiconductor Devices or incorporated in their end products), in any life saving/support appliances or systems or applications do so at their own risk and CDIL will not be responsible for any damages resulting from such sale(s).

CDIL strives for continuous improvement and reserves the right to change the specifications of its products without prior notice.



CDIL is a registered Trademark of
Continental Device India Limited

C-120 Naraina Industrial Area, New Delhi 110 028, India.
Telephone + 91-11-2579 6150, 5141 1112 Fax + 91-11-2579 5290, 5141 1119
email@cdil.com www.cdilsemi.com