

# MC44002 MC44007

## Advance Information

# Chroma 4 Multistandard Video Processor

The MC44002/7 is a highly advanced circuit which performs most of the basic functions required for a color TV. All of its advanced features are under processor control via an I<sup>2</sup>C bus, enabling potentiometer controls to be removed completely. In this way the component count may be reduced dramatically, allowing significant cost savings together with the possibility of implementing sophisticated automatic test routines. Using the MC44002/7, TV manufacturers will be able to build a standard chassis for anywhere in the world. Additional features include 4 selectable matrix modes (primarily for NTSC), fast beam current limiting and 16:9 display.

- Operation from a Single 5.0 V Supply; Typical Current Consumption Only 120 mA
- Full PAL/SECAM/NTSC Capability (4 Matrix Modes)
- Dual Composite Video or S-VHS Inputs
- All Chroma/Luma Channel Filtering, and Luma Delay Line Are Integrated Using Sampled Data Filters Requiring No External Components
- Filters Automatically Commutate with Change of Standard
- Chroma Delay Line is Realized with a 16 Pin Companion Device, the MC44140
- RGB Drives Incorporate Contrast and Brightness Controls and Auto Gray Scale
- Switched RGB Inputs with Separate Saturation Control
- Auxiliary Y, R-Y, B-Y Inputs
- Line Timebase Featuring H-Phase Control, Time Constant and Switchable Phase Detector Gain
- Vertical Timebase Incorporating Vertical Geometry Corrections
- 16:9 Display Mode Capability
- E-W Parabola Drive Incorporating Horizontal Geometry Corrections
- Beam Current Monitor with Breathing Compensation
- Analog Contrast Control, Allowing Fast Beam Current Limitation
- MC44007 Decoders PAL/NTSC Only

### MAXIMUM RATINGS (T<sub>A</sub> = 25°C, unless otherwise noted.)

Rating	Pin	Symbol	Value	Unit
Supply Voltage	35	V <sub>CC</sub>	6.0	Vdc
Operating Ambient Temperature	–	T <sub>A</sub>	0 to +70	°C
Storage Temperature	–	T <sub>stg</sub>	–65 to +150	°C
Junction Temperature	–	T <sub>J</sub>	+150	°C
Drive Output Sink Current	12	I <sub>12</sub>	2.0	mA
Applied Voltage Range:				Vdc
Feedback	20	V <sub>20</sub>	0 to +8.0	
Anode Current	9	V <sub>9</sub>	–2.0 to V <sub>CC</sub>	
All Other Pins	–	V <sub>i</sub>	0 to V <sub>CC</sub>	
ESD				V

**NOTE:** ESD data available upon request.

This document contains information on a new product. Specifications and information herein are subject to change without notice.

## CHROMA 4 VIDEO PROCESSOR

### SEMICONDUCTOR TECHNICAL DATA

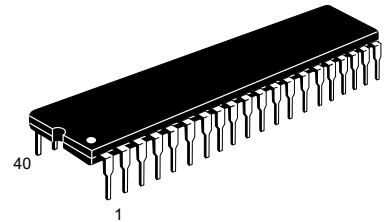

**P SUFFIX**  
PLASTIC PACKAGE  
CASE 711

### PIN CONNECTIONS

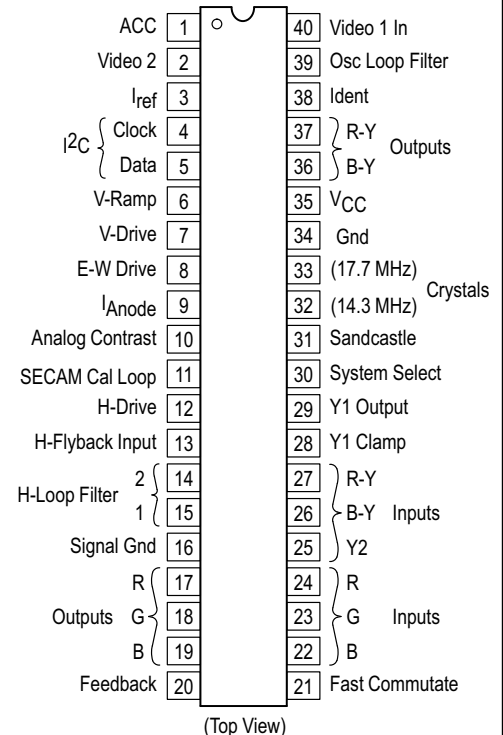

### ORDERING INFORMATION

Device	Operating Temperature Range	Package
MC44002P	T <sub>A</sub> = 0° to +70°C	Plastic DIP
MC44007P		Plastic DIP

# MC44002 MC44007

**MAXIMUM RATINGS** ( $T_A = 25^\circ\text{C}$ , unless otherwise noted.)

Rating	Pin	Symbol	Value	Unit
Human Body Model	-	-	$\pm 2000$	
Machine Model	-	-	$\pm 200$	

**NOTE:** ESD data available upon request.

## Simplified Block Diagram

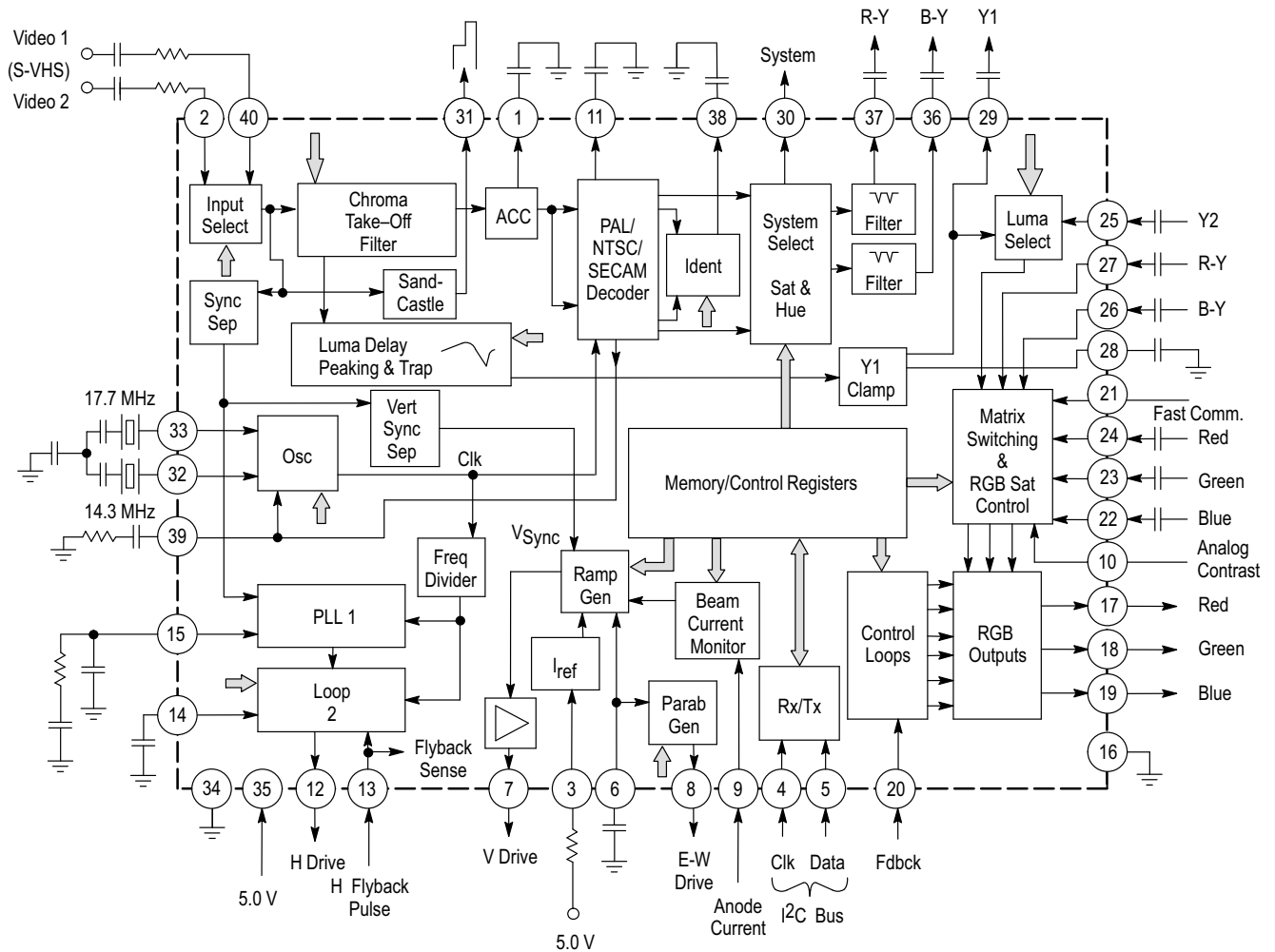

This device contains 6,245 active transistors.

**ELECTRICAL CHARACTERISTICS** ( $V_{CC} = 5.0\text{ Vdc}$ ,  $I_3 = 70\ \mu\text{A}$ ,  $T_A = 25^\circ\text{C}$ , unless otherwise noted.)

Characteristic	Pin	Min	Typ	Max	Unit
Supply Voltage	35	4.75	5.0	5.25	V
Operating Current	35	90	120	180	mA
Reference Current, Input Voltage	3	1.0	1.3	1.6	V
Thermal Resistance, Junction-to-Ambient	-	-	56	-	$^\circ\text{C/W}$

**NOTES:** Composite Video Input Signal Level = 1.0 Vpp  
 Black-to-White = 0. Vpp7, Syn-to-Black = 0.3 Vpp  
 PAL/NTSC = 75% color bars; Burst = 300 mVpp  
 SECAM = 75% color bars

Horizontal Timebase started (subaddress 00)  
 Vertical Breathing control set to 00; V9 = 0 V  
 All other analog controls set to midrange 32  
 Video Peaking "P1, P2, P3" bits high

## MC44002 MC44007

### TEST CONDITIONS (unless otherwise noted.)

$V_{CC} = 5.0\text{ V}$ $I_{ref} = 70\ \mu\text{A}$ $T_A = 25^\circ\text{C}$
Video Composite Input = 1.0 Vpp – Black-to-White = 0.7 Vpp – Black-to-Sync = 0.3 Vpp
Horizontal Timebase Started (Reg. 00)
Vertical Breathing Control Set to 00
Pin 9 = 0 V Pin 10 = 5.0 V
PAL/NTSC = 75% Color Bars –Burst = 300 mVpp SECAM = 75% Color Bars (MC44002 only)
All Analog Controls Set to Midpoint (32)
Luma Peaking at Min. (P1 – P3 = 111)

### Control Bits Setup

Name	Value	Function Status
V1/V2	1	Video Input 1 Selected
H EN	0	Horizontal Drive Enabled
BRI EN	1	“Bright” Sample “On”
HGAIN1	0	Horizontal Phase Detector Gain Reduced by 3 Enabled
YX EN	0	Luma Matrix Disabled
Y1 EN	1	Luma from Filters “On”
D EN	0	RGB Inputs Enabled
XS	0	Pin 33 Crystal Enabled
TEST	1	Outputs Sampled Once/Field
FSI	0	50 Hz Field Rate
T3	1	Low Pass Filter Enabled
VD1	1	4:3 Display Mode
2xFh	0	Horizontal Drive at 1xFh
NORM	0	Horizontal Reference Divider for 17.7 MHz
HGAIN2	1	Horizontal Phase Detector Gain Reduced by 2 Enabled
INTSEL	1	Long Vertical Time Constant
Y2 EN	0	External Luma Input “Off”
SSD	0	SECAM Mode Select Enabled
CALKIL	1	Horizontal Calibration Loop Enabled
BAI	1	Vertical Blanking for 625 Lines
S-VHS	1	Composite Video Input

# MC44002 MC44007

## ELECTRICAL CHARACTERISTICS

Parameter	Symbol	Pin	Min	Typ	Max	Unit
<b>BUS REQUIREMENTS</b>						
Maximum Output Low Voltage $I_{\text{sink}} = 1.0 \text{ mA}$ , Device in "Read" Mode	$V_{\text{OL(max)}}$	5	–	0.7	–	V
Maximum Sink Current $V_{\text{OL}} = 0.7 \text{ V}$ , Device in "Read" Mode	$I_{\text{sink(max)}}$	5	–	1.0	–	mA
Minimum Input High Voltage	$V_{\text{IH(min)}}$	5	–	3.0	–	V
Maximum Input Low Voltage	$V_{\text{IL(max)}}$	5	–	1.5	–	V
Maximum Rise Time Between $V_{\text{IH}}$ and $V_{\text{IL}}$ Levels	$t_{\text{r(max)}}$	4, 5	–	1.0	–	$\mu\text{s}$
SCL Clock Frequency	$f_{\text{SCL}}$	4	–	–	100	kHz

## HORIZONTAL TIMEBASE

Free-Running Frequency (Calibration Mode) 17.734475 MHz Crystal. "NORM" Bit = 0; "H EN" Bit = 1 (Horizontal Drive Disabled) 14.31818 MHz Crystal. "NORM" Bit = 1; "H EN" Bit = 1 (Horizontal Drive Disabled)	–	31	15.39 15.42	15.625 15.75	15.85 15.98	kHz
H-Loop 1 (Pin 15 Current Forced to $\pm 20 \mu\text{A}$ ) Minimum Frequency Maximum Frequency Frequency Range	–	12	13.85 16.05 –	14.25 16.55 2.3	14.65 17.05 –	kHz
VCO Control Gain	–	12, 15	1.9	2.4	2.9	kHz/V
Phase Detector Gain "HGAIN1" Bit = 1; "HGAIN2" Bit = 0	–	15	18	27	39	$\mu\text{A}/\mu\text{s}$
Phase Detector Gain Reduction Factor "HGAIN1" Bit Switched from 1 to 0 "HGAIN2" Bit Switched from 0 to 1	–	15	2.5 1.75	3.0 2.0	3.5 2.25	–
Line Drive Output Saturation Voltage $I_{\text{I2}} = 1.0 \text{ mA}$	–	12	–	0.25	0.5	V
Horizontal Drive Pulse Low Defined by Internal Counter, Deflection Transistor "Off", Period is 64 $\mu\text{s}$	–	12	–	27	–	$\mu\text{s}$
Horizontal Flyback Input Resistance $V_{\text{I3}} = 2.0 \text{ V}$	–	13	–	50	–	k $\Omega$
Horizontal Flyback Clamping Voltages $I_{\text{I3}} = 500 \mu\text{A}$ $I_{\text{I3}} = -50 \mu\text{A}$	–	13	– –	5.7 –0.5	– –	V
Horizontal Flyback Threshold Current Should be Externally Limited to 500 $\mu\text{A}$ Peak by an External Resistor	–	13	30	–	–	$\mu\text{A}$
Horizontal Phase Control Range Flyback Duration: 12 $\mu\text{s}$	–	12	8.0	–	12	$\mu\text{s}$
External Delay Compensation From Horizontal Drive to Center of Flyback Pulse. Flyback Duration: 12 $\mu\text{s}$	–	12, 13	6.0	–	18	$\mu\text{s}$

## VERTICAL TIMEBASE (All Values are Related to Pin 3 Reference Current)

Vertical Drive Amplitude (4:3 Display) (00) (32) (63) $C_6 = 82 \text{ nF}$ , Assuming Zero Tolerance Capacitance, "VDI" Set to "1"	–	7	1.15 1.55 1.95	1.33 1.75 2.18	1.5 1.95 2.4	V
Vertical Drive Amplitude Control Range (4:3 Display) $C_6 = 82 \text{ nF}$ , Assuming Zero Tolerance Capacitance, "VDI" Set to "1", Vertical Amplitude Varied from (00) to (63)	–	7	0.75	0.85	1.0	V

# MC44002 MC44007

## ELECTRICAL CHARACTERISTICS (continued)

Parameter	Symbol	Pin	Min	Typ	Max	Unit
<b>VERTICAL TIMEBASE</b> (All Values are Related to Pin 3 Reference Current)						
Ramp Amplitude Ratio Between 4:3 and 16:9 Display Modes Vertical Amplitude = (32)	–	7	0.7	0.8	0.9	–
Maximum Ramp Amplitude Change With 525/625 Mode Change	–	7	–	2.0	–	%
Vertical Ramp Low Voltage (4:3 Display) Pin 6 Voltage Set to 0 V, "VDI" Set to "1", Vertical Position = (00)	–	7	–	0.65	–	V
Vertical Ramp Low Voltage (16:9 Display) Pin 6 Voltage Set to 0 V, "VDI" Set to "0", Vertical Position = (00), Measured After 16:9 Holding Period	–	7	–	0.85	–	V
Vertical Ramp High Voltage Pin 6 Open, "VDI" Set to "0" or "1", Vertical Position = (63)	–	7	–	4.15	–	V
Vertical Ramp Position Control Range Versus Vertical Ramp Voltage at Vertical Position (32), Measured at $V_m$ , "VDI" Set to "0" or "1", Vertical Position Varied from (00) to (63)	–	7	±0.5	±0.75	±1.0	V
Vertical Ramp Clamping Duration ( $t_c$ ) Defined by Internal Counter	–	7	–	512	–	μs
Maximum Output Source Current	–	7	1.0	–	–	mA
Maximum Output Sink Current	–	7	200	–	–	μA
Vertical Linearity (00) (63)	–	7	– –	0.8 1.1	– –	–
Change in Ramp current as Pin 9 Current Varied from 0 to 6.4 μA Vertical Breathing Correction = (63) Vertical Breathing Correction = (00)	–	6	0.15 –	0.75 0	1.3 –	μA
Gain $V7/V6$	–	6, 7	0.9	0.95	1.0	V/V

### E–W CORRECTION ( $V6(b) = 0.2$ V, $V6(m) = 1.1$ V, $V6(e) = 2.0$ V)

Horizontal Amplitude (00) (63) Corner Correction = (00), Tilt = (32), Parabola Amplitude = (00), Measured at $T_m$ .	–	8	0 150	0.2 300	20 –	μA
Parabola Amplitude (00) (63) Corner Correction = (00), Horizontal Amplitude = (32), Tilt = (32), Measured at $T_b$ , $T_m$ and $T_e$ .	–	8	0 100	0.2 250	10 –	μA
Corner Correction (00) (63) Horizontal Amplitude = (63), Parabola Amplitude = (00), Tilt = (32), Measured at $T_b$ , $T_m$ and $T_e$ .	–	8	0 –	0.2 –150	10 –30	μA
Parabola Tilt (00) (63) Corner Correction = (00), Horizontal Amplitude = (32), Parabola Amplitude = (32), Measured at $T_b$ , $T_m$ and $T_e$ .	–	8	– –	1.9 –1.9	– –	–
E–W Drive Output Voltage	–	8	1.0	–	$V_{CC}$	V

# MC44002 MC44007

## ELECTRICAL CHARACTERISTICS (continued)

Parameter	Symbol	Pin	Min	Typ	Max	Unit
<b>E-W CORRECTION</b> (V6(b) = 0.2 V, V6(m) = 1.1 V, V6(e) = 2.0 V)						
E-W DACs Differential Non-Linearity Error At Minor Transitions: Steps 0-1: 1-2; 3-4; 7-8; 15-16. At Major Transition: Step 31-32	–	8	–1.0 –2.0	– –	1.0 1.0	LSB
<b>SYNC SEPARATOR</b>						
Sync Amplitude to Operate the Device From Black to Sync, Black Picture, Standard Timing Specifications on Sync Signal	–	2, 40 22, 23, 24, 25	100 –	– 160	– –	mV
Vertical Sync Separator Delay Time: $t_{\Delta}$ "INTSEL" = 0 "INTSEL" = 1 From Vertical Sync Pulse to Vertical Ramp Reset	–	2, 40	– –	36 68	– –	$\mu$ s
Vertical Sync Window	–	2, 40, 22, 23, 24, 25	448	–	740	Half Lines
<b>COMPOSITE VIDEO PROCESSING</b> (All measurements in NORMAL mode, unless otherwise noted.)						
Composite Video Input Amplitude Load Impedance 75 $\Omega$ , Less than 5% Distortion	–	2, 40	0.7	1.0	1.4	V <sub>pp</sub>
Video 1/Video 2 Input Crosstalk @ f = (2.0 MHz), Measured on Y1 Output	–	29	–	–	–40	dB
Variable Input LPF Cut-Off Frequency 17.7 MHz Crystal Selected 14.3 MHz Crystal Selected	–	29	– –	6.0 4.85	– –	MHz
Chroma Subcarrier Rejection PAL 4.43 MHz (17.7 MHz Crystal Selected) NTSC 3.58 MHz (14.3 MHz Crystal Selected) SECAM (F <sub>OR</sub> and F <sub>OB</sub> ) (17.7 MHz Crystal Selected)	–	29	25 25 18	30 30 20	– – –	dB
Y1 Output Resistance	–	29	–	–	300	$\Omega$
Y1 Bandwidth (–3.0 dB) PAL Minimum Peaking, "T3" Set to 1 (Input LPF "On") SECAM Minimum Peaking, "T3" Set to 0 (Input LPF "Off")	–	29	2.5 2.5	3.0 3.0	– –	MHz
Luma Peaking Range Measured at 3.0 MHz, 17.7 MHz Crystal Selected	–	29	6.0	8.5	–	dB
Luma Gain (@ 100 kHz)	–	2, 40, 29	0.9	1.1	1.3	V/V
Overshoot Peaking at Step 3 (100)	–	29	–	5.0	–	%
Source Impedance	–	2, 40	0	–	1.5	k $\Omega$
Luma Delay Range PAL/SECAM (17.7 MHz Crystal Selected) NTSC 3.58 (14.3 MHz Crystal Selected)	–	29	– –	280 350	– –	ns
Video In to Luma Out Delay Difference Between PAL and SECAM (MC44002 only) Luma Delay Minimum: (D1 D2 D3) = (0 0 0), Green to Magenta Transition, "T3" Set to 1 in PAL, to 0 in SECAM	–	29, 40	–	260	–	ns
<b>PAL/NTSC DECODER</b>						
Chroma Output Variation For a Burst Input Varied from 60 mV to 600 mV	–	36, 37	–	–	3.0	dB
Color Kill Attenuation Referred to Standard Color Video Input, Monochrome Mode Selected	–	36, 37	40	–	–	dB

## MC44002 MC44007

### ELECTRICAL CHARACTERISTICS (continued)

Parameter	Symbol	Pin	Min	Typ	Max	Unit
<b>PAL/NTSC DECODER</b>						
Color Difference Output Distortion @ 1.5 V Output Signal	–	36, 37	–	–	5.0	%
Residual Chroma Subcarrier Rejection PAL NTSC Referred to Video Input	–	36, 37	40 40	– –	– –	dB
Oscillator Pull-In Range PAL NTSC Referred to Nominal Subcarrier Frequency, with Ideal Xtal	–	32, 33	±350 ±400	– –	– –	Hz
R–Y, B–Y Channel Separation	–	36, 37	30	–	–	dB
B–Y/R–Y Amplitude Ratio At Standard Color Bars Signal	–	36, 37	–	1.3	–	V/V
B–Y/R–Y Amplitude Ratio Spread At Standard Color Bars Signal	–	36, 37	–2.0	–	2.0	dB
Minimum Burst Level for “ACC Active” Flag “On” Standard Set to PAL or NTSC, Increasing Burst Level Steps	–	2, 40	–	10	20	mVpp
Minimum Burst Level for “PAL Identified” Flag “On” Standard Set to PAL or NTSC, Increasing Burst Level Steps	–	2, 40	–	5.0	20	mVpp
Maximum Burst Level for “ACC Active” Flag “Off” Standard Set to PAL or NTSC, Decreasing Burst Level Steps	–	2, 40	–	5.0	–	mVpp
Maximum Burst Level for “PAL Identified” Flag “Off” Standard Set to PAL or NTSC, Decreasing Burst Level Steps	–	2, 40	–	1.0	–	mVpp
(B–Y) Color Difference Output Levels Relative to 75% Color Bars	–	36	0.7	1.1	1.5	V
Hue DAC Control Range Hue Control Register Varying from (00) to (63)	–	36, 37	±20	–	–	Deg
Chroma to Luma Delay PAL NTSC Measured on (B–Y) Output, Luma Delay Set to Minimum: (D1 D2 D3) = (0 0 0), Green to Magenta Transition, “T3” Set to 1	–	29, 36	– –	80 100	– –	ns
<b>DELAY LINE CONTROL SIGNALS</b>						
System Select PAL NTSC SECAM (MC44002 only) EXTERNAL	–	30	– 1.4 2.75 3.7	75 1.65 3.0 4.0	400 1.9 3.25 4.3	mV V V V
Sandcastle Level 1 Level 2 Level 3 Level 4 See Figure 4	–	31	3.7 2.75 1.3 –	4.0 2.95 1.55 75	4.3 3.15 1.8 –	V V V mV
Sandcastle t1 t2 See Figure 4, Values Defined by Internal Counter	–	31	5.0 4.0	6.0 5.0	7.0 6.0	μs

## MC44002 MC44007

### ELECTRICAL CHARACTERISTICS (continued)

Parameter	Symbol	Pin	Min	Typ	Max	Unit
<b>S-VHS VIDEO PROCESSING (S-VHS Set to 0, "T3" Set to 0)</b>						
Y1 Bandwidth Luma Peaking Set to Minimum	–	29	3.2	3.5	–	MHz
Minimum Burst Level for "ACC Active" Flag "On" Standard Set to PAL or NTSC, Increasing Burst Level Steps	–	2, 40	–	10	20	mVpp
Minimum Burst Level for "PAL Identified" Flag "On" Standard Set to PAL or NTSC, Increasing Burst Level Steps	–	2, 40	–	5.0	20	mVpp
Maximum Burst Level for "ACC Active" Flag "Off" Standard Set to PAL or NTSC, Decreasing Burst Level Steps	–	2, 40	–	5.0	–	mVpp
Maximum Burst Level for "PAL Identified" Flag "Off" Standard Set to PAL or NTSC, Decreasing Burst Level Steps	–	2, 40	–	1.0	–	mVpp
Video In to Luma Out Delay Difference Between S-VHS and Normal Mode Luma Delay Minimum in Normal Mode, Set to Step 6 in S-VHS Mode, Green to Magenta Transition, "T3" Set to 1 in Normal Mode, to 0 in S-VHS Mode	–	2, 40, 29	–	310	–	ns
Chroma to Luma Delay Difference Between S-VHS and Normal Mode Measured on (B-Y) Output, Luma Delay Minimum in Normal Mode, Set to Step 6 in S-VHS Mode, Green to Magenta Transition, "T3" Set to 1 in Normal Mode, to 0 in S-VHS Mode	–	29, 36, 2, 40	–	60	–	ns
<b>SECAM DECODER (MC44002 ONLY)</b>						
Minimum Subcarrier Level for "SECAM Identified" Flag Measured at $f_0R$	–	2, 40	–	10	20	mVpp
Color Kill Attenuation Monochrome Mode Selected Referred to Color Difference Output Signal with SECAM Selected and Identified	–	36, 37	40	50	–	dB
Color Difference Zero Level Error Relative to 75% Color Bars, Difference Between Signal Measured at t1 and Active Black Level (Black Bar)	–	36, 37	–	±1.0	±3.0	%
Color Difference Output Distortion Subcarrier Level at $f_0R = 20\text{--}400\text{ mV @ }1.5\text{ V}$ Output Signal	–	36, 37	–	–	5.0	%
Transient Response (B-Y) (R-Y) Generator Rise Time – 600 ns (B-Y), Green to Magenta Transition, Measured Between 10% and 90% Levels	–	36 37	– –	650 750	800 900	ns
B-Y/R-Y Amplitude Ratio Ratio Spread Relative to 75% Color Bars	–	36, 37	– –2.0	1.3 –	– 2.0	V/V dB
Residual Carrier and Harmonics (4.0 to 13.5 MHz) At Standard Color Bars Signal	–	36, 37	–	–	1.0	%
(B-Y) Color Difference Output Levels Relative to 75% Color Bars	–	36	–	1.1	–	V
PAL/SECAM Color Difference Ratio Nominal Input Signals	–	36	0.8	1.0	1.2	–

# MC44002 MC44007

## ELECTRICAL CHARACTERISTICS (continued)

Parameter	Symbol	Pin	Min	Typ	Max	Unit
<b>SECAM DECODER (MC44002 ONLY)</b>						
Chroma to Luma Delay Luma Delay Set to Minimum: (D1 D2 D3) = (0 0 0), Green to Magenta Transition, "T3" Set to 0	–	29, 36	–	420	–	ns
Patterning Full Screen 75% Color Frequency, 500 kHz Low Pass Filter, Relative to Black to Color Output Signal	–	36	–	–	5.0	%
Line to Line Luma Levels Difference Full Screen 75% Yellow Color Frequency, Relative to Black to Yellow Output Signal	–	29	–	–	1.5	%
Chroma to Luma Delay Difference Between PAL and SECAM Measured on (B–Y) Output, Luma Delay Set to Minimum: (D1 D2 D3) = (0 0 0), Green to Magenta Transition, "T3" Set to 0 in SECAM, to 1 in PAL	–	29, 36	–	340	–	ns
<b>COLOR DIFFERENCE STAGES</b>						
RGB Input Amplitude Black to Peak (Less than 5% Distortion at RGB Outputs)	–	22, 23, 24	500	700	1000	mVpp
Fast Commutate Low Level High Level	–	21	– 1.0	– –	0.5 –	V
Y2 Input Amplitude (Less than 5% Distortion at RGB Outputs)	–	25	0.7	1.0	1.4	Vpp
Color Difference Input Amplitude (Less than 5% Distortion at RGB Outputs)	–	26, 27	–	–	1.8	Vpp
Y2/Y1 Crosstalk Measured at RGB Outputs, Measured at f = (2.0 MHz)	–	25, 29	–	–40	–30	dB
RGB to Y Crosstalk Measured at RGB Outputs, Measured at f = (2.0 MHz)	–	22, 23, 24, 25, 29	–	–40	–30	dB
RGB Transconductance Bandwidth (@ –1.0 dB)	–	24, 17, 23, 18, 22, 19	6.5	–	–	MHz
Gain Reduction in ACL Mode Pin 10 Voltage Varying from 0 to 5.0 v	–	10, 17, 18, 19	–	12.5	–	dB
Gain Reduction Sensitivity in ACL Mode Pin 10 Voltage Varying from 2.0 to 2.5 V	–	10, 17, 18, 19	–	20	–	dB/V
Demodulation Angles and Amplitudes	–	–	–	–	–	Deg
Mode A	Rm		–	0.562	–	
	Ra		–	90	–	
	Gm		–	0.344	–	
	Ga		–	237	–	
Mode B	Rm		–	0.9	–	
	Ra		–	100	–	
	Gm		–	0.3	–	
	Ga		–	236	–	
Mode C	Rm		–	0.9	–	
	Ra		–	106	–	
	Gm		–	0.3	–	
	Ga		–	240	–	
Mode D	Rm		–	0.91	–	
	Ra		–	106	–	
	Gm		–	0.31	–	
	Ga		–	246	–	
Definitions: Rm/Gm = Module, Ra/Ga = Argument						

# MC44002 MC44007

## ELECTRICAL CHARACTERISTICS (continued)

Parameter	Symbol	Pin	Min	Typ	Max	Unit
<b>RGB OUTPUT STAGES</b>						
Low Dark Sample Output Current Red Green Blue Dark Sample Cathode Current 5.0 to 15 $\mu$ A, DC DAC Set to Full Scale, See Figure 1	–	17, 18, 19	–	–	3.15	mA
High Dark Sample Output Current Red Green Blue Dark Sample Cathode Current 5.0 to 15 $\mu$ A, DC DAC Set to Zero, See Figure 1	–	17, 18, 19	3.95	–	–	mA
Blanking Output Current	–	17, 18, 19	6.0	–	–	mA
Maximum Y to RGB Output Transconductance Gain DAC Set to Full Scale	–	17, 18, 19	6.0	7.0	8.0	mA/V
Brightness (00) (63) Wrt Dark Sample Cathode Voltage, High Voltage Output Stage Transimpedance 39 k $\Omega$ , Dark Sample Cathode Current 15 $\mu$ A, Dark Sample Cathode Voltage 140 V	–	–	–	30 –20	–	V
RGB Dark Sample Current Intensity Range RGB Intensity DACs Varying from (00) to (63)	–	20	15	20	–	dB
Bright to Dark Sample Current Ratio	–	20	8.0	9.5	11	$\mu$ A/ $\mu$ A
Leakage Loop Sink Current Source Current	–	20	20 5.0	– –	– –	$\mu$ A
Average Beam Current Detection Level Excess Flag Overload Flag	–	9	0.9 –1.3	1.0 –1.2	1.1 –1.1	V
Peak Beam Current Detection Level	–	20	6.5	6.8	7.1	V

Figure 1. Example of Output Circuitry

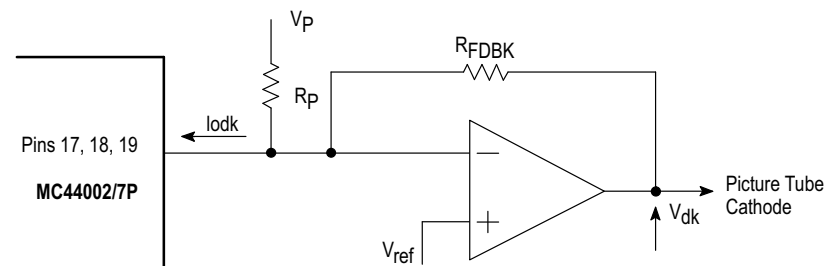

$V_p$ ,  $V_{ref}$ ,  $R_{FDBK}$  and  $R_p$  values will determine the exact operating point.

For example, let us take:

$$V_p = 5.0 \text{ V} \quad R_{FDBK} = 39 \text{ k}\Omega$$

$$V_{ref} = 3.6 \text{ V}$$

$$R_p = 6.8 \text{ k}\Omega$$

The formula giving the Dark Cathode Voltage with above circuit is:  $V_{dk} = V_{ref} + R_{FDBK} * (V_{ref} - V_p + I_{odk} * R_p) / R_p$

With above application, component values and  $I_{odk}$  specifications, all 3 cathodes on all devices will always have a range of at least 120 V to 150 V.

By changing the values of  $V_p$ ,  $V_{ref}$  and  $R_p$ , the cathode voltage range may be shifted up or down as required.

# MC44002 MC44007

Figure 2. Vertical Waveforms

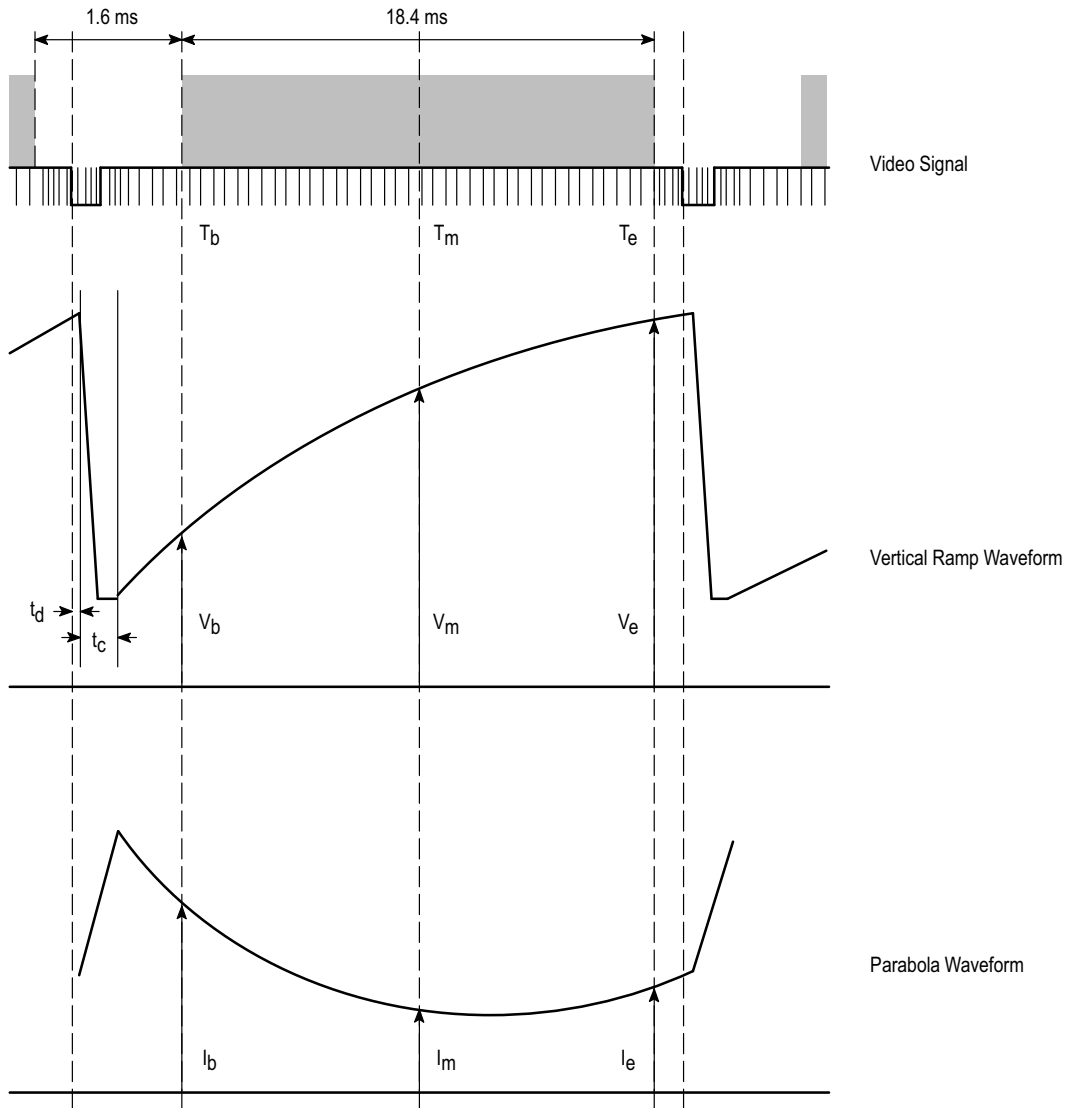
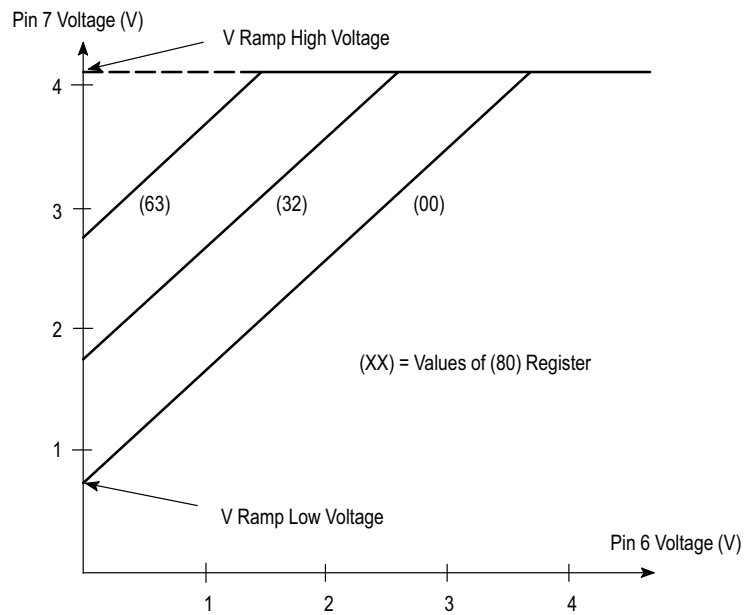

Figure 3. Vertical Ramp Positions (V7 versus V6)



## MC44002 MC44007

### Definitions

$$\text{Parabola Amplitude} = \frac{(i_b + i_e)}{2} - i_m$$

$$\text{Parabola Tilt} = \frac{(i_e - i_b)}{\text{Parabola Amplitude}}$$

$$\text{Horizontal Amplitude} = i_m$$

Corner correction is calculated in the same way as Parabola Amplitude.

$$\text{Vertical Amplitude} = V_e - V_b$$

$$\text{Vertical Linearity} = \frac{(V_e - V_m)}{V_m - V_b}$$

Figure 4. Sandcastle Output (Pin 31)

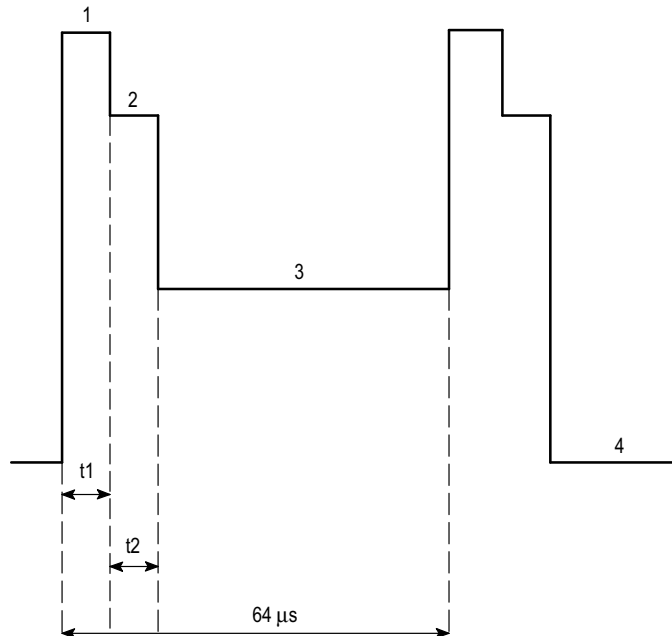

### GENERAL DESCRIPTION OF THE CHROMA 4 SYSTEM

Figure 5 shows a simplified block diagram representation of the basic system using the MC44002/7 and its companion device the MC44140 chroma delay line. The MC44002/7 has been designed to carry out all the processing of video signals, display controls and timebase functions. There are two video inputs which can be used for normal composite video or separate Y and C inputs. In either case, the inputs are interchangeable and selection is made via the I<sup>2</sup>C bus. The video is decoded within the MC44002/7 and involves

separation, filtering, delay of the luminance part of the signal and demodulation of the chroma into color difference signals. The luminance (called Y1) together with the demodulated R-Y and B-Y are all then brought out from the IC. The color difference signals then enter the MC44140 which performs color correction in PAL and the delay line function in SECAM. Corrected color difference signals then re-enter the MC44002/7.

# MC44002 MC44007

Figure 5. Connection to TV Chassis

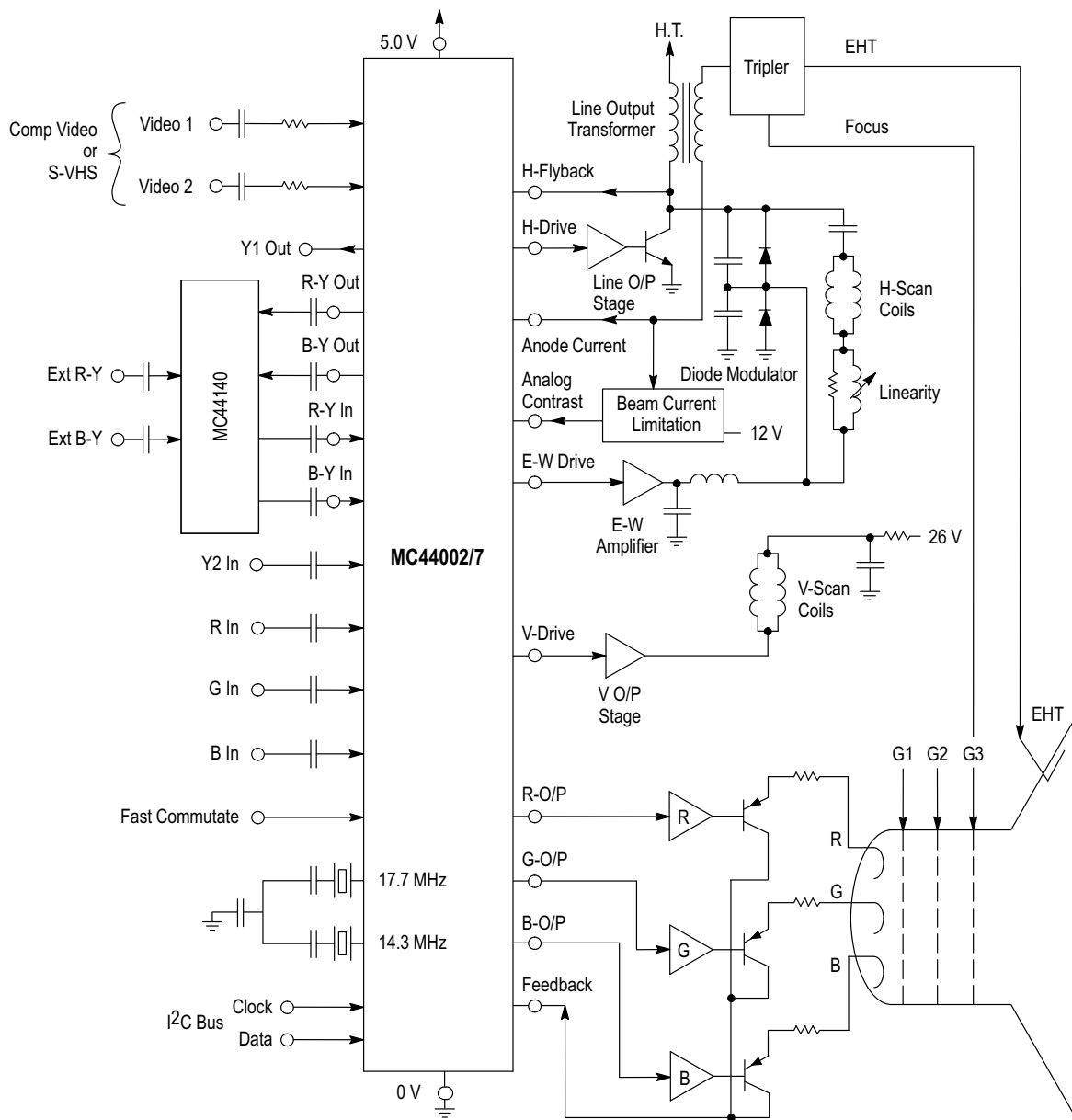

The next stage is called the color difference stage where a number of control functions are carried out together with matrixing of the components to derive RGB signals. At this point a number of auxiliary signals may also be switched in, again all under MCU control. External RGB (text) and Fast Commutate enter here; also an external luminance (Y2) may be used instead of Y1. External R-Y and B-Y are switched in via the delay line circuit to save pins on the main device. The Y2 and External R-Y, B-Y will obviously be of considerable benefit from the system point of view for use with external decoders.

The final stage of video processing is the RGB outputs which drive the high voltage amplifiers connected to the tube cathodes. These outputs are controlled by a sophisticated digital servo-loop which is maintained and stabilized by a sequentially sampled beam current feedback system. Automatic gray scale control is featured as a part of this system.

Both horizontal and vertical timebases are incorporated into the MC44002/7 and control is via the I<sup>2</sup>C bus. The

horizontal timebase employs a dual loop system of a PLL and variable phase shifter, and the vertical uses a countdown system. For the vertical, a field rate sawtooth is available which is used to drive an external power amplifier with flyback generator (usually a single IC). The line output consists of a pulse which drives a conventional line output stage in the normal way. The line flyback pulse is sensed and used by the second loop for horizontal phase shift.

Where E-W correction is required, a parabola waveform is available for this which, with the addition of a power amplifier, can be used with a diode modulator type line output stage for dynamic width and E-W control. The bottom of the EHT overwinding is returned to the MC44002/7 and is used for anode current monitoring.

Fast beam current limitation is also made possible by the use of an analog contrast control.

A much more detailed description of each stage of the MC44002/7 will be found in the next section. Information on the delay line is to be found in its own data sheet.

# MC44002 MC44007

## Introduction

The following information describes the basic operation of the MC44002/7 IC together with the MC44140 chroma delay line. The MC44002/7 is a highly advanced circuit which performs all the video processing, timebase and display functions needed for a modern color TV. The device employs analog circuitry but with the difference that all its advanced features are under processor control, enabling external filtering and potentiometer adjustments to be removed completely. Sophisticated feedback control techniques have been used throughout the design to ensure stable operating conditions and the absence of drift with age.

The IC described herein is one of a new generation of TV circuits, which make use of a serial data bus to carry out control functions. Its revolutionary design concept permits a level of integration and degree of flexibility never achieved before. The MC44002/7 consists of a single bipolar VLSI chip which uses a high density, high frequency, low voltage process called MOSAIC 1.5. Contained within this single 40 pin package is all the circuitry needed for the video signal processing, horizontal and vertical timebases and CRT display control for today's color TV. Furthermore, all the user controls and manufacturer's set-up adjustments are under the control of the processor I<sup>2</sup>C bus, eliminating the need for potentiometer controls. The MC44002/7 offers an enormous variety of different options configurable in software, to cater to virtually any video standard or circumstance commonly met. The decoder section offers full multistandard capability, able to handle PAL, SECAM (MC44002 only) and NTSC standards with 4 matrix modes available. Practically all the filtering is carried out onboard the IC by means of sampled data filters, and requires no external components or adjustment.

## Digital Interface

One of the most important features of MC44002/7 is the use of processor control to replace external potentiometer and filter adjustments. Great flexibility is possible using processor control, as each user can configure the software to suit their individual application. The circuit operates on a bidirectional serial data bus, based on the well known I<sup>2</sup>C bus. This system is rapidly becoming a world standard for the control of consumer equipment.

## I<sup>2</sup>C Bus

It is not within the scope of this data sheet to describe in detail the functioning of the I<sup>2</sup>C bus. Basically, the I<sup>2</sup>C bus is a two-wire bidirectional system consisting of a clock and a serial data stream. The write cycle consists of 3 bytes of data and 3 acknowledge bits. The first byte is the Chip Address, the second the Sub-address to identify the location in the memory, and the third byte is the data. When the address' Read/Write bit is high, the second and third bytes are used to transmit status flags back to the MCU.

Figure 6 shows a block diagram of the MC44002/7 Bus Interface/Decoder. To begin with, the start bit is recognized by means of the data going low during CLK high. This causes the Counter and all the latches to be reset. For a write operation, the Write address (\$88) is read into the Shift Register. If the correct address is identified, the Chip Address Latch is set and at CLK 9 an acknowledge is sent.

The second byte is now read into the Shift Register and is used to select the Sub-address. At CLK 18 a Sub-address Enable is sent to the memory to allow the Data in the register to be changed. Also, at CLK 18 another acknowledge is sent.

The third byte is now read into the Shift Register and the Data bussed into the memory. The Data in the Sub-address location already selected is then altered. A third acknowledge is sent at CLK 27 to complete the cycle.

A Read address (\$89) indicates that the MCU wants to read the MC44002/7 status flags. In this instance, the Read/Write Latch is set, causing the Memory Enable and Subaddress Enable to be inhibited, and the flags to be written onto the data line. Two of the status flags are permanently wired one-high and one-low (O.K. and Fault), to provide a check on the communication medium between the MC44002/7 and the MCU.

At start-up the Counter is automatically reset and the Data for each Sub-address is read in from the MCU. Only after the entire memory contents have been transmitted, is Data 00 sent to register 00 to start the Horizontal Drive.

The MC44002/7 needs the full 27 clock cycles, or a stop condition, to properly release the I<sup>2</sup>C bus.

Figure 6. I<sup>2</sup>C Bus Interface and Decoder

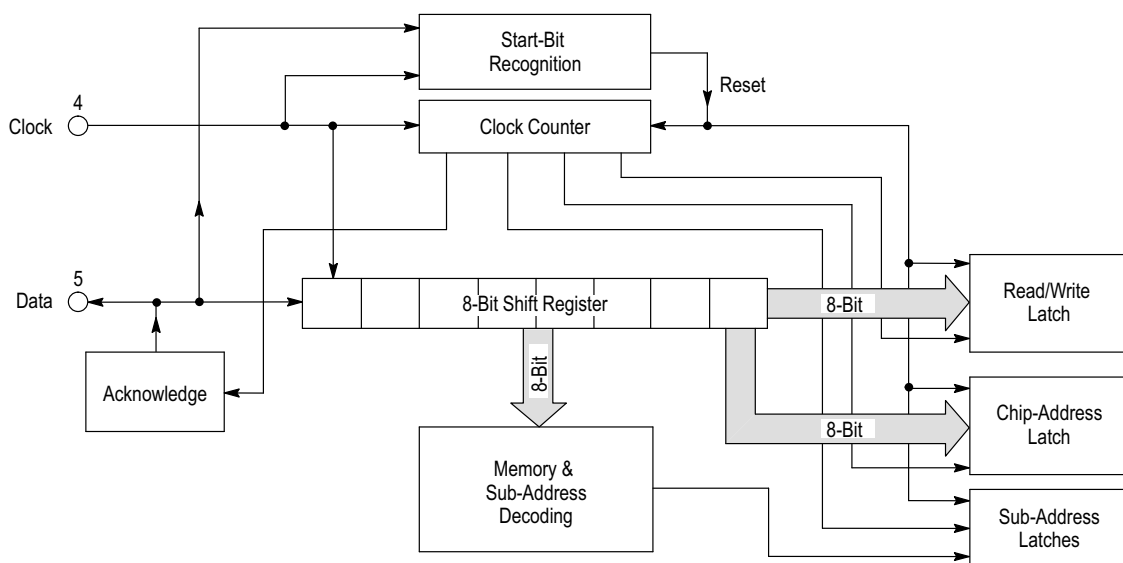
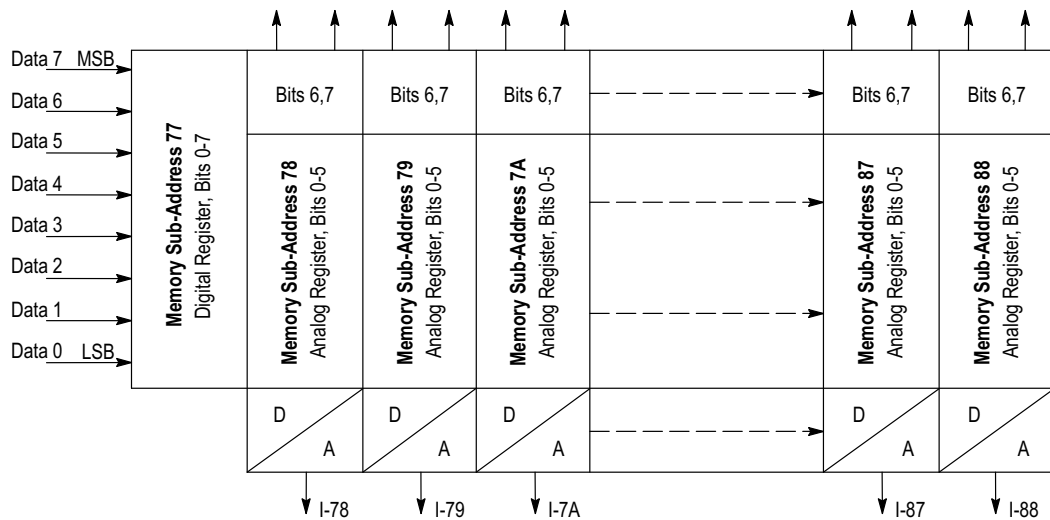

Figure 7. MC44002/7 Memory Map



### Memory

Figure 7 shows a diagram of the MC44002/7 Memory Map. It has 18 bytes of memory which are located at hex sub-addresses 77 to 88. Sub-address 77 is used to set up the vertical timebase mode of the IC and for S-VHS switching, and consists of 8 separate data bits. The remaining 17 bytes use the least significant 6-bits as an analog control register. The contents of each are D/A converted, providing an analog control current which is distributed to the appropriate part of the circuit. Bits 6 and 7 are used singularly for switching control functions.

### Chroma Decoder

The main function of this section is to decode the incoming composite video, which may be in any of the PAL, NTSC or SECAM (MC44002 only) Standards, and to retrieve the luminance and color difference signals. In addition, the signal filtering and luma delay line functions are carried out in this section by means of sampled data filters.

The entire decoder section operates in sampled data mode using clocks generated by external crystals. The oscillator, which is phase-locked in the usual way for PAL/NTSC modes, provides the clock function for the whole circuit. The crystals are selected by the MCU by means of a control bit (XS). Only crystals appropriate to the standards which are going to be received need to be fitted. A 17.7 MHz crystal (4x PAL subcarrier) is used for PAL and SECAM systems (50 Hz, 625 lines); and 14.3 MHz (4x NTSC subcarrier) for the NTSC system (60 Hz, 525 lines). Nearly all the filters, together with the luma delay line and peaking, have been integrated, requiring no external components or any adjustment. The filter characteristics are entirely determined by the clocks and by capacitor ratios, and are thus completely independent of variations in the manufacturing process. The PAL/NTSC subcarrier PLL and ACC loop filters have not been integrated in order to facilitate testing. These filters consist of fixed external components.

Figure 8 is a block diagram of the main features of the chroma decoder. Selection is first made between the Video 1 and Video 2 inputs. These may be either normal composite video or separate luma and chroma which may enter the IC at either pin. Commands from the MCU are used to route the signals through the appropriate delay and filter sections.

In PAL/NTSC, a variable low pass filter, which can be software bypassed (control bit T3), is then used to compensate for IF filtering and the Q of the external sound traps. Filter response is controlled by means of control bits T1 and T2. It is not recommended to use this filter in SECAM or in S-VHS, as luma-chroma delays will not be optimized. Next, the video enters the luma path. The PAL/NTSC or SECAM chroma signals are separated out by transversal high pass filters. In SECAM mode, the chroma trap frequency is dynamically steered to follow the instantaneous frequency of the chroma.

Then, another transversal filter provides luma peaking, which is also active in S-VHS mode. The high frequency luma may be peaked (at about 3.0 MHz with the 17.7 MHz crystal, and 2.4 MHz with the 14.3 MHz crystal) in 7 steps up to a maximum of 8.5 dB, by a control word from the MCU.

Another control word is used to trim the delay in the luma channel. Five steps of 56 ns (70 ns with the 14.3 MHz crystal) are possible, giving a total programmable delay of 280 ns. Steps 6 and 7 are used in S-VHS mode. The resulting processed luma signal then proceeds to the color difference section after being low-pass filtered by an active filter to remove components of the crystal frequency, and twice that frequency. The luma component (Y1) is made available at Pin 29 for use with auxiliary external functions, as well as testing.

When in the S-VHS mode, the S-VHS control bit controls the signal paths. The luma signal bypasses the first section of the luma channel, which contains the chroma trap. The S-VHS chroma is passed directly to the PAL/NTSC decoder without further filtering.

As all the delay and filter responses are determined by the crystal, they automatically commute to the new standard when the crystal is changed over. Thus, when the 14.3 MHz clock is being used, the chroma trap moves to 3.58 MHz.

The filtered PAL/NTSC and SECAM chroma signals are decoded by their respective circuits. The PAL/NTSC decoder employs a conventional design, using ACC action for gain control and the common double balanced multipliers to retrieve the color difference signals. The SECAM decoder is discussed in a separate subsection.

Figure 8. Chroma Decoder

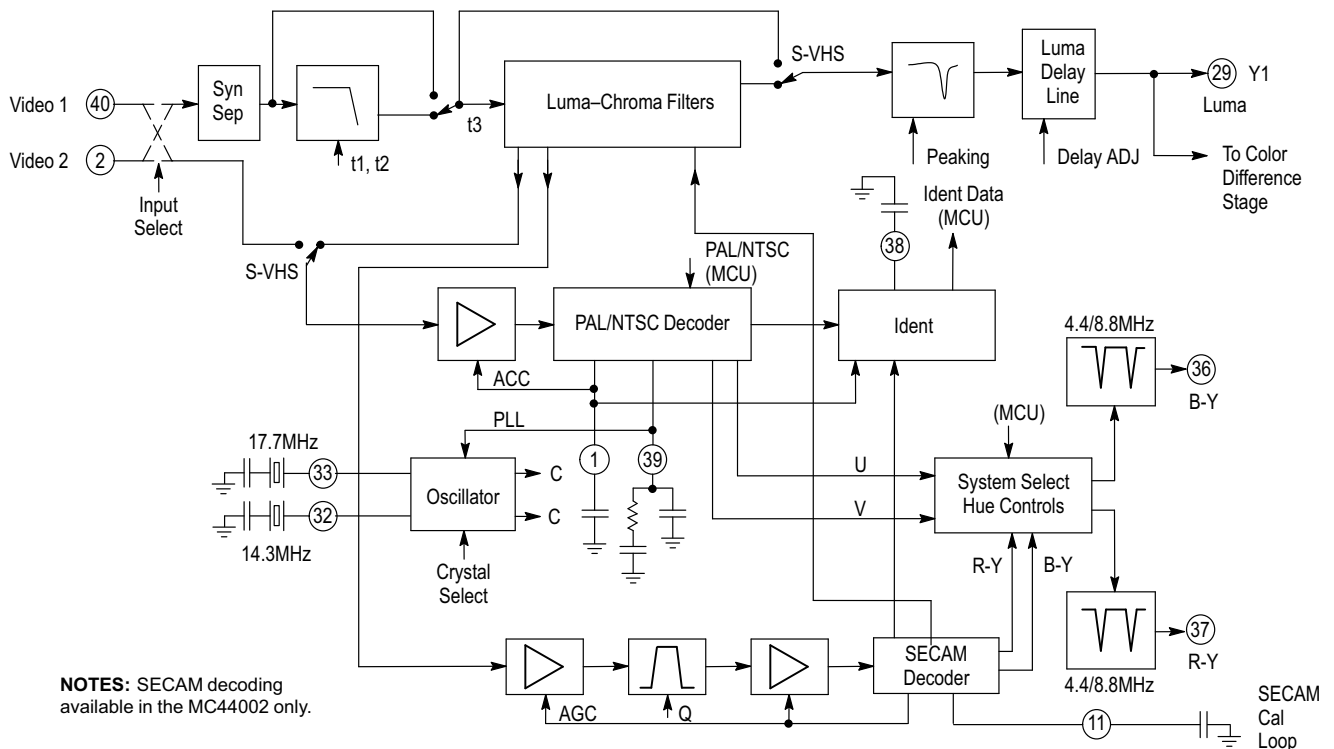

The actual decision as to a signal's identity is made by the MCU based on data provided by 3 flags returned to it, namely: ACC Active, PAL Identified, and SECAM Identified.

Control bits SSA-SSD must be sent to set the decoder to the correct standard.

This allows a maximum of flexibility, since the software may be written to accommodate many different sets of circumstances. For example, channel information could be taken into account if certain channels always carry signals in the same standard. Alternatively, if one standard is never going to be received, the software can be adapted to this circumstance. If none of the flags are on, color killing can be implemented by the MCU. This occurs if the net Ident Signal is too low, or if the ACC circuit is inactive due to too low a signal level.

The demodulated color difference signals now enter the Hue control section, where selection is made between PAL/NTSC and SECAM outputs. The Hue control is simply realized by altering the amplitudes of both color difference signals together. Hue control is only a requirement in NTSC mode and would not normally be used for other standards. The function is usually carried out prior to demodulation of the chroma by shifting the phase of the subcarrier reference, causing decoding to take place along different axes. In the MC44002/7, Hue control is performed on the already demodulated color difference signals. A proportion of the R-Y signal is added or subtracted to the B-Y signal and vice-versa. This has the same effect as altering the reference phase. If desired, the MC44002/7 can apply the Hue control to simple PAL signals.

After manipulation by the Saturation and Hue controls, the color difference signals are finally filtered to reduce any remaining subcarrier and multiplier products. Before leaving the chip at Pins 36 and 37, the signals are blanked during line

and frame intervals. The 64  $\mu$ s chroma delay line is carried out by a companion device, the MC44140.

#### SECAM Decoder (MC44002 only)

The SECAM signal from the high-pass filter enters tightly controlled AGC amplifiers wrapped around a cloche filter which is a sampled recursive type, with the AGC derived from a signal squarer. Next, the signal is blanked during the calibration gate period and a reference 4.43 MHz is inserted during this time. The SECAM signal is then passed through a limiter.

The frequency demodulator function is carried out by a frequency-locked-loop (F.L.L.). This consists of three components: a tracking filter, a phase detector and a loop filter. The center frequency of the tracking filter depends on three factors: internal R-C product, ADJUST voltage, and TUNING voltage. The tracking filter is dynamically tuned by the TUNING feedback from the loop-filter forming the F.L.L. The ADJUST control calibrates the F.L.L. and compensates for variations in the R-C product. After the F.L.L., the color difference signals are passed to another block where several functions are carried out. The signals are de-emphasized and outputs are provided to the Ident section. Another function of this section is to generate the I<sub>COMP</sub> signal used for calibrating the F.L.L. This signal is blanked during the H-IG period to ensure that (R-Y) and (B-Y) output signals have a clean dc level for clamping purposes.

In addition, components are added to compensate for the R-C product, and tuning offsets are introduced during the active lines for F0R/F0B.

Calibration of the F.L.L. takes place during every field blanking interval, starting from field retrace and ending just before the SECAM vertical Ident sequence (bottles). The calibration current I<sub>CAL</sub> is derived from I<sub>COMP</sub> during the

## MC44002 MC44007

calibration gate (CAL) and integrated by an external capacitor on Pin 11. The resulting voltage  $V_{EXT}$  is then transformed to generate the ADJUST control voltage removing from the loop range most of the variations due to internal RC products and temperature.

### Color Difference Stages

This stage accepts luminance and color difference signals, together with external R,G,B and Fast Commutation inputs and carries out various functions on them, including clamping, blanking, switching and matrixing. The outputs, consisting of processed R,G,B signals, are then passed to the Auto Gray Scale section.

A block diagram of this stage is shown in Figure 10. The Y2, R-Y, B-Y together with R, G and B are all external inputs to the chip. The Y1 signal comes from the decoder section. Each of the signals is back-porch clamped and then blanked. The Y2 and R,G,B inputs have their own simple sync separators, the output from which may be used as the primary synchronization for the chip by means of commands from the MCU.

The Fast Commutation is an active high input used to drive a high speed switch; for switching between the Y and color difference inputs and the R,G,B (text) inputs.

After blanking, the Y1 and Y2 channels go to the Luma Selector which is controlled by means of 2 bits from the MCU.

From here the selected luma signal goes to the RGB matrix. The two color difference signals pass through the saturation control. From here they go to a matrix in which G-Y is generated from the R-Y and B-Y, and lastly, to another matrix where Y is added to the three color difference signals to derive R,G,B.

Control bits (via the I<sup>2</sup>C bus) allow the matrix coefficients to be adjusted in order to suit different requirements, particularly in NTSC. Table 1 shows the theoretical demodulation angles and amplitudes and the corresponding matrix coefficient values for each of the 4 selectable modes. (The A mode corresponds to the standard PAL/SECAM/NTSC mode). Although primarily intended for NTSC, this feature can also act on PAL/SECAM or external RGB signals.

The R,G,B inputs may take one of two different paths. They may either go straight to the output without further processing, or via a separate matrix and the saturation control. The path taken is controlled in software. When the latter route is selected, the R,G,B signals undergo a matrix operation to derive Y. From this, R-Y and B-Y are easily derived by subtraction from R and B; the derived color difference signals are then subjected to saturation control. This extra circuitry allows another feature to be added to the TV set, namely the ability to adjust the color saturation of the RGB inputs. After the saturation control the derived signals are processed as before.

Table 1. Matrix Modes Coefficients

	A	B	C	C
RR	1.0	1.577	1.539	1.556
RB	0	-0.156	-0.248	-0.251
GR	-0.513	-0.443	-0.462	-0.504
GB	-0.187	-0.168	-0.150	-0.125
BB	1.0	1.0	1.0	1.0
BR	0	0	0	0
Rm	0.562	0.9	0.9	0.91
Gm	0.344	0.3	0.3	0.31
Ra	90	100	106	106
Ga	237	236	240	246

NOTE: BB = Gain of  $(B_{out}/(B-Y)_{in}) = 1$  (reference). BR = Gain of  $(B_{out}/(R-Y)_{in}) = 0$  (theoretically).

Figure 9. SECAM Decoder (MC44002 only)

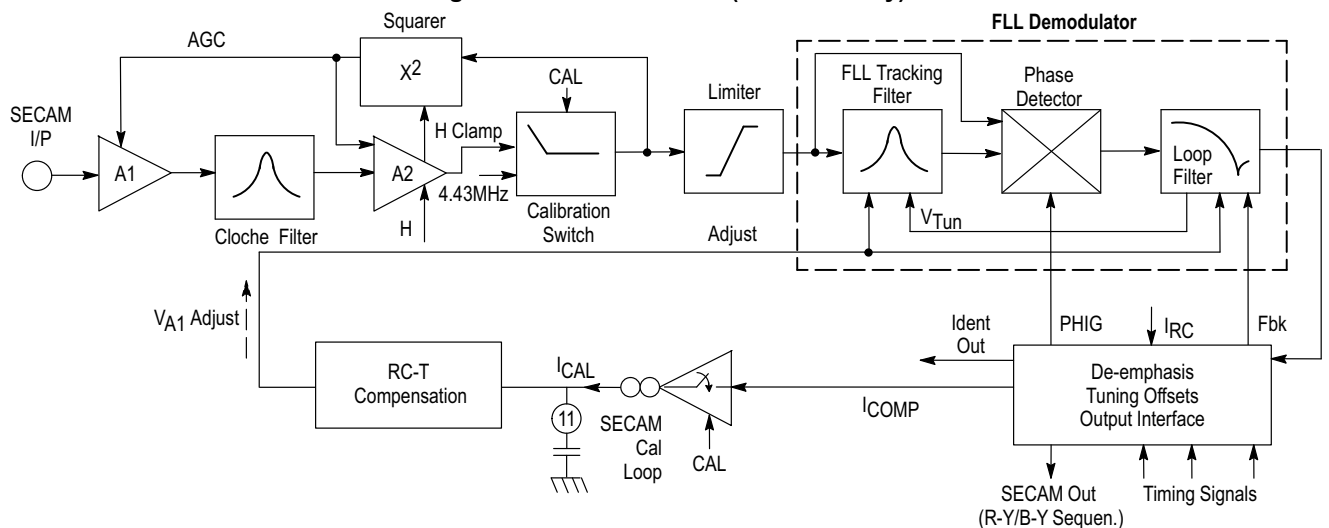

# MC44002 MC44007

Figure 10. Color Difference Stages

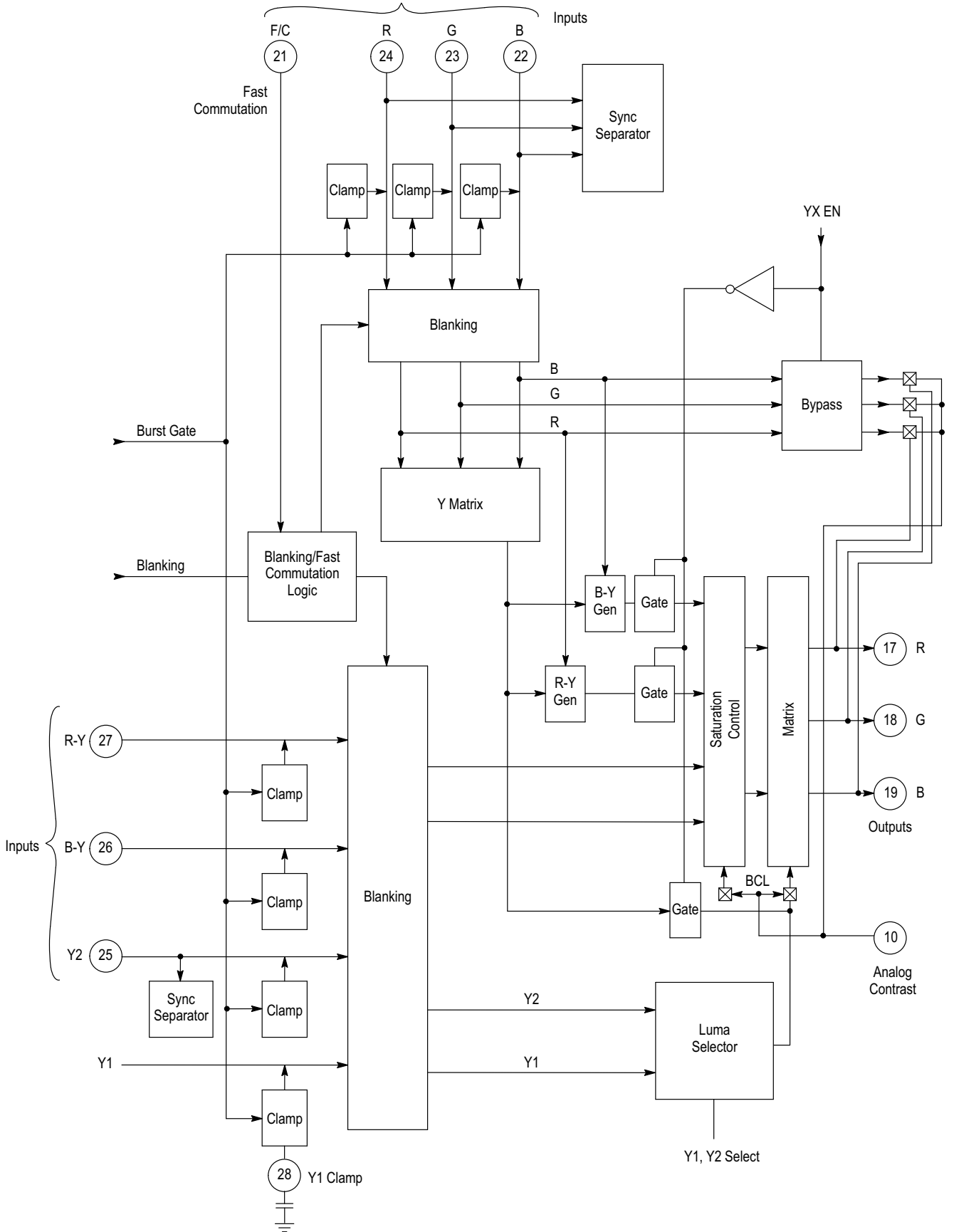

In order to implement automatic beam current limiting (BCL), the possibility of fast contrast reduction has been added. For normal operation, the Contrast control is achieved by auto grey scale output loops and is I<sup>2</sup>C bus controlled (see Section 4). In the case of excess beam current, this control is not fast enough to protect the tube and power supply stages. It is now possible, by acting on the Pin 10 voltage, to reduce the contrast about 12 dB by reducing the luma gain and saturation. In the case of direct RGB mode, the RGB gains are also reduced.

Figure 11. Typical Contrast Reduction

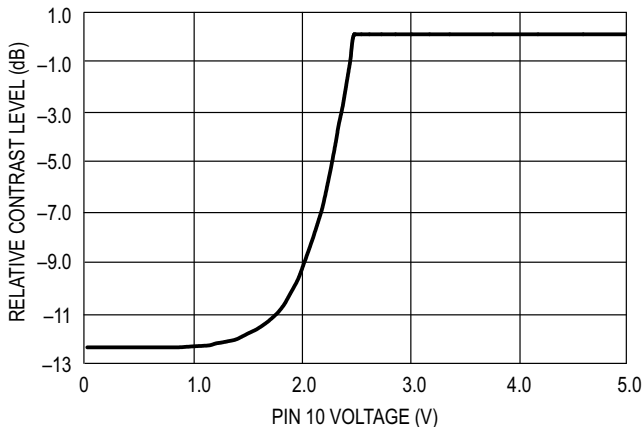
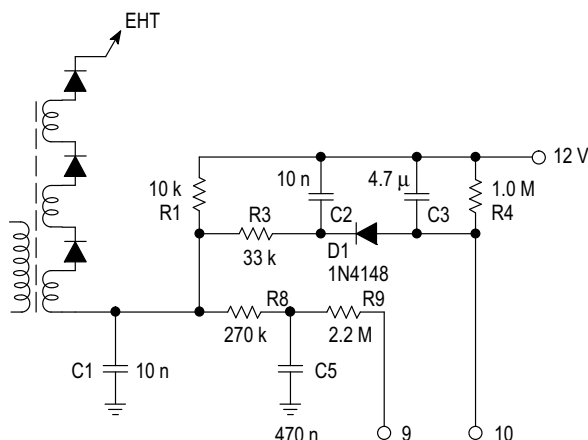

Figure 11 is showing the typical analog CONTRAST reduction possible as a function of the voltage on Pin 10. Two solutions are possible for obtaining the BCL function:

**1st solution:** A measure of the average and/or peak beam current is applied to Pin 10, which causes a reduction of the RGB drive levels to the high voltage video amplifiers. In this case, no software control is required, but variations in color balance and saturation may be observed. A typical application is shown in Figure 12.

**2nd solution:** The beam current flags are read and acted on by the MCU, which reduces the I<sup>2</sup>C bus CONTRAST control to maintain the average beam current below the desired level. In the case of rapid and extreme beam current changes (black to white picture at high contrast level), the circuit of Figure 12 may be used as a fast aging protection while the MCU is reducing the CONTRAST through I<sup>2</sup>C bus. The average of this method is to make any color balance/saturation variation only transient.

Figure 12. Automatic Beam Current Limiter Application



Auto Gray Scale Control Loops

This section supplies current drives to the RGB cathode amplifiers and receives a signal feedback from them, proportional to the combined cathode currents. The current feedback is used to establish a set of feedback loops to control the dc level of the cathode voltage (cut-off), and gain of the signal at the cathode (white balance). There are three loops to control the dark currents dark loops and another three to control the gains bright loops. The system uses 3 lines at the end of the vertical suppression period and just before the beginning of the picture for sampling the cathode current (i.e., one line for red, one for green and one for blue). The first half of reach line is used for adjusting the gain of the channel and is usually called the "bright" adjustment period. The second half of the line is used for adjusting the dc level of the channel and is called the "dark" adjustment.

The theoretical circuit diagram for one channel is shown in Figure 13 along with the basic equations. The dc level (I<sub>DC</sub>) and gain (G) are both controlled by 7 bit DACs which receive data directly from latches in which the required values are stored between sampling periods.

Figure 13. Bright/Dark Current Control

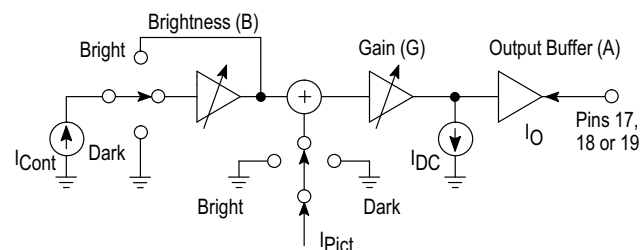

Picture Output Current:  $I_{O(Pict)} = A \times [I_{DC} = G \times ((B \times I_{Cont}) + I_{Pict})]$   
 Dark Sample Output Current:  $I_{O(dk)} = A \times I_{DC}$   
 Bright Sample Output Current:  $I_{O(br)} = I_{O(dk)} - A \times G \times I_{Cont}$   
 Black Level Output Current:  $I_{O(bk)} = I_{O(dk)} - B \times A \times G \times I_{Cont}$   
 $= I_{O(dk)} \times B \times I_{O(dk)} - I_{O(br)}$

A block diagram of the complete system is illustrated in Figure 16. Data words from the MCU which represent the RGB color temperatures selected at the factory, are stored in Latches 1,2,3 and D/A converted by DAC1,2,3 to reference currents. During the bright adjustment period, a reference current pulse, whose amplitude depends on the Contrast setting, is output to the cathode of the tube. The gain control is adjusted to bring the feedback current to the same value as the bright reference current, which is defined by the color intensity setting of the output considered. The currents must match each other. If not, a current will flow in resistor R producing an error voltage. This is then buffered into comparators Comp1, 2 and is compared with voltage references V<sub>ref1</sub> and V<sub>ref2</sub>. If the error voltage is greater than V<sub>ref1</sub>, Comp1 causes the counter to count up. If the error voltage is less than V<sub>ref2</sub>, Comp2 sends a count-down command. In this way, a "deadband" is set up to prevent the outputs from continuously changing. With the color intensity DAC set to about 32<sub>d</sub>, the bright cathode current is 100 μA (10 times the dark current).

During Load the contents of the counter are loaded into Latch 6 (for red dc) and then D/A converted. The resulting dc current is then applied as an offset to the red output amplifier, completing the loop. During the dark adjustment period, the same intensity data is used but divided by a common factor (typically 10). A black level reference pulse is applied and the feedback loop adjusts the dc levels of the cathode to obtain a set of cathode currents equal to the dark reference currents

(10  $\mu$ A). Therefore, the image color will always be adjusted to match the dark level color, i.e. grey scale tracking is ensured.

The Load/Backload sequencer is used to control which latch is being addressed at any given time by means of the timing signals input to it. The backload command sends the data from the appropriate latch to the Up/Down Counter, ready to be modified if necessary.

The Brightness control is affected by simply changing the dc pedestal of all three drives by the same amount, and does not form part of the feedback loop. The Contrast is adjusted to a set of values dependent on the level of the bright pulse applied during the set-up period. This level is set by a control word from the MCU. Once the loops have stabilized under normal working conditions, they may be deactivated by means of a control bit from the MCU. When, however, any change is made to either contrast or RGB intensity, the loops must be reactivated. For normal operation, it is not necessary to deactivate the bright loops.

Increasing the RGB intensity values will cause the Black-to-White cathode voltage amplitude to increase for a given Contrast setting. The White balance can therefore be set by adjusting the relative values of R, G and B intensity. An extra loop has been included via Latch 4 and DAC 4, which operates during the field flyback time to compensate for offsets within the loop. This has the effect of counteracting any input offset from the Buffer/Amp and will also compensate for cathode leakage should this be needed.

A second output of the reference currents from the RGB DACs are used to compare with preset limits, to ensure that the loops are working within their range of control. Should the limits be exceeded in either direction, flags are returned to the MCU to request that the G2 control be adjusted up or down as appropriate. Once set-up, the servo loops maintain the same conditions throughout the life of the TV.

### Horizontal Timebase

The horizontal timebase consists of a PLL which locks up to the incoming horizontal sync, and a phase detector and shifter whose purpose is to maintain the H-Drive in phase with the line flyback pulse.

Because of on-chip component tolerances, the free-running oscillator frequency cannot be set more accurately than  $\pm 40\%$ ; this range would be too much for the line output stage to cope with. For this reason the free-running frequency is calibrated periodically by other means. During startup and whenever there is a channel change, the phase detector is disconnected from the VCO for 2 lines during the blanking interval. A block diagram of the line timebase is given in Figure 14. The calibration loop consists of a frequency comparator driving an Up/Down Counter. The count is D/A converted to give a dc bias which is used to correct a 1.0 MHz VCO. The 1.0 MHz is divided by 64 to give line frequency and this is returned to the frequency comparator. This compares Fh from the VCO with a reference derived from dividing down the subcarrier frequency. Any difference in frequency will result in an output from the comparator, causing the counter to count up or down; and thus closing the loop. Since the horizontal oscillator is quite stable, this calibration does not need to be carried out very often. After switch-on, the calibration loop need only be enabled when the timebase goes out of lock.

A Coincidence Detector looks at the PLL Fh and compares it with the incoming H-sync. If they are not in lock, a flag is returned to the MCU. To allow for use with VCRs, the gain of

the phase detector may be switched by means of commands from the MCU (bits HGAIN1 and HGAIN2). The gain of the phase detector is switched to the maximum value at the end of the vertical sync pulse and then reduced to the selected value after about 11 lines. This allows the horizontal timebase to rapidly compensate any horizontal phase jump (e.g. with a VCR) during the vertical blanking period, thus avoiding bending at the top of the picture.

Twice line frequency is output from the PLL which may be divided by either 1 or 2 depending on the command of the MCU. The x2 Fh will be used with Feature Boxes. The phase of the Fh and flyback pulses are compared in a phase detector, whose output drives a phase shifter. A 6-bit control word and D/A converter are used to apply an offset to the phase detector giving a horizontal phase shift control.

The presence of the horizontal flyback pulse is detected; if it is missing a warning flag is sent back to the MCU which can take appropriate action.

### Vertical Timebase

The vertical timebase consists of two sections; a digital section which includes a vertical sync separator and standard recognition; and an analog section which generates a vertical ramp which may be modified under MCU control to allow for geometrical adjustments. A parabola is also generated and may be used for pin-cushion (E-W) correction and width control (see Figure 15).

In the digital section, the MC44002/7 uses a video sync separator which works using feedback, such that the threshold level of a comparator (slice level) is always maintained at the center of the sync pulse. Sync from any of the auxiliary inputs may also be used. The composite sync is fed to a vertical sync separator, where vertical sync is derived. This consists of a comparator, up/down counter and decoder. The counter counts up when sync is high, and down when sync is low. The output of the decoder is compared with a threshold level, the threshold only being reached with a high count during the broad pulses in the field interval.

When "Auto Countdown" is selected, the vertical timebase in fact starts off in the "Injection Lock" mode. This means that the timebase locks immediately to the first signal received, in exactly the same way as an old type injection locked timebase. A coincidence detector looks for counts of the right number (525 e.g.), and causes a 4 bit counter to count up. When there are 8 consecutive coincidences, the vertical countdown is engaged, and the MSB of the counter is brought out to set the flag. Similarly, non-coincidence, which will occur if synchronizing pulses are missing or in the wrong place, or if there is noise on the signals, causes the counter to count down. When the count goes back to zero, after 8 noncoincidences, the timebase automatically reverts to "Injection Lock" mode.

If it is known that lock will be lost (e.g., channel change), it is possible to jump straight into Injection Lock mode and not have to wait for the 8 consecutive non-coincidences. In this way the new channel will be captured rapidly. Once locked on to the new channel, "auto countdown" is then reselected by the MCU.

Under some conditions such as some VCRs in Search mode, it is possible to get signals having an incorrect number of lines, meaning that the countdown flag will go off because of successive non-coincidences. In these circumstances, if "auto countdown" is selected, the timebase will automatically lock to the signal in the Injection Lock mode. The fact that the

## MC44002 MC44007

flag is effectively saying that the vertical timebase is out of lock need not be a cause for major concern, since the horizontal timebase will still be locked to the signal, and has its own flag – “Horizontal out of lock”. The vertical countdown and horizontal lock flags both perform an independent test for the presence of a valid signal. A logical OR function can be performed on the two flags, such that if either are present then by definition a valid signal is present.

The vertical oscillator has end-stops set at two line-count decodes as given below:

$$50 \times 625 / 740 = 42.2 \text{ Hz (min)}$$

$$50 \times 625 / 448 = 69.8 \text{ Hz (max)}$$

These figures assume that the horizontal timebase is running at 15,625 Hz. When the vertical timebase is in Injection Lock mode, the line counter reset is inhibited so that it ignores any sync pulses before a count of 448 is reached. This prevents any possible attempted synchronization in the middle of the picture. If the count reaches 740 lines, then there is an automatic reset which effectively sets the lower frequency limit. The choice of these limits is a compromise between a wide window for rapid signal capture and a narrow window for good noise immunity.

It is also possible to run the timebase in 2.0 V mode as there are decodes for 100 Hz (2 x 50 Hz) operation with upper and lower limits in proportion. This is, of course, intended to be used in conjunction with field and frame memory stores. The similar decodes which would be necessary to allow 120 Hz (2 x 60 Hz) operation have not, for the present, been implemented. Finally, the timebase can be forced into a count of either 625 or 525 by commands from the MCU; in this mode the input signal, if present, is ignored completely. If there is no signal present save for noise, then this feature can be used to obtain a stable raster.

In the analog section, an adjustable current source is used to charge an external capacitor at Pin 6 to generate a vertical ramp. The amplitude of the ramp is varied according to the current source (Height), and is automatically adapted when the 525 standard is recognized by multiplying by 1.2. The Linearity control is achieved by squaring the ramp and either adding or subtracting a portion of it to the main linear current. In addition, a correction current, depending on the level of anode current, is applied in the sense of oppose a change of picture height with EHT (Breathing).

The final ramp with corrections added is then passed to a driver/amplifier and is output at Pin 7. The vertical ramp can be used to drive a separate vertical deflection power circuit with local feedback control. Vertical “S” Correction will then be made using fixed components within the feedback loop of the power op amp. The vertical position can be adjusted under MCU control – this is achieved by varying the dc output level at Pin 7. The vertical amplitude can be reduced to 75% of its original value (bit VDI) to make possible the display of a 16:9 picture on a 4:3 screen.

The reference ramp is squared to provide a pin-cushion correction parabola, developed across an external resistor at Pin 8. The parabola itself is squared, giving an independent fourth order term (Corner Correction) whose level can also be varied; this is then added as a further modifying term to the E-W output. This latter correction is used for obtaining good corner geometry with flat-square tubes. A variable dc current is added to the parabola to effect a width control. Using a suitable power amplifier and a diode-modulator in the line output stage, the parabola may be used for E-W correction and dynamic width control. A further control is provided to shift the center point of the parabola up and down the screen (Parabola Tilt).

All of the vertical and horizontal signals are adjustable via 6-bit words from the MCU, and stored in latches. The adjustment controls available are:

Vertical Amplitude/Linearity/Breathing Correction/Position  
Parabola (E-W) Amplitude/Horizontal Amplitude/  
Corner Correction, and Parabola Tilt

The Anode Current Sense at Pin 9 is also used as a beam current monitor. Two thresholds may be set, by the manufacturer, using external components. The first threshold sets a flag to the processor if beam current becomes excessive. The MCU could, e.g., reduce brightness and/or contrast to alleviate the condition. The second threshold sets a flag warning of an overload condition where the CRT phosphor could be damaged. If such a condition were to arise, the processor would be programmed to shut down the PSU.

The vertical blanking lines may be selected by means of a bit from the MCU for either the 525 or 625 standard. The interlace may also be suppressed again under the control of the processor (bits ICI, IFI).

# MC44002 MC44007

Figure 14. Horizontal Timebase

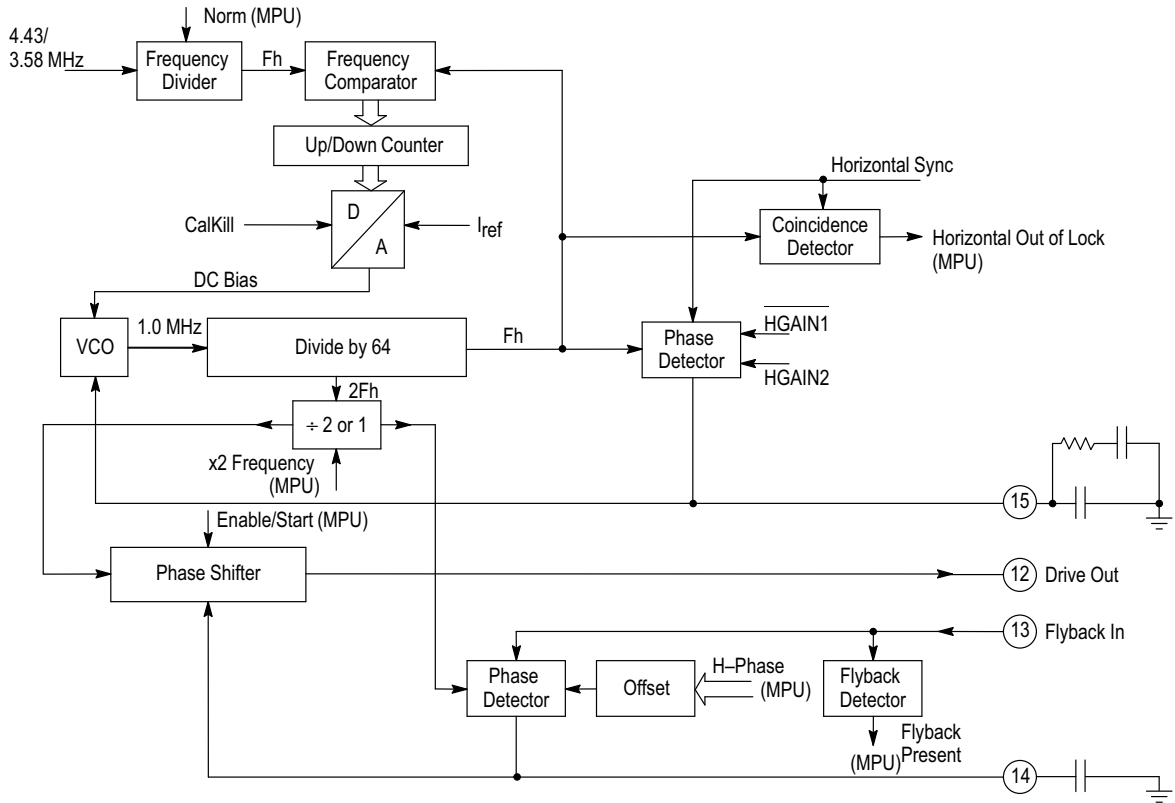

Figure 15. Vertical Timebase

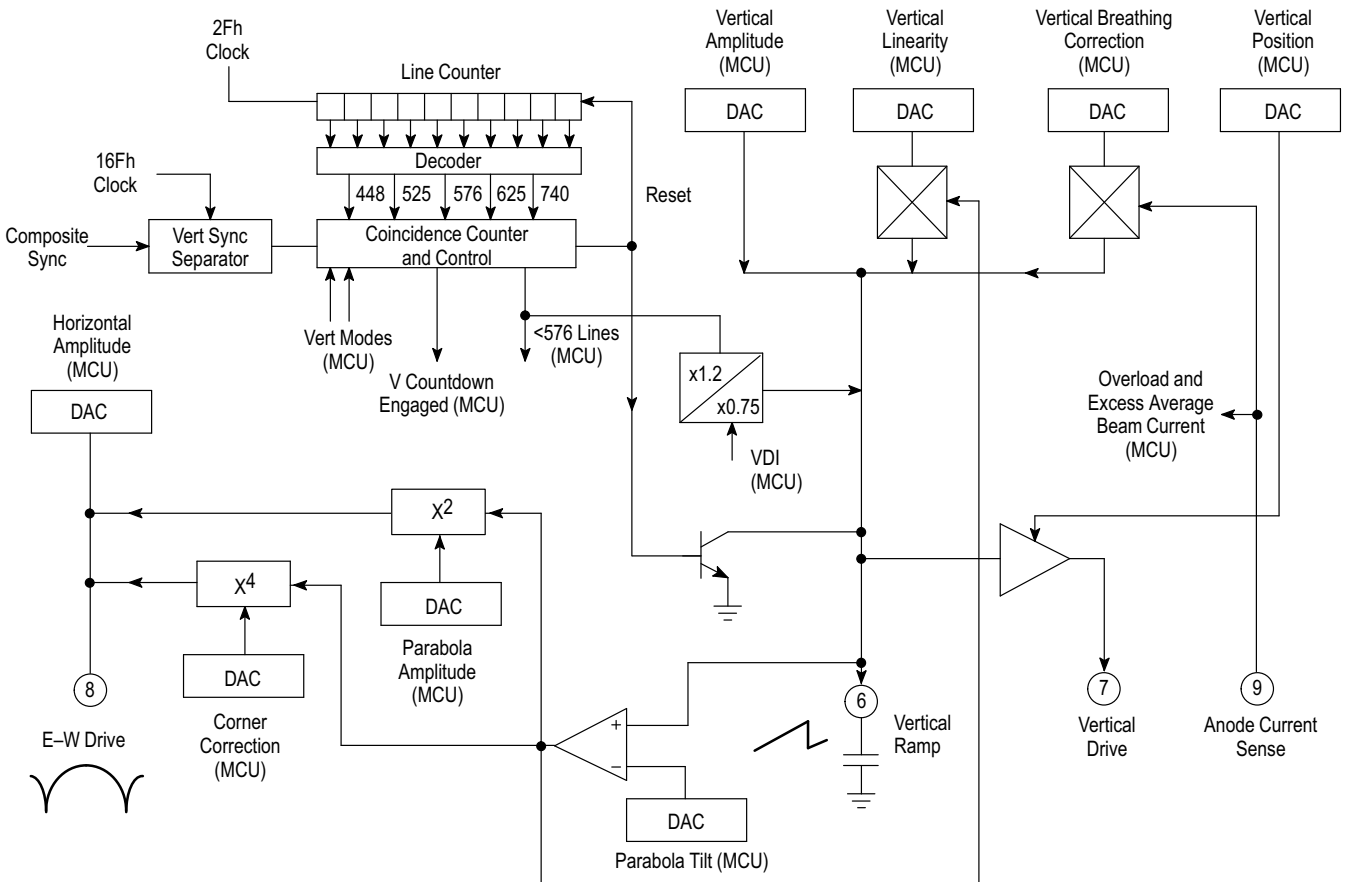
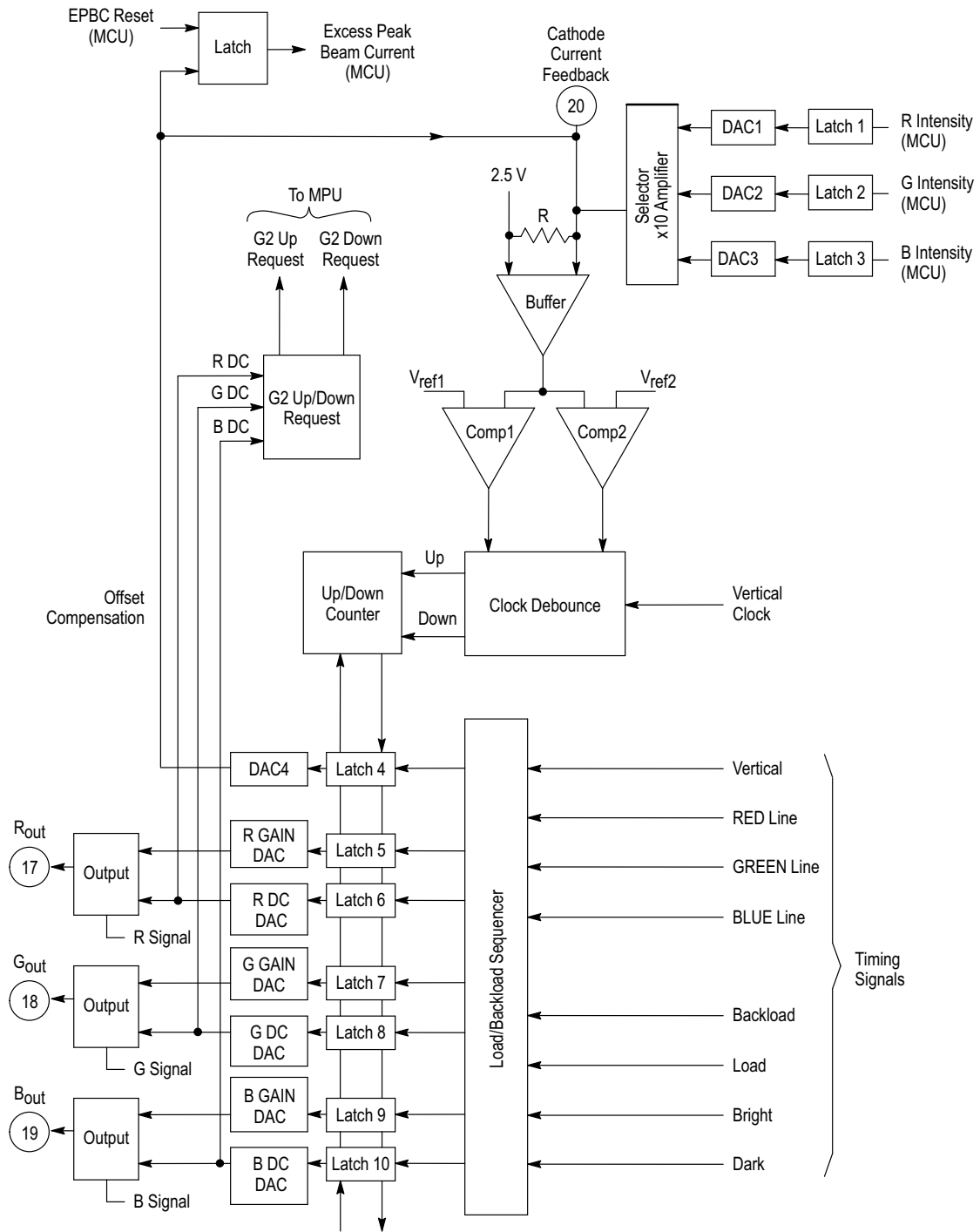

Figure 16. Auto Gray Scale Control Loops



**PIN FUNCTION AND EXTERNAL CIRCUIT REQUIREMENTS**

The following section describes the purpose and function of each of the 40 pins on the MC44002/7. There is also an explanation of the external circuit component requirements for a practical application; a diagram of the small signal circuit will be found in Figure 17. One of the primary design aims for the MC44002/7 was to use the minimum number of external components, and where these are necessary, to employ low

cost and easily obtainable standard types. Thus for example, as all the video signal filtering is carried out on the IC, there are no coils required whatsoever. The most common requirement is for ac coupling capacitors which are far too big to be integrated onto the chip. The time constants on certain pins are deliberately determined by external components to facilitate testing and for fine tuning the performance.

# MC44002 MC44007

## PIN FUNCTION DESCRIPTION

Pin	Equivalent Internal Circuit	Description
1		<p><b>ACC</b> External Filter used by ACC section. A single capacitor, that does not have a critical value, typically 0.01 μF, filters the feedback loop of the chroma automatic gain control amplifier.</p>
2 40		<p><b>Video Input 1 (Pin 40) and 2 (Pin 2)</b> Video inputs (Pin 2 = Video 2; Pin 40 = Video1); Intended for a nominal 1.0 Vpp input level of composite video. Separate luma and chroma components may also be used with these input pins for S-VHS. The external circuit requirement is for a coupling capacitor of 0.01 μF and a series resistance not exceeding 1.0 kΩ. The input selection and adaptation for Y and C is carried out in software.</p>
3		<p><b>Reference Current</b> Master reference current used throughout the IC. This is programmed by means of an external pull-up resistor, as on-board resistors are not sufficiently accurate. The designated current is 70 μA. This pin should be very well de-coupled to ground to avoid picking up interference from the nearby I<sup>2</sup>C bus inputs. Nominal voltage at the pin is 1.3 V.</p>
4		<p><b>I<sup>2</sup>C Clock</b> I<sup>2</sup>C bus clock input. This input can be taken straight into the IC, but in a real TV application it may be prudent to fit a series current limiting resistor near the pin in case of flash-over. A single pull-up resistor to 5.0 V is required. Although its value is associated with the μP, taking into account system capacitance at high data rates, a value of 4.7 kΩ, giving optimal performance, is recommended.</p>
5		<p><b>I<sup>2</sup>C Data</b> I<sup>2</sup>C data input. Comments above for Pin 4 also apply to this pin.</p>
6		<p><b>Vertical Ramp</b> A current is used to charge an external capacitor connected to this pin, developing a voltage sawtooth with a field period. The capacitor value determines the ramp amplitude. 82 nF is the more convenient value for symmetrical, linearity and parabola tilt adjustments.</p>

# MC44002 MC44007

## PIN FUNCTION DESCRIPTION (continued)

Pin	Equivalent Internal Circuit	Description
7		<p><b>Vertical Drive</b></p> <p>The sawtooth derived on Pin 6 is used to drive an external power amplifier vertical output stage. The amplitude, linearity and position of the output ramp are adjustable via the MCU.</p>
8		<p><b>Parabola (E-W) Drive</b></p> <p>An inverted parabolic waveform derived by squaring the vertical ramp is used to drive an external power amplifier. In sets fitted with a diode modulator type line output stage, this provides width control and pin-cushion correction. The parabola is squared again to give a fourth order correction term required for flat square tubes. The E-W amplitude, dc level, tilt and corner correction are all adjustable by means of the MCU. This is a current output and may be used, for example, to drive the virtual ground of an external power amplifier</p>
9		<p><b>Anode Current</b></p> <p>Used as an anode current monitor whose purpose is to: (1) Provide E.H.T. compensation (anti-breathing) for the vertical ramp; and (2) provide warning of excessive and overload beam current conditions.</p> <p>The pin is connected via about 560 kΩ series resistor to the bottom of the E.H.T. overwinding. Therefore, increasing beam current will pull the voltage on this pin more negative. This change is sensed within the chip and used to apply a correction to the ramp and parabola amplitudes. With large beam currents, thresholds at <math>+V_{be}</math> and <math>-2.0 V_{be}</math> set off warning flags to the MCU, which then has to take the appropriate action. The anode current levels at which these thresholds are reached are set up using fixed external resistors.</p>
10		<p><b>Anode Contrast</b></p> <p>This pin is used as an Analog Contrast monitor, allowing fast Beam Current Limiting (BCL). The fast BCL is controlled by Pin 10 voltage, which decreases with the contrast reduction (see typical curve).</p> <p>Above 2.5 V on the pin, the contrast remains maximum. Below 2.5, the contrast is reduced by about 12 dB, which is reached at about 1.0 V.</p>
11		<p><b>SECAM Calibration Loop</b></p> <p>This pin is used for the storage capacitor of the analog SECAM calibration loop (typically 100 nF). The capacitor is required regardless of whether or not SECAM will be decoded.</p>
12		<p><b>Horizontal Drive Output</b></p> <p>Horizontal drive pulses having an approximately even mark-to-space ratio emerge from this pin. This is an open-collector output which can sink up to 10 mA. However, taking this much current is not recommended since there is no separate ground pin available which may be connected near the line output stage; noise could be injected into the signal ground on the IC. Therefore, with a transformer driven line output stage, this output has been designed to be used with an extra external transistor inverter between the IC and the line driver. The transistor is open during the period when the line deflection transistor should be conducting.</p>

# MC44002 MC44007

## PIN FUNCTION DESCRIPTION (continued)

Pin	Equivalent Internal Circuit	Description
13		<p><b>Horizontal Flyback Input</b> Flyback sensing input taken from the line output transformer. These pulses are used by the 2nd horizontal loop for H-Phase control. A positive going pulse from 0 to 5.0 V amplitude is needed for correct operation. The internal impedance of the pin is about 50 k<math>\Omega</math> and an external attenuating series resistor of around 120 k<math>\Omega</math> will also be needed.</p>
14		<p><b>Horizontal Loop 2 Filter</b> Components at this pin filter the output of the phase detector in the 2nd horizontal loop. A simple external filter consisting of a 0.1 <math>\mu</math>F capacitor is required.</p>
15		<p><b>Horizontal Loop 1 Filter</b> Horizontal PLL loop time constant. Components at this pin filter the output of the phase detector in the 1st horizontal loop. The value of RC time constant is selected with external components to give a smooth recovery after the field interval disturbance and to ensure optimum performances in the presence of noise.</p>
17 18 19		<p><b>RGB Outputs</b> The R, G and B drives are current rather than voltage due to the limited headroom available with the 5.0 V supply line. The outputs themselves consist of open-collector transistors and these are used to drive the virtual ground point of the high voltage cathode amplifiers</p>
20		<p><b>Feedback</b> Current feedback sense derived from the video output amplifiers. The currents from all three guns are summed together as each is driven sequentially with known current pulses during the field interval. This feedback is then compared with internally set-up references. A low value ceramic capacitor to ground may be fitted close to this pin to help stabilize the control loops.</p> <p>A secondary function of this pin is for peak beam current limiting. When the feedback voltage during picture time becomes too great (i.e. too high beam current), a threshold at <math>V_{CC} + 3.0 V_{BE}</math> is exceeded at which time a flag is sent to the MCU. The MCU then has to carry out the function of peak beam limiter by e.g. reducing contrast until the flag goes off. The threshold current is set externally with a fixed resistor value.</p>
21		<p><b>Fast Commutate</b> A very fast active high switch (transition time 10 ns) used with text on the RGB inputs, for overlaying text on picture. This hardware switch may be enabled and disabled in software.</p>

# MC44002 MC44007

## PIN FUNCTION DESCRIPTION (continued)

Pin	Equivalent Internal Circuit	Description
22 23 24		<b>RGB Inputs</b> These external input signals to the color difference stages are ac coupled into the IC via 0.1 μF capacitors. They have a clamp and sync separator. The inputs should be driven from a source of less than 1.0 kΩ output impedance with 700 mVpp signal levels.
25		<b>Y2 Input</b> Auxiliary external input to MC44002/7 which can be used in conjunction with auxiliary color difference inputs and/or as a sync input. The pin should be driven from a source of less than 1.0 kΩ output impedance with 700 mVpp luminance signal. The signal must be ac coupled via an external 0.1 μF coupling capacitor. Internal clamp and sync separator are provided.
26 27		<b>B-Y and R-Y Inputs</b> Corrected color difference inputs from the MC44140. The signals are ac coupled via 0.1 μF capacitors and are clamped internally. The inputs should be driven from a source of less than 1.0 kΩ output impedance.
28		<b>Y1 Clamp</b> External capacitor used by the circuit which clamps the Y1 signal output on Pin 29. A typical value is 4.7 μF.
29		<b>Y1 Output</b> The luminance, after passing through the filter and delay line/peaking sections, is made available on this pin. It is also routed internally to the color difference stages.
30		<b>System Select</b> A multilevel dc output controlled in software, which is used by the MC44140 for system selection. Please refer to separate functional description of the MC44140 chroma delay line.
31		<b>Sandcastle</b> A special multilevel timing pulse derived in the MC44002/7 for use by the MC44140. Please refer to separate function description of the MC44140 chroma delay line.

# MC44002 MC44007

## PIN FUNCTION DESCRIPTION (continued)

Pin	Equivalent Internal Circuit	Description
32 33		<p><b>Crystals (Respectively 14.3 MHz and 17.7 MHz)</b>            Drive for externally fitted crystal clock reference for PAL, SECAM or NTSC. Four times <math>F_{SC}</math> is used. If the NTSC system is not going to be received, the 14.3 MHz crystal may be omitted. The crystal is parallel driven from a single pin and it requires a series load capacitance of appropriate value (usually 20 to 30 pF). Only crystals intended for VCO use should be fitted. The reference frequency is divided down in a capacitor chain to provide about 50 mV of clock reference for the MC44140.</p> <p>Positions for Pins 32 and 33 are selected by software.</p>
34 35		<p><b>5.0 V Supply (35) and Ground (34)</b>            Supply line, nominally 5.0 V, requiring about 120 mA. The actual voltage should be in the range of 4.75 to 5.25 V for usable results. It is recommended to decouple the supply line using a small ceramic capacitor mounted close to the supply and ground pins.</p>
36 37		<p><b>B-Y and R-Y Outputs</b>            Demodulated color difference outputs. These signals are ac coupled to the MC44140 for correction and delay with PAL and SECAM respectively. Signal level of about 1.4 V<sub>pp</sub> may be expected on B-Y output when using a standard 75% color bars input video signal.</p>
38		<p><b>Identification</b>            External filter used by R-Y identification circuit. The filter normally consists of a single capacitor whose value is a compromise between rapid identification and noise rejection. Experience has shown that 0.047 µF is a suitable value.</p>
39		<p><b>Oscillator Loop Filter</b>            External time constant for chroma PLL. The crystal reference oscillator is phase locked to the incoming burst in PAL and NTSC. A low value ceramic capacitor, for good noise immunity, is normally placed in parallel with a much longer RC time constant. The PLL pull-in range is reduced when the time constant on the pin is made bigger, allowing this function to be optimized by the user.</p>

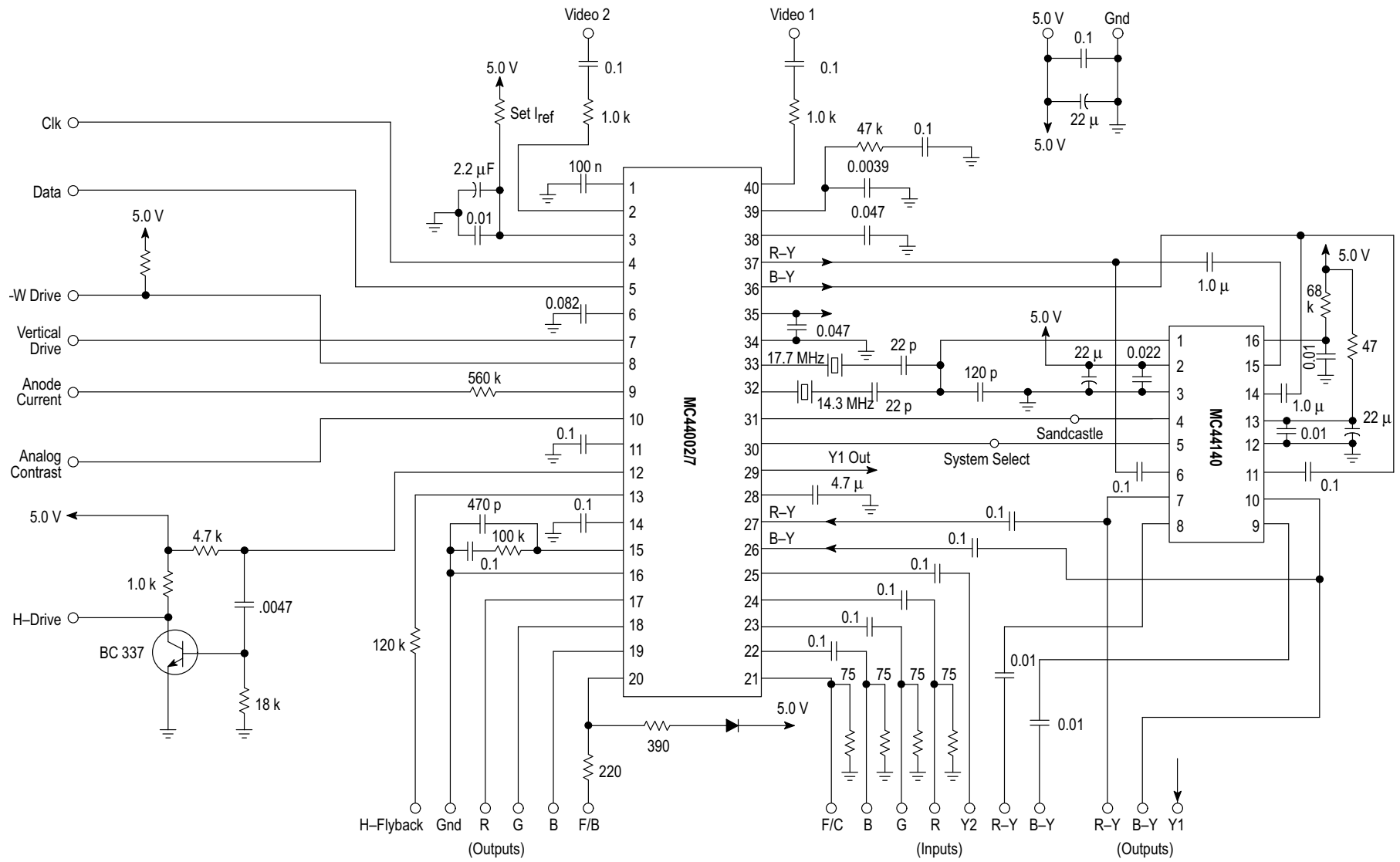

Figure 17. Typical Application Circuit

MC44002 MC44007

## MC44002 MC44007

### SOFTWARE CONTROL FUNCTIONS

#### General Description

As already related in the circuit description, the MC44002/7 has a memory of 18 bytes. All, except Sub-address 77 and 7F, use the 6 least significant bits as an analog control register with D/A converters (64 steps) within the memory section. The remaining bits are controlled individually for switching numerous functions. Table 2 gives a listing of all the memory registers and control bits. An explanation of the function of the 16 DACs is given below.

**Vertical Amplitude** – Changes the amplitude of the vertical ramp available on Pin 7.

**Vertical Breathing Correction** – A correction is applied to the vertical ramp amplitude in a sense opposite to the picture expansion and contraction produced by changes in beam current. This register alters the sensitivity of the beam current sensing and hence the size of correction applied for a given change in beam current.

**Parabola Amplitude** – Changes the amplitude of the E-W output parabola developed across an external pull-up resistor at Pin 8.

**Parabola Tilt** – Shifts the point of inflection of the E-W parabola from side to side along the time axis. Also known as *keystone correction*.

**Vertical Linearity** – The vertical ramp is multiplied by itself to give a squared term, a part of which is either added or subtracted to the linear ramp as determined by this register.

**Corner Correction** – An independent 4th order term which is subtracted from the E-W parabola to achieve correct geometry with flat square tubes.

**Horizontal Amplitude** – A variable dc offset applied to the E-W output parabola on Pin 8.

**Vertical Position** – Adjust the dc level of the vertical ramp on Pin 7, allowing vertical centering control.

**Horizontal Phase Control** – Applies a variable phase offset to the horizontal drive pulse at Pin 15 providing for a picture centering control.

**B, G, R Intensity** – These controls set up the current reference pulses used when sampling the beam current during field interval. The data is fixed by the TV manufacturer when setting up the White balance and the CRT for correct Gray Scale tracking.

(All the above registers are for use during the test and setting up procedures; the remaining 4 registers are also user controls.)

**Contrast** – During bright sample time during the field interval, this control varies the level of the current pulses injected into the R,G,B channels, so altering the picture contrast.

**Brightness** – A variable current pedestal which is added to the three drives during active picture time.

**Saturation** – A variable gain control for the two color difference signals.

**Hue** – Achieved by mixing a portion of one color difference signal into the other.

**Individually Adjustable Control Bits** – These consist of bits 7 and 6 of registers 77 through 88, as well as bits 0 to 5 of register 77 and bits 0 to 3 of register 7F. Some of these are used individually to control single functions requiring just on/off switching; and some are arranged into 2 or 3-bit words (e.g., luma peaking). A list of control words and truth tables for these may be found in Table 3.

**CA1, CB1** – Used to change the mode of operation of the vertical timebase to either injection lock or auto countdown, or to force it into 525 or 625 lines. Just prior to changing channel, the vertical timebase can be switched to injection lock mode and when a new channel is captured, the timebase is switched back to auto mode. In this way there is no delay in locking onto the new channel and hence no picture roll. If there is no valid signal being received, the display can be stabilized by forcing the timebase into 525 or 625 lines.

**IC1, IF1** – These bits are used to suppress the field interlace, which can be scanned in the nearest even or odd half line.

**HI, VI** – Selects the type of SECAM ident when operating in this mode. Either vertical ident bursts or horizontal ident can be selected individually, or ident can be taken from a combination of the two. In certain transmissions the vertical SECAM identification is not present (and sometimes replaced by other signals), so it is strongly recommended that only the horizontal identification be used. These bits must both be set to 1 when SECAM is not decoded (MC44002 and MC44007).

**SSA, SSB, SSC** – Used to set the color decoder and the dc level of the System Select output from the MC44002/7, Pin 30. This output is used by the MC44140 delay line in turn for changing between PAL, NTSC, SECAM and external modes of operation. In effect, the MC44140 is being controlled by the I<sup>2</sup>C bus via the MC44002/7.

## MC44002 MC44007

**Table 2a. Register Memory Map**

HEX Sub-address	MSB	Data Byte						LSB
77	T3	S-VHS	FSI	BAI	ICI	IFI	CBI	CAI
78	INTSEL	CALKILL	Vertical Amplitude					
79	HI	VI	Vertical Breathing Correction					
7A	XS	SSD	Parabola Amplitude					
7B	T1	T2	Parabola Tilt					
7C	SSC	SSA	Vertical Linearity					
7D	P1	SSB	Corner Correction					
7E	P3	P2	Horizontal Amplitude					
7F	D3	D1	Reserved	VDI	NT2	NT1	NT0	
80	D EN	D2	Vertical Position					
81	Y2 EN	Y1 EN	Horizontal Phase Control					
82	TEST	YX EN	Blue Intensity					
83	Not Used	HGAIN1	Green Intensity					
84	HGAIN2	NORM	Red Intensity					
85	BRI EN	2x Fh	Contrast					
86	SSE	H EN	Brightness					
87	SS1	Not Used	Saturation					
88	V1/V2	SS2	Hue					
00			Dummy – If H EN, then starts H timebase					
FF			Dummy – Resets peak beam limit flag					

# MC44002 MC44007

## Table 2b. Register Memory Map

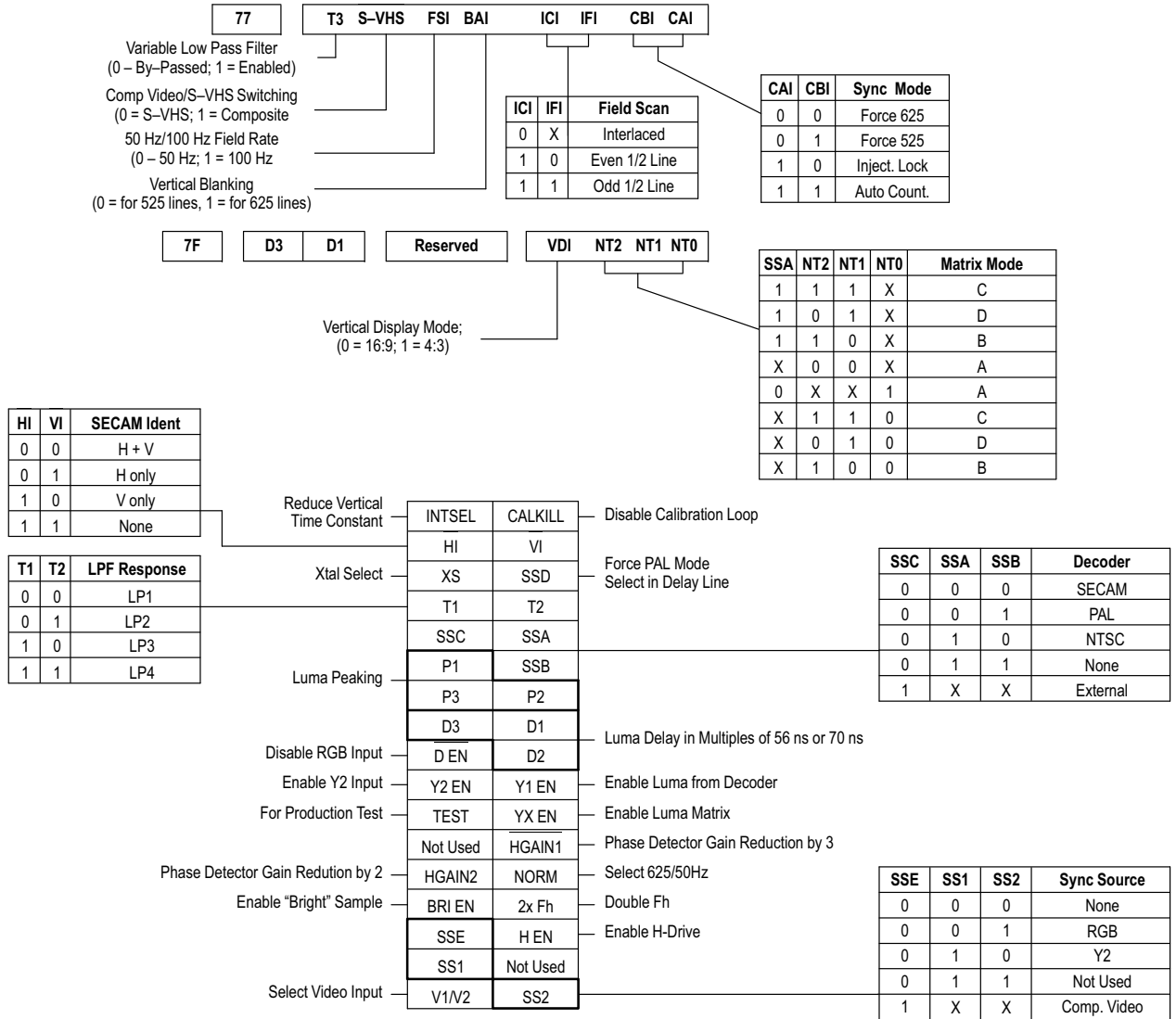

**NOTES:** SECAM decoding is selectable in the MC44002 only. HI and VI must be set to 1,1 in non-SECAM applications.

# MC44002 MC44007

Table 3. Control Bit Truth Tables

CAI	CBI	Sync Mode
0	0	Force 625
0	1	Force 525
1	0	Injection Lock
1	1	Auto Countdown

ICI	IFI	Field Scan
0	X	Interlaced
1	0	Even Up 1/2 Line
1	1	Odd Up 1/2 Line

HI	VI	SECAM Ident
0	0	H + V
0	1	H only
1	0	V only
1	1	None

T1	T2	LPF Response
0	0	LP1
0	1	LP2
1	0	LP3
1	1	LP4

SSC	SSA	SSB	Color Diff. Source
0	0	0	SECAM
0	0	1	PAL
0	1	0	NTSC
0	1	1	None
1	X	X	External

SSE	SS1	SS2	Sync Source
0	0	0	None
0	0	1	RGB
0	1	0	Y2
0	1	1	Not Used
1	X	X	Comp. Video

P2	P1	P3	Luma Peak (dB) @ 3.0 MHz *
0	0	0	8.5
0	0	1	8.0
0	1	0	7.2
0	1	1	6.3
1	0	0	5.4
1	0	1	3.8
1	1	0	2.3
1	1	1	0.0

\* Value shown for 17.7 MHz crystal.  
Peak Frequency is = 2.2 MHz when using 14.3 MHz crystal.

SSA	NT2	NT1	NT0	Matrix Mode
0	0	0	X	A
0	0	1	0	D
0	0	1	1	A
0	1	0	0	B
0	1	0	1	A
0	1	1	0	C
0	1	1	1	A
1	0	0	X	A
1	0	1	X	D
1	1	0	X	B
1	1	1	X	C

HGAIN1	HGAIN2	H-Phase Detector Gain
0	0	Divide by 3 (Sync Window Enabled)
0	1	Divide by 6 (Sync Window Enabled)
1	0	High (Sync Window Disabled)
1	1	Divide by 2 (Sync Window Disabled)

D1	D2	D3	PAL (T3 = 1)	NTSC (T3 = 1)	SECAM (T3 = 0)	S-VHS (T3 = 0)
0	0	0	780 ns	940 ns	1050 ns	N/A
0	0	1	836 ns	1010 ns	1106 ns	N/A
0	1	0	892 ns	1080 ns	1162 ns	N/A
0	1	1	948 ns	1150 ns	1218 ns	N/A
1	0	0	1004 ns	1220 ns	1274 ns	N/A
1	0	1	1060 ns	1290 ns	1330 ns	N/A
1	1	0	N/A	N/A	N/A	480 ns
1	1	1	N/A	N/A	N/A	480 ns

**SSE, SS1, SS2** – These 3 bits select the signal input from which the timebase synchronization is taken. The composite video input has a high quality sync separator which has been designed to cope with noise and interference on the video; the RGB and Y2 inputs have simple single sync separators which may also be used for synchronization.

**T1, T2** – The bits are used to modify the response of the variable Low Pass Filter placed at the composite video inputs (for PAL/NTSC signals) in order to compensate for IF filtering and the Q of external sound traps.

**P1, P2, P3** – These 3 bits are used to adjust the Luma peaking value. The amount of peaking indicated is with respect to the gain at the minimum peaking value (P1, P2, P3 = 111).

**D1, D2, D3** – These 3 bits are used to adjust the Luma delay. The indicated delay is that from the video inputs (Pins 2 and 40) to the Y1 output. The amount of delay depends on the composite video standard used if S-VHS is selected.

**NT0, NT1, NT2** – These 3 bits are used in conjunction with SSA for the selection of the matrix coefficients mode.

**HGAIN1, HGAIN2** – These 2 bits are used to set the gain of the horizontal phase detector. The high gain position is used to acquire lock and for operation with a VCR. Setting HGAIN1 to 0 also enables a horizontal sync window. The low gain position is used for off-the-air signals.

The remaining control bits are used singularly and are listed as follows:

**T3** – When high, this bit enables the variable Low Pass Filter at the video inputs. For optimum performance, T3 must be set to 0 in S-VHS and SECAM modes, and to 1 in PAL and NTSC. The filter response is set with bits T1, T2.

**S-VHS** – Set to 1 for normal composite video input to Pin 2 or 40. In this mode, the luma-chroma separator is active. Set to 0 for S-VHS (Y/C) operation at those pins. In this mode, luma is to be applied to the selected video input (with bit V1/V2), and chroma is to be applied to the other input. The luma-chroma separator is bypassed.

**FSI** – Selects either 50 Hz or 100 Hz field rate. When bit is low, 50 Hz operation is selected. No usable with NTSC.

**BAI** – This bit selects the number of blanked lines for either 525 or 625 line standards.

**INTSEL** – The vertical sync separator operates by starting a counter counting up at the beginning of each sync pulse, a field pulse being recognized only if the counter counts up to a sufficiently high value. The control bit INTSEL is used in taking the decision as to when a vertical sync pulse has been

detected. When low, the pulse is detected after 36  $\mu$ s; when high after 68  $\mu$ s. This may find application with anti-copy techniques used with some VCRs, which rely on a modified or corrupted field sync to allow a TV with a short time constant to display a stable picture. However, a VCR having a longer time constant will be unable to lock to the vertical.

**CALKILL** – Enables or disables the horizontal calibration loop. The loop is normally enabled only during startup for some seconds and when there is no signal present. The loop may be disabled so long as the horizontal timebase is locked to an incoming signal.

**XS** – Is used to change between the two external crystal positions (Pins 32 and 33).

**SSD** – Forces system select to PAL level. Can be used to override SECAM mode in the delay line. When low, SECAM mode is enabled (MC44002 only).

**VDI** – Either 4:3 or 16:9 display mode can be chosen using this bit. When low, the 16:9 mode is enabled.

**D EN** – Enables or disables the RGB Fast Commutation switch for the RGB inputs. When low, RGB inputs are enabled.

**Y1 EN** – Switches Y1 through to the color difference stage.

**Y2 EN** – Switches Y2 through to the color difference stage.

**Test** – When bit is low, enables continuous sampling by the RGB output control loops throughout the entire field period. Used only for testing the IC.

**YX EN** – Enables the luma matrix allowing saturation control in the color difference stage.

**Norm** – Alters the division ratio for the reference frequency used by the horizontal calibration loop. Always used when changing between 14.3 MHz and 17.7 MHz crystals.

**BRI EN** – Used to switch on or off the "bright" sampling pulses used by the RGB output loops. This feature was originally introduced to prevent any backscatter from these three bright lines in the field interval from getting into the picture. Must be enabled when adjusting intensity Contrast or Red, Green and Blue.

**2x Fh** – Line drive output is either standard 15.625 kHz (15.750 kHz) or at double this rate.

**H EN** – Control bit enables horizontal drive pulse. This is normally done automatically after the values stored in the MCU nonvolatile memory have been read into the MC44002/7 memory.

**V1/V2** – To select between Video Inputs 1 and 2.

## MC44002 MC44007

**Table 4. Control Bit Functions**

Bits	Bit Low	Bit High
T3	Variable Input LPF By-Passed	Variable Input LPF Enabled
S-VHS	S-VHS Mode Enabled	Composite Video Mode Enabled
FSI	50 Hz Field Rate Selected	100 Hz Field Rate Selected
BAI	Vertical Blanking for 525 Lines	Vertical Blanking for 625 Lines
INTSEL	Short Vertical Time-Constant	Long Vertical Time-Constant
CALKILL	H Calibration Loop Enabled	H Calibration Loop Disabled
XS	17.7 MHz Crystal (Pin 33) Selected	14.3 MHz Crystal (Pin 32) Selected
SSD	System Select Active	System Select Forced to PAL
D EN	RGB Inputs Enabled	RGB Inputs Disabled
Y2 EN	External Luma Input Switched "Off"	External Luma Input Switched "On"
Y1 EN	Luma from Filters Switched "Off"	Luma from Filters Switched "On"
TEST	Video Outputs Sampled Continuously	Video Outputs Sampled Once per Field
YX EN	Disable Luma Matrix (RGB Saturation Control)	Enable Luma Matrix (RGB Saturation Control)
HGAIN1	H-Phase Detector Gain Division by 3 Enabled	H-Phase Detector Gain Division by 3 Disabled
HGAIN2	H-Phase Detector Gain Division by 2 Disabled	H-Phase Detector Gain Division by 2 Enabled
NORM	H-Reference Divider Ratio for 17.7 MHz Crystal	H-Reference Divider Ratio for 14.3 MHz Crystal
BRI EN	"Bright" Sample Switched "Off"	"Bright" Sample Switched "On"
2 x fH	H-Drive : 1 x fH	H-Drive : 2 x fH
H EN	H-Drive Enabled	H-Drive Disabled
VDI	16:9 Display Mode Enabled	4:3 Display Mode Enabled
V1/V2	Video Input 2 (Pin 2) Selected	Video Input 1 (Pin 40) Selected

## MC44002 MC44007

### FLAGS RETURNED BY THE MC44002/7

When the Address Read/Write bit is high the last two bytes of I<sup>2</sup>C data are read by the MCU as status flags; a listing of these may be found in Table 5. The MC44002/7 is designed to be part of a closed-loop system with the MCU; these flags are the feedback mechanism which allow the MCU to interact with the MC44002/7.

A brief description of each of the flags, its significance and possible uses are given below.

**Table 5. Flags Returned**

Clock #	Flag (Bit High)
10	Horizontal Flyback Present
11	Horizontal Drive Enabled
12	Horizontal Out Of Lock
13	Excess Average Beam Current
14	Less Than 576 Lines
15	Vertical Countdown Engaged
16	Overload Average Beam Current
17	Reserved
18	(Acknowledge)
19	Grid 2 Voltage Up Request
20	Grid 2 Voltage Down Request
21	OK
22	Fault
23	ACC Active
24	PAL Identified
25	SECAM Identified (MC44002 only)
26	Excess Peak Beam Current
27	(Acknowledge)

**Horizontal Flyback Present** – A sense of the horizontal flyback is taken via a current limiting series resistor from one of the flyback transformer secondaries to Pin 13. This is used for the H-phase shift control, but the presence of the pulse is also flagged to the MCU. Should the flag be missing after the chassis has been started up, then the MCU would have to shut down the set immediately.

**Horizontal Drive Enabled** – Indicates that the horizontal drive pulse output at Pin 15 has been enabled. This occurs after the stored values in the nonvolatile memory have been transferred to the MC44002/7 memory.

**Horizontal Out of Lock** – This flag is high when no valid signal is being received by the MC44002/7. Possible action in this case would be to change the phase detector gain and time constant bits to ensure rapid capture and locking to a new signal.

**Excess Average Beam Current** – This is one of two threshold levels which are determined by an external component network connected to the beam current sensing at Pin 9. This flag indicates an excess of beam current. A typical application of this flag in conjunction with “Overload Average Beam Current” flag is for the software controlled

Automatic Beam Current Limiting. When this flag is “on”, it is recommended that the software prevent increases to the Contrast setting.

**Less Than 576 Lines** – Output from the line counter in the vertical timebase. If there is a count of less than 576 this is indicative of a 525 line system being received. If the flag is low then a 625 line system is being received. This information can be used as part of an automatic system selection software.

**Vertical Countdown Engaged** – The vertical timebase is based on a countdown system. The timebase starts in Injection Lock mode and when vertical retrace is initiated a 4-bit counter is set to zero. A coincidence detector looks for counts of 625 lines. In Auto mode each coincidence causes the counter to count up. When eight consecutive coincidences are detected, the countdown is engaged. The MSB of the counter is used to set this flag to the processor.

**Overload Average Beam Current** – This is the second threshold level which is set by the external component network on Pin 9. The flag warns of an overload in anode current which should be lowered by reducing the Contrast.

**Grid 2 Voltage Up/Down Requests** – These flags indicate when the RGB output loops are about to go out of the control range necessary for correct gray scale tracking. These 2 flags are used during factory adjustment.

**OK and Fault** – These two flags are included as a check on the communication line between the MCU and MC44002/7. The OK flag is permanently wired high and Fault is permanently wired low. The MCU can use these flags to verify that the data received is valid.

**ACC Active** – This flag is high when there is a sufficient level of burst present in PAL and NTSC modes during the video back porch period. The flag goes low when the level of burst falls below a set threshold or if the signal becomes too noisy. The flag is used to implement a software color killer in PAL and NTSC and is also available for system identification purposes. Since in SECAM there is line carrier present during the gating period, it is quite likely that the ACC will be on, or will flicker on and off in this mode.

\* **PAL Identified** – Recognizes the line-by-line swinging phase characteristic of the PAL burst. When this flag is on together with the ACC flag, this is positive identification for a PAL signal.

\* **SECAM Identified** – Senses the changing line-by-line reference frequencies (Fo1 and Fo2) present during the back porch period of the SECAM signal. This flag alone provides identification that SECAM is being received (MC44002 only).

**Excess Peak Beam Current** – A voltage threshold is set on the beam current feedback on Pin 20, which is also used for the RGB output loops for current sampling. When the threshold is reached, the flag is set, indicating too high a peak beam current which may be in only a part of the screen. The response of the MCU might be to reduce the contrast of the picture. This flag, together with the Excess Average Beam Current flag, performs the function of beam limiting. The exact way in which this is handled is left to the discretion of the user who will have their own requirements, which may be incorporated by the way in which the software is written.

\* These two flags are set in opposition to one another such that they can never both be on at the same time. This has been done to try to prevent misidentification from occurring. Often it is very difficult to distinguish between PAL and SECAM especially when broadcast material has been transcoded, sometimes badly, leaving e.g. large amounts of SECAM carrier in a transcoded PAL signal (also often with noise). With this method the strongest influence will win out making a misidentification much less likely.

## MC44002 MC44007

### APPENDIX A – SYSTEM IDENTIFICATION TABLE

The table below can be used for color standard selection between the normal PAL (I, BG), SECAM (L, BG) and NTSC (3.58 MHz – M) standards. Detecting the hybrid VCR standard (525 lines with 4.4 MHz chrominance) would entail switching back to the 17.7 MHz crystal in the event of there being no flag present with the 14.3 MHz crystal. The

MC44002/7 could also be used for the PAL M and N standards that are used in some parts of South America, but because the subcarrier frequencies differ by some kHz from the normal, crystals with a different center frequency would be required.

**Table 6. System Identification**

Flags from the MC44002/7				Crystal (MHz)	Standard Selected By MCU
<576 Lines	ACC On	PAL	SECAM		
0	0	0	0	17.7	Kill
0	0	0	1	17.7	SECAM
0	0	1	0	17.7	Kill
0	0	1	1	17.7	I <sup>2</sup> C Bus Error
0	1	0	0	17.7	Kill
0	1	0	1	17.7	SECAM
0	1	1	0	17.7	PAL
0	1	1	1	17.7	I <sup>2</sup> C Bus Error
1	0	0	0	14.3	NTSC Kill
1	0	0	1	14.3	NTSC Kill
1	0	1	0	14.3	NTSC Kill
1	0	1	1	14.3	I <sup>2</sup> C Bus Error
1	1	0	0	14.3	NTSC
1	1	0	1	14.3	NTSC
1	1	1	0	14.3	NTSC
1	1	1	1	14.3	I <sup>2</sup> C Bus Error

# MC44002 MC44007

## APPENDIX B – I<sup>2</sup>C BUS AND RGB CONTROL LOOPS WITH MC44002/7

The RGB drive DACs cannot be buffered on account of the chip area that this would take up. This factor has considerable implications on the way that the I<sup>2</sup>C data is written into the MC44002/7 memory. If the data for Brightness, Contrast, Saturation and Hue are transmitted at just any time, a disturbance will be visible on the screen.

To overcome this difficulty, a method synchronizing the MCU to write data only during the field interval has been developed. This represents something of a limitation, but has to be used only for the 4 user controls.

Another characteristic of the MC44002/7 is that the Contrast control function is carried out within the RGB sampling loops. If data is written into the registers during the time when the RGB loops are taking their samples, then the situation arises where data is being sampled and changed at

the same time. Hence, the loops will inevitably go unstable. When this happens, the brightness is seen to vary uncontrollably while the Contrast is changed. The effect has been described as “loop bounce”.

The timing diagram below show the exact situation.

From the start of the field flyback pulse to the beginning of the RGB sampling, approximately 1.2 ms is available to write the I<sup>2</sup>C data. Therefore, with a reasonable safety margin, the write time should be limited to only about 1.0 ms. This should not present any serious difficulty since only the data byte has to be transmitted during this time, and then only for the 4 user controls.

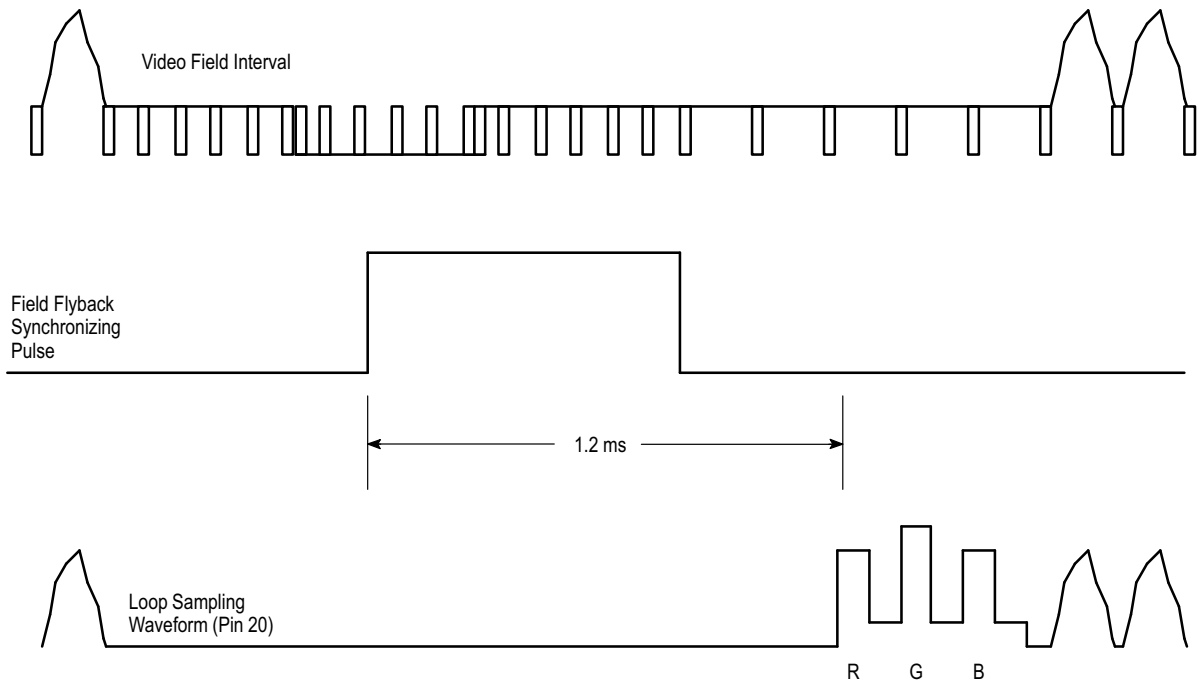

## APPENDIX C – A SUGGESTED METHOD FOR OUTPUT LOOPS ADJUSTMENT

As described in section 4, the MC44002/7 output loops stage automatically adjust the dc level of the cathode voltage (cut-off) and the gain of the signal at the cathode (white balance). These automatic adjustments replace the conventional manual adjustments. The only adjustment that must be carried out, either by hand or automatically using an "intelligent screwdriver", is for the G2 voltage.

As the G2 voltage is varied, the automatic output loops of the MC44002/7 will adjust the cathode voltage of the dark sample level to always obtain the correct dark cathode current. However, if the G2 voltage is adjusted too high or too low, one or more of the DAC's controlling the dc level will reach the end of their range and the cathode voltage on the channel will not be correctly adjusted. In order to inform the operator or machine adjusting the G2 voltage that the control range has been exceeded, the G2-Up Request or G2-Down Request flags will be set. These flags are set when any one of the dc-DAC's approaches the end of its range. The threshold for setting the flags lies typically between 15 and 20% of the range from the actual end. Therefore, when a flag is set, the output loops can still operate correctly. As the gain of the picture tube varies very little with the G2 voltage, flags are not provided for the gain-DAC's.

In order to fix a procedure for setting the G2 voltage it is necessary to consider several points:

- On a given sample, the output currents from the three channels corresponding to the dark level are all different. The range of each DAC is about 2.4 mA and varies little from one channel to another and from one device to another. For reasons of stability and control range we recommend that the feedback resistor of the high-voltage video amplifier be 39 k $\Omega$ . This means that the dark cathode voltage range of each channel is about 94 V (i.e. 39 k $\Omega$  x 2.4 mA), but the absolute value of the cathode voltage can vary.

- In a typical application the actual cut-off voltage (i.e. zero cathode current) lies about 10-15 V higher than the dark cathode current (10  $\mu$ A).

- When the beam-current in the picture tube increases, the G2 voltage tends to decrease. With the output loops of the MC44002/7, the cathode voltage is lowered automatically to compensate, but this effect would normally cause the values in the dc-DAC's to fall, using up their useful control range. As high beam current is associated to high contrast, in the MC44002/7 the dc output current (and therefore the cathode voltage) is reduced directly as the contrast setting is

increased. In this way as contrast is increased, leading to higher beam current and lower G2 voltage, the dc-DAC's do not move much, thus saving range.

- A picture tube can have a difference in cut-off voltage between guns of up to about 30 V and it is not generally possible to identify in a particular type and make of tube which gun has the lowest and which gun has the highest cut-off voltage. Also, it is generally recommended by the tube manufacturer to set the cut-off voltage of the highest gun to a certain value which gives optimum focus performance.

- As the picture tube ages, the cathode cut-off voltage falls. It is therefore best to set the G2 voltage when the tube is new to give the highest possible cathode cut-off voltage.

Taking into account the above points, it is recommended that the G2 voltage be set up in the following way:

- 1) Display a black picture with the brightness control to minimum. (This gives minimum beam current and no drop in G2 voltage.)

- 2) Set the contrast to maximum. (This causes the dc output current to be forced to a lower level and the output loops to compensate by moving towards the top of their range.)

- 3) Now adjust the G2 voltage so that the G2 Down Request flag is just turned off. (All the dc-DAC's are towards the top of their range and the highest one is just at the level to switch on the flag. Lowering the contrast setting, increasing the beam current or aging of the tube will cause the output loops to reduce the values in the dc-DAC's, but the available range will be a maximum.)

- 4) With a white picture and contrast set to give the maximum allowable beam current, check that the G2 Up Request flag is still off. (This is just to check that the G2 voltage is not falling too much at high beam current, but this step is not absolutely necessary.)

It is not recommended adjusting the G2 voltage to reach a specific value of cathode cut-off or dark voltage. The reason for this is that tolerances of the picture tube, high voltage video amplifier and the MC44002/7 itself will cause the dc-DACs to be set anywhere in their range and perhaps near the bottom end, leaving no margin for aging and G2 voltage drop.

# MC44002 MC44007

## OUTLINE DIMENSIONS

P SUFFIX  
PLASTIC PACKAGE  
CASE 711-03  
ISSUE C

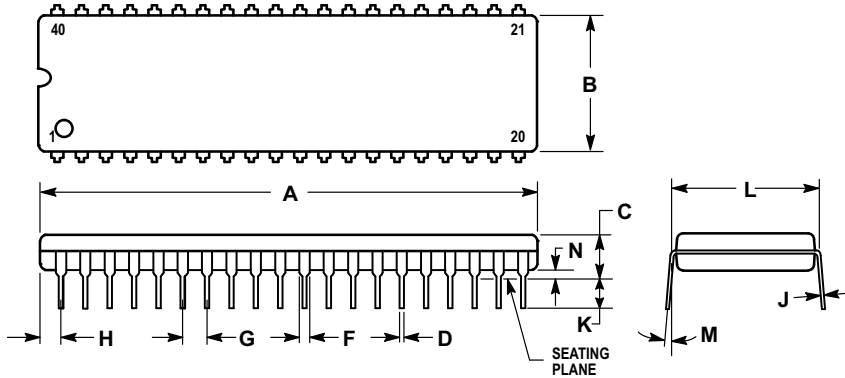

### NOTES:

1. POSITIONAL TOLERANCE OF LEADS (D), SHALL BE WITHIN 0.25 (0.010) AT MAXIMUM MATERIAL CONDITION, IN RELATION TO SEATING PLANE AND EACH OTHER.
2. DIMENSION L TO CENTER OF LEADS WHEN FORMED PARALLEL.
3. DIMENSION B DOES NOT INCLUDE MOLD FLASH.

DIM	MILLIMETERS		INCHES	
	MIN	MAX	MIN	MAX
A	51.69	52.45	2.035	2.065
B	13.72	14.22	0.540	0.560
C	3.94	5.08	0.155	0.200
D	0.36	0.56	0.014	0.022
F	1.02	1.52	0.040	0.060
G	2.54 BSC		0.100 BSC	
H	1.65	2.16	0.065	0.085
J	0.20	0.38	0.008	0.015
K	2.92	3.43	0.115	0.135
L	15.24 BSC		0.600 BSC	
M	0° 15°		0° 15°	
N	0.51	1.02	0.020	0.040

Motorola reserves the right to make changes without further notice to any products herein. Motorola makes no warranty, representation or guarantee regarding the suitability of its products for any particular purpose, nor does Motorola assume any liability arising out of the application or use of any product or circuit, and specifically disclaims any and all liability, including without limitation consequential or incidental damages. "Typical" parameters which may be provided in Motorola data sheets and/or specifications can and do vary in different applications and actual performance may vary over time. All operating parameters, including "Typicals" must be validated for each customer application by customer's technical experts. Motorola does not convey any license under its patent rights nor the rights of others. Motorola products are not designed, intended, or authorized for use as components in systems intended for surgical implant into the body, or other applications intended to support or sustain life, or for any other application in which the failure of the Motorola product could create a situation where personal injury or death may occur. Should Buyer purchase or use Motorola products for any such unintended or unauthorized application, Buyer shall indemnify and hold Motorola and its officers, employees, subsidiaries, affiliates, and distributors harmless against all claims, costs, damages, and expenses, and reasonable attorney fees arising out of, directly or indirectly, any claim of personal injury or death associated with such unintended or unauthorized use, even if such claim alleges that Motorola was negligent regarding the design or manufacture of the part. Motorola and  are registered trademarks of Motorola, Inc. Motorola, Inc. is an Equal Opportunity/Affirmative Action Employer.

### How to reach us:

**USA/EUROPE/Locations Not Listed:** Motorola Literature Distribution;  
P.O. Box 20912; Phoenix, Arizona 85036. 1-800-441-2447 or 602-303-5454

**MFAX:** RMFAX0@email.sps.mot.com - TOUCHTONE 602-244-6609  
**INTERNET:** <http://Design-NET.com>

**JAPAN:** Nippon Motorola Ltd.; Tatsumi-SPD-JLDC, 6F Seibu-Butsuryu-Center,  
3-14-2 Tatsumi Koto-Ku, Tokyo 135, Japan. 03-81-3521-8315

**ASIA/PACIFIC:** Motorola Semiconductors H.K. Ltd.; 8B Tai Ping Industrial Park,  
51 Ting Kok Road, Tai Po, N.T., Hong Kong. 852-26629298



MC44002/D

