

| | | |
|--------------|---------|---|
| SANYO | No.676D | 2SB808/2SD1012 |
| | | PNP/NPN Epitaxial Planar Silicon Transistors Low-Voltage Large-Current Amp Applications |

(): 2SB808

Absolute Maximum Ratings at $T_a=25^\circ\text{C}$

| | | | unit |
|------------------------------|-----------|-------------|------------------|
| Collector to Base Voltage | V_{CB0} | (-) 20 | V |
| Collector to Emitter Voltage | V_{CE0} | (-) 15 | V |
| Emitter to Base Voltage | V_{EB0} | (-) 5 | V |
| Collector Current | I_C | (-) 0.7 | A |
| Collector Current(Pulse) | I_{CP} | (-) 1.5 | A |
| Collector Dissipation | P_C | 250 | mW |
| Junction Temperature | T_j | 125 | $^\circ\text{C}$ |
| Storage Temperature | T_{stg} | -55 to +125 | $^\circ\text{C}$ |

Electrical Characteristics at $T_a=25^\circ\text{C}$

| | | | min | typ | max | unit |
|---|----------------|--|------|---------|---------|---------------|
| Collector Cutoff Current | I_{CB0} | $V_{CB}=(-)15\text{V}, I_E=0$ | | | (-) 1.0 | μA |
| Emitter Cutoff Current | I_{EB0} | $V_{EB}=(-)4\text{V}, I_C=0$ | | | (-) 1.0 | μA |
| DC Current Gain | $h_{FE(1)}$ | $V_{CE}=(-)2\text{V}, I_C=(-)50\text{mA}$ | 160* | | 960* | |
| | $h_{FE(2)}$ | $V_{CE}=(-)2\text{V}, I_C=(-)500\text{mA}$ | 80 | | | |
| Gain-Bandwidth Product | f_T | $V_{CE}=(-)10\text{V}, I_C=(-)50\text{mA}$ | | 250 | | MHz |
| Common Base Output Capacitance | c_{ob} | $V_{CB}=(-)10\text{V}, f=1\text{MHz}$ | | (13) | | pF |
| Collector to Emitter Saturation Voltage | $V_{CE(sat)1}$ | $I_C=(-)5\text{mA}, I_E=(-)0.5\text{mA}$ | | (-15) | (-35) | mV |
| | $V_{CE(sat)2}$ | $I_C=(-)100\text{mA}, I_E=(-)10\text{mA}$ | | (-60) | (-120) | mV |
| Base to Emitter Saturation Voltage | $V_{BE(sat)}$ | $I_C=(-)100\text{mA}, I_E=(-)10\text{mA}$ | | (-) 0.8 | (-) 1.2 | V |
| Collector to Base Breakdown Voltage | $V_{(BR)CBO}$ | $I_C=(-)10\mu\text{A}, I_E=0$ | | (-) 20 | | V |
| Collector to Emitter Breakdown Voltage | $V_{(BR)CEO}$ | $I_C=(-)1\text{mA}, R_{BE}=\infty$ | | (-) 15 | | V |
| Emitter to Base Breakdown Voltage | $V_{(BR)EBO}$ | $I_E=(-)10\mu\text{A}, I_C=0$ | | (-) 5 | | V |

* The 2SB808/2SD1012 are classified by 50mA h_{FE} as follows :

| | | | | | | | | |
|---------|-----|---|-----|-----|---|-----|-----|-------|
| 2SB808 | 160 | F | 320 | 280 | G | 560 | | |
| 2SD1012 | 160 | F | 320 | 280 | G | 560 | 480 | H 960 |

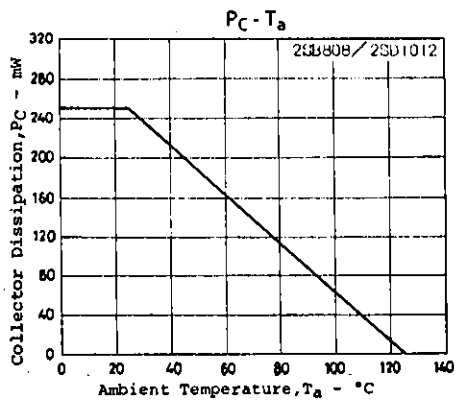

Package Dimensions 2033
(unit: mm)

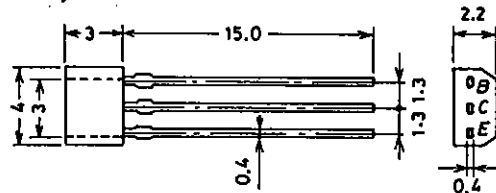

B: Base
C: Collector
E: Emitter

SANYO: SPA

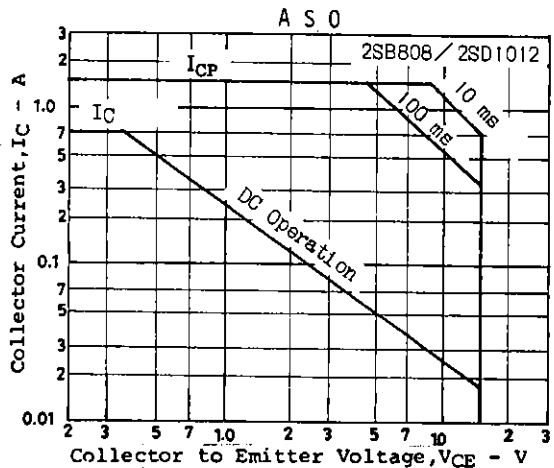
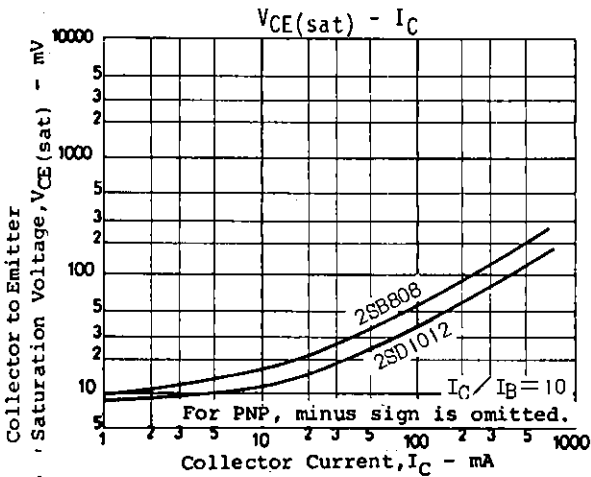
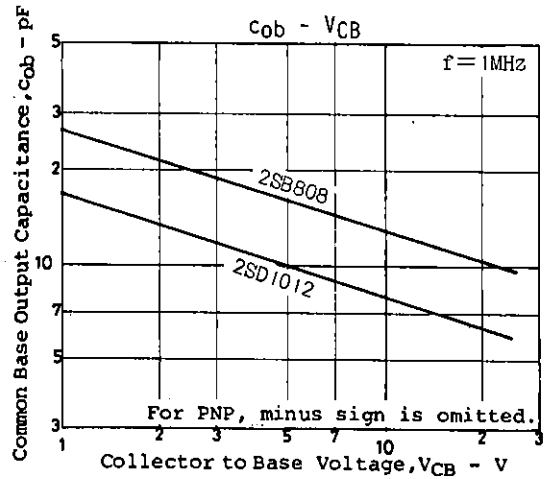
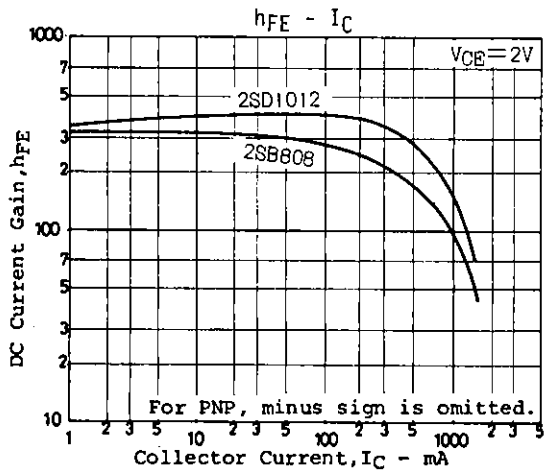
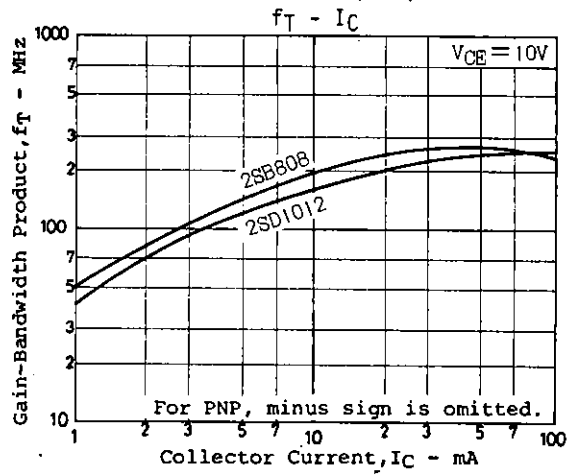
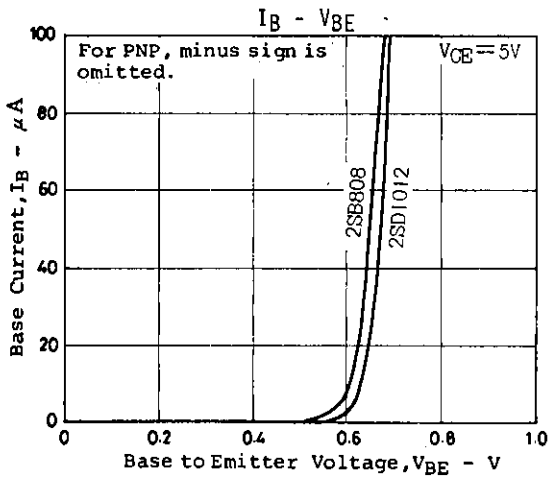
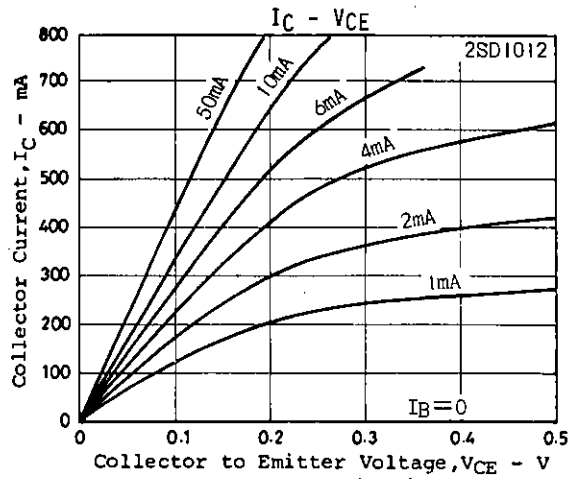
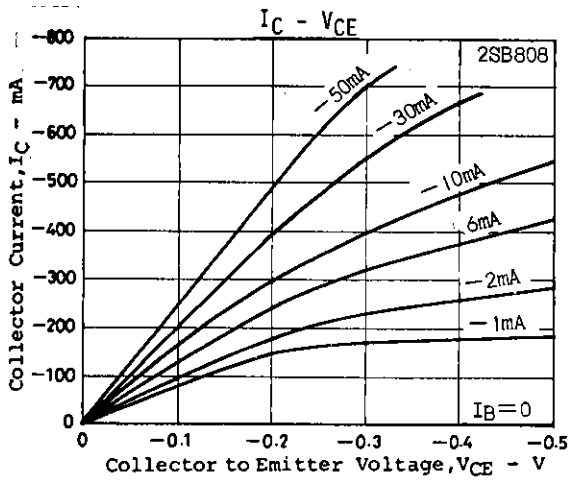

Sample Application Circuit : Low-voltage 3V(P_O 120mW) ITL-OTL power amp.

. Circuit configuration

For obtaining an output of more than 100mW, the middle-point voltage at the output stage and the collector voltage of the driver transistor must be $V_{CC}/2$. Therefore, the output stage is of quasi complementary configuration composed of npn/npn transistors. The phase is reversed by the 2SA608 and the middle-point voltage at the output stage and the collector voltage of the driver transistor are made to be $V_{CC}/2$ so that the output can be maximized.

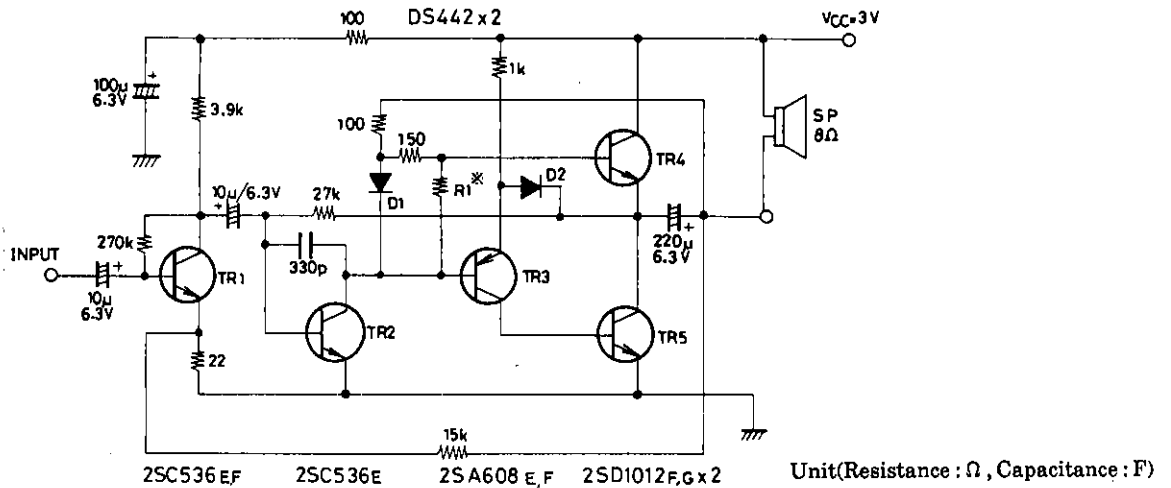

R_1 : Used control idle current
 For $R_1 = 820\Omega$, use rank F for [TR4,5(2SD1012)].
 For $R_1 = 680\Omega$, use rank G for [TR4,5(2SD1012)].

. Main Specifications

| Characteristic | Conditions | f=400Hz | f=1kHz | unit |
|---------------------------|--------------------------------------|--------------|--------------|------|
| Current dissipation | Quiescent, total current dissipation | 11.0 to 15.5 | 11.0 to 15.5 | mA |
| Output power | THD=10% | 120 to 125 | 127 to 130 | mW |
| Voltage gain | $P_O=10mW$ | 43.3 to 45.5 | 43.5 to 45.7 | dB |
| Total harmonic distortion | $P_O=50mW$ | 1.4 to 2.6 | 1.3 to 2.5 | % |
| Input resistance | $P_O=10mW$ | 10.4 to 20.5 | 11.0 to 21.0 | kΩ |

Note : For above-mentioned h_{FE} rank.

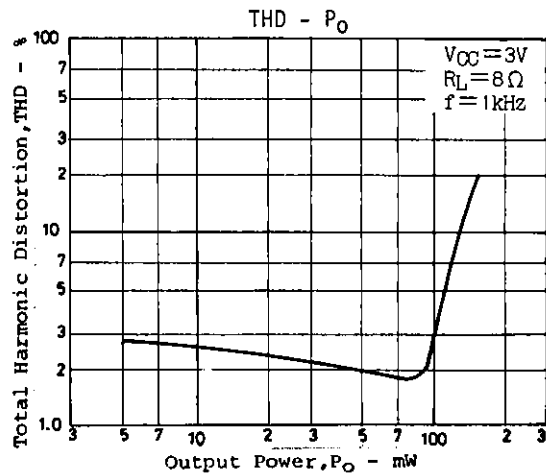
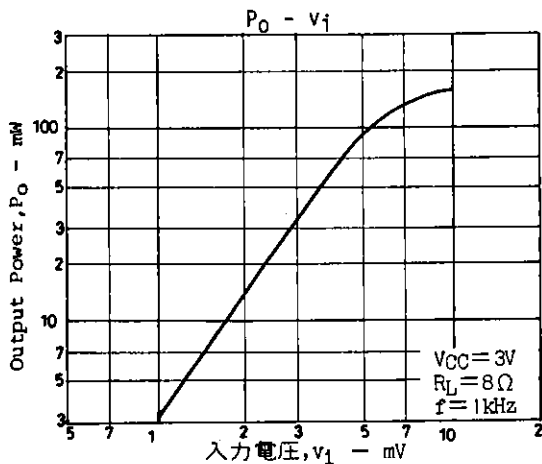

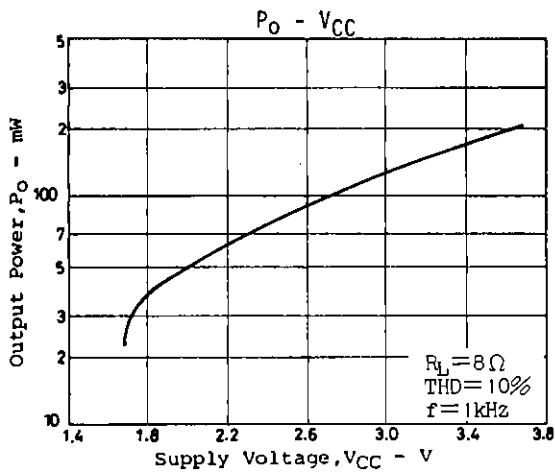
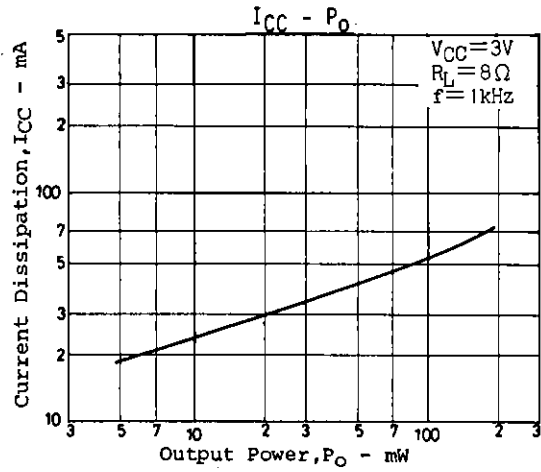
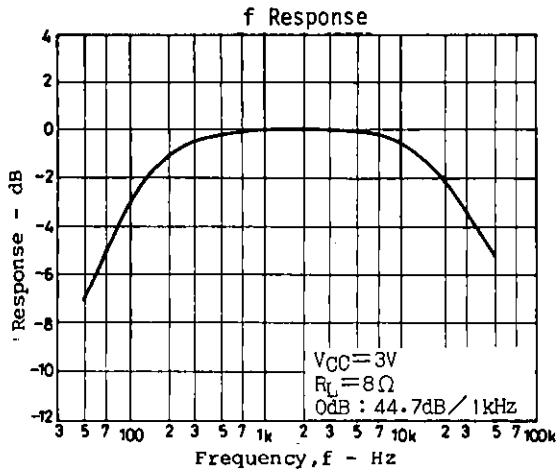

■ No products described or contained herein are intended for use in surgical implants, life-support systems, aerospace equipment, nuclear power control systems, vehicles, disaster/crime-prevention equipment and the like, the failure of which may directly or indirectly cause injury, death or property loss.

■ Anyone purchasing any products described or contained herein for an above-mentioned use shall:

- ① Accept full responsibility and indemnify and defend SANYO ELECTRIC CO., LTD., its affiliates, subsidiaries and distributors and all their officers and employees, jointly and severally, against any and all claims and litigation and all damages, cost and expenses associated with such use:
- ② Not impose any responsibility for any fault or negligence which may be cited in any such claim or litigation on SANYO ELECTRIC CO., LTD., its affiliates, subsidiaries and distributors or any of their officers and employees jointly or severally.

■ Information (including circuit diagrams and circuit parameters) herein is for example only; it is not guaranteed for volume production. SANYO believes information herein is accurate and reliable, but no guarantees are made or implied regarding its use or any infringements of intellectual property rights or other rights of third parties.