

**isc Silicon NPN Power Transistor**

**BU2727AW**

**DESCRIPTION**

- Collector-Emitter Sustaining Voltage-  
:  $V_{CEO(SUS)} = 825V$  (Min)
- High Switching Speed

**APPLICATIONS**

- Designed for use in horizontal deflection circuits of color TV receivers.

**ABSOLUTE MAXIMUM RATINGS( $T_a=25^{\circ}C$ )**

SYMBOL	PARAMETER	VALUE	UNIT
$V_{CES}$	Collector- Emitter Voltage( $V_{BE} = 0$ )	1700	V
$V_{CEO}$	Collector-Emitter Voltage	825	V
$V_{EBO}$	Emitter-Base Voltage	8	V
$I_C$	Collector Current- Continuous	12	A
$I_{CM}$	Collector Current-Peak	30	A
$I_B$	Base Current- Continuous	12	A
$I_{BM}$	Base Current-Peak	25	A
$P_C$	Collector Power Dissipation @ $T_C=25^{\circ}C$	125	W
$T_J$	Junction Temperature	150	$^{\circ}C$
$T_{stg}$	Storage Temperature Range	-65~150	$^{\circ}C$

**THERMAL CHARACTERISTICS**

SYMBOL	PARAMETER	MAX	UNIT
$R_{th\ j-c}$	Thermal Resistance, Junction to Case	1.0	$^{\circ}C/W$

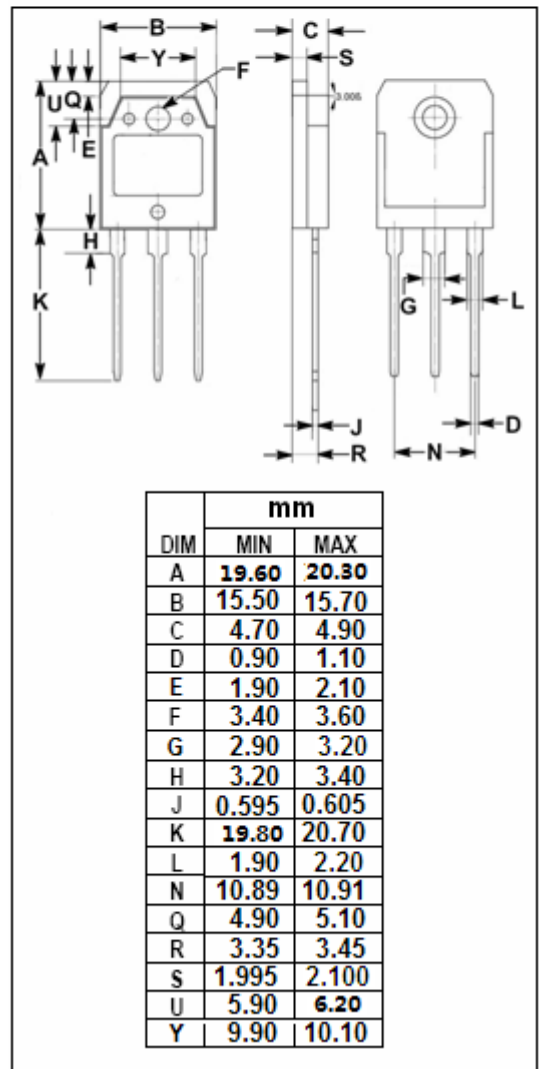
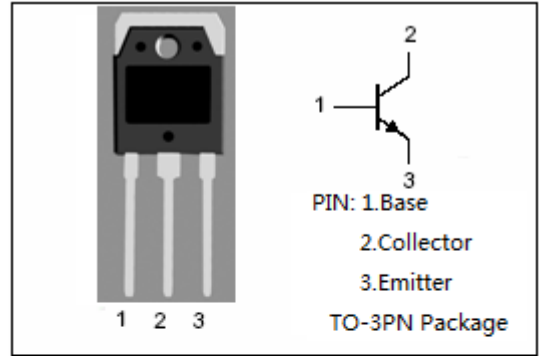

**isc Silicon NPN Power Transistor****BU2727AW****ELECTRICAL CHARACTERISTICS** $T_C=25^{\circ}\text{C}$  unless otherwise specified

SYMBOL	PARAMETER	CONDITIONS	MIN	TYP.	MAX	UNIT
$V_{CEO(SUS)}$	Collector-Emitter Sustaining Voltage	$I_C=30\text{mA}; I_B=0;$	825			V
$V_{(BR)EBO}$	Emitter-Base Breakdown Voltage	$I_E=1\text{mA}; I_C=0$	7.5			V
$V_{CE(sat)}$	Collector-Emitter Saturation Voltage	$I_C=5\text{A}; I_B=0.91\text{A}$			1.0	V
$V_{BE(sat)}$	Base-Emitter Saturation Voltage	$I_C=5\text{A}; I_B=0.91\text{A}$			0.95	V
$h_{FE-1}$	DC Current Gain	$I_C=0.1\text{A}; V_{CE}=5\text{V}$	12		35	
$h_{FE-2}$	DC Current Gain	$I_C=5\text{A}; V_{CE}=1\text{V}$	5.5		11	
$I_{CES}$	Collector Cutoff Current	$V_{CE}=1700\text{V}; V_{BE}=0$ $V_{CE}=1700\text{V}; V_{BE}=0; T_C=125^{\circ}\text{C}$			1.0 2.0	mA
$I_{EBO}$	Emitter Cutoff Current	$V_{EB}=7.5\text{V}; I_C=0$			1.0	mA