

TBA440C Monolithic Video IF Amplifier

General Description

The TBA440C is a monolithic video IF amplifier for color and monochrome television receivers.

The circuit includes three IF amplifier stages, a balanced video IF detector and a gated AGC section for the IF amplifier and PNP tuner.

Features

- High gain—high stability
- Minimal noise increase, incurred by use of AGC
- Minimum RF breakthrough to video outputs
- Fast AGC action—gating largely independent of pulse shape and amplitude
- Very low intermodulation products
- Positive and negative video signals are available from low impedance outputs
- Integrated temperature compensating circuit

Connection Diagram

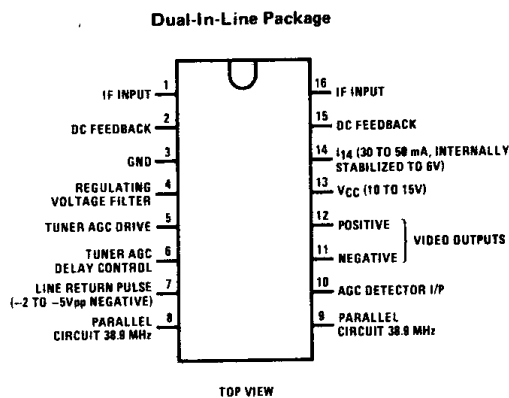

Order Number TBA440C
See NS Package N16A

Order Number TBA440CQ
See NS Package N16C

Test Circuit

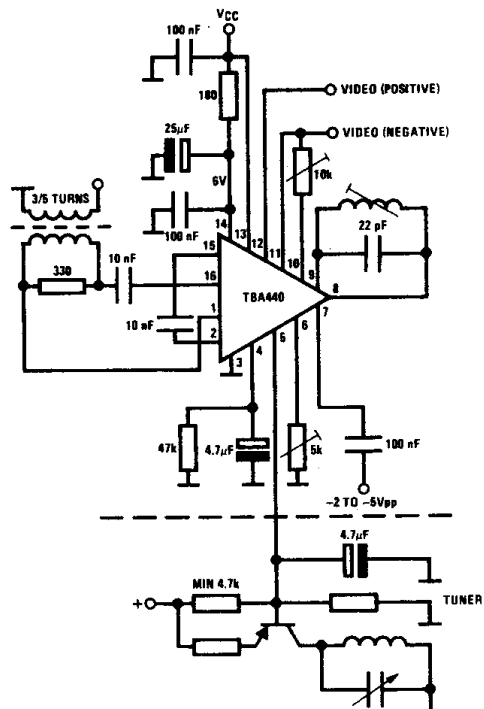

Absolute Maximum Ratings

Supply Voltage	15V
Current Into Pin 14	50 mA
Power Dissipation	700 mW
Maximum Resistance Between Pins 8 and 9	20 Ω
Operating Temperature Range	-25°C to +70°C
Storage Temperature Range	-65°C to +150°C
Lead Temperature (Soldering, 10 seconds)	300°C

Electrical Characteristics (T_A = 25°C, V_{CC} = 13V, I₁₄ = 40 mA, unless otherwise specified)

PARAMETER	CONDITIONS	MIN	TYP	MAX	UNITS	
I ₁₃	Current Consumption	V ₁₃ = 15V	14.5	17.5	20.5	mA
V ₁₄	Internal Supply Voltage	I ₁₄ = 40 mA, V _{IN} = 0	5.5	6.0	6.8	V
V ₁₁	DC Voltage at Output	V _{IN} = 0	5.5	7	8.5	V
V ₁₂	DC Voltage at Output		1.7	3	4.3	V
I ₅	Control Current for Tuner AGC	(10 dB After Beginning of the Tuner AGC, V ₅ \geq 2V)	3			mA
V ₄	IF Control Voltage for G _{MAX}		0		0.5	V
V ₄	IF Control Voltage for G _{MIN}		2.5			V
V ₇	Voltage for AGC Gating Input		-5		-2	V
R ₁₀₋₁₁	Resistance for Output Voltage	V ₁₁ = 3 V _{p-p}	3	4	10	k Ω
I ₁₁ , I ₁₂	Available Output Current to Ground				5	mA
I ₁₁ , I ₁₂	Available Output Current to V _{CC} +		-1			mA
Z ₁₋₁₆	Input Impedance at G _{MAX}			1.8/2		k Ω /pF
Z ₁₋₁₆	Input Impedance at G _{MIN}			1.9/0		k Ω /pF
V _{IN}	Input Voltage	V ₁₁ = 2 V _{p-p} , (Note 1)		100		μ V
V _{IN}	Input Voltage	V ₁₁ = 3 V _{p-p} , (Note 1)		150		μ V
B _{VIDEO}	Video Bandwidth			9		MHz
G _V	AGC Range		50	55		dB
	Sound/Chroma Intermodulation Products	(Note 2)	-40			dB

Note 1: RMS of sync tip voltage, see test circuit.

Note 2: Sound subcarrier -24 dB
Color subcarrier -2 dB