

Silicon NPN Power Transistor

BUH313D

DESCRIPTION

- High Switching Speed
- High Voltage
- Built-in Integrated Diode

APPLICATIONS

- Horizontal deflection stage in standard and high resolution Displays for TV's and monitors.

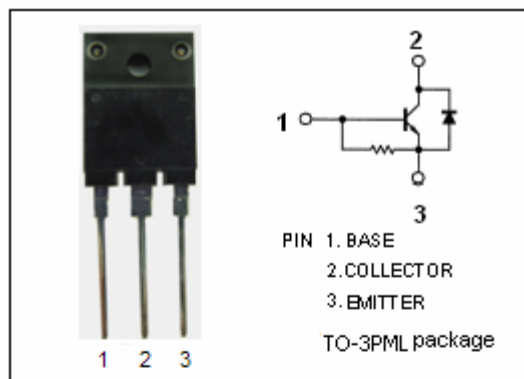

ABSOLUTE MAXIMUM RATINGS(T_a=25)

SYMBOL	PARAMETER	VALUE	UNIT
V _{CBO}	Collector-Base Voltage	1200	V
V _{CEO}	Collector-Emitter Voltage	600	V
V _{EBO}	Emitter-Base Voltage	10	V
I _C	Collector Current-Continuous	5	A
I _{CM}	Collector Current-Peak	8	A
I _B	Base Current	3	A
I _{BM}	Base Current-Peak	5	A
P _C	Collector Power Dissipation @T _C =25	50	W
T _J	Junction Temperature	150	
T _{stg}	Storage Temperature	-65~150	

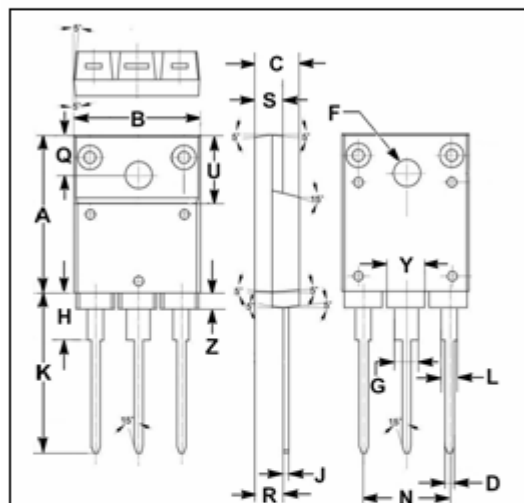

DIM	mm	
	MIN	MAX
A	19.90	20.10
B	15.90	16.10
C	5.50	5.70
D	0.90	1.10
F	3.30	3.50
G	2.90	3.10
H	5.90	6.10
J	0.595	0.605
K	22.30	22.50
L	1.90	2.10
N	10.80	11.00
Q	4.90	5.10
R	3.75	3.95
S	3.20	3.40
U	9.90	10.10
Y	4.70	4.90
Z	1.90	2.10

THERMAL CHARACTERISTICS

SYMBOL	PARAMETER	MAX	UNIT
R _{th j-c}	Thermal Resistance, Junction to Case	2.5	/W

Silicon NPN Power Transistor

BUH313D

ELECTRICAL CHARACTERISTICS

 $T_C=25$ unless otherwise specified

SYMBOL	PARAMETER	CONDITIONS	MIN	TYP	MAX	UNIT
$V_{CEO(SUS)}$	Collector-Emitter Sustaining Voltage	$I_C=100mA; I_B=0, L=25mH$	600			V
$V_{CE(sat)}$	Collector-Emitter Saturation Voltage	$I_C=3A; I_B=0.75A$			1.5	V
$V_{BE(sat)}$	Base-Emitter Saturation Voltage	$I_C=3A; I_B=0.75A$			1.3	V
I_{EBO}	Emitter Cutoff Current	$V_{EB}=5V; I_C=0$			300	mA
I_{CES}	Collector Cutoff Current	$V_{CE}=1200V; V_{BE}=0$ $V_{CE}=1200V; V_{BE}=0; T_C=125$			1.0 2.0	mA
h_{FE}	DC Current Gain	$I_C=3A; V_{CE}=5V$ $I_C=3A; V_{CE}=5V; T_C=100$	5 3			
V_{ECF}	C-E Diode Forward Voltage	$I_F=3A$			2.5	V

Switching Times; Resistive Load

t_s	Storage Time	$I_C=3A; I_{B1}=1A; I_{B2}=1.5A$ $V_{CC}=400V$		1.8	2.7	μs
t_f	Fall Time			0.2	0.3	μs