

SOT-23 Formed SMD Package

**BCV71
BCV72**

SILICON PLANAR EPITAXIAL TRANSISTORS

N-P-N transistors

Marking

BCV71 = K7
BCV72 = K8

PACKAGE OUTLINE DETAILS
ALL DIMENSIONS IN mm

Pin configuration
1 = BASE
2 = EMITTER
3 = COLLECTOR

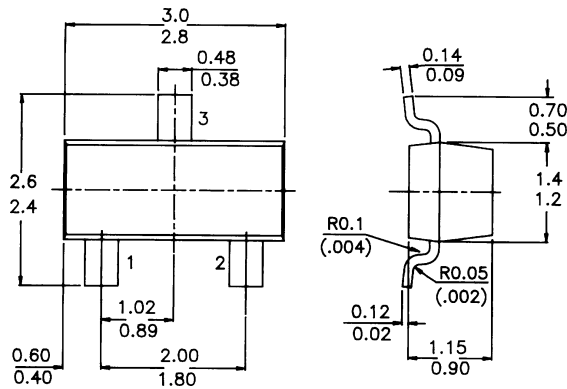
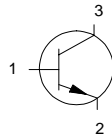

ABSOLUTE MAXIMUM RATINGS

		BCV71	BCV72
D.C. current gain at $T_j = 25\text{ }^\circ\text{C}$	$>$	110	200
$I_C = 2\text{ mA}; V_{CE} = 5\text{ V}$	h_{FE}	$<$ 220	450
Collector-base voltage (open emitter)	V_{CB0} max.	80	V
Collector-emitter voltage (open base)	V_{CE0} max.	60	V
Collector current (peak value)	I_{CM} max.	200	mA
Total power dissipation up to $T_{amb} = 25\text{ }^\circ\text{C}$	P_{tot} max.	250	mW
Junction temperature	T_j max.	150	$^\circ\text{C}$
Transition frequency at $f = 35\text{ MHz}$	f_T typ.	300	MHz
Noise figure at $R_S = 2\text{ kW}$	F	$<$ 10	dB
$I_C = 200\text{ mA}; V_{CE} = 5\text{ V};$			
$f = 1\text{ kHz}; B = 200\text{ Hz}$			

BCV71
BCV72

RATINGS (at $T_A = 25^\circ\text{C}$ unless otherwise specified)

Limiting values

Collector-base voltage (open emitter)	V_{CB0}	max.	80 V
Collector-emitter voltage (open base)	V_{CE0}	max.	60 V
$I_C = 2 \text{ mA}$	V_{EB0}	max.	5 V
Emitter-base voltage (open collector)	I_C	max.	100 mA
Collector current (d.c.)	I_{CM}	max.	200 mA
Collector current (peak value)	P_{tot}	max.	250 mW
Total power dissipation up to $T_{amb} = 25^\circ\text{C}$	T_{stg}	-55 to +150	$^\circ\text{C}$
Storage temperature	T_j	max.	150 $^\circ\text{C}$
Junction temperature			

THERMAL RESISTANCE

From junction to ambient	$R_{th\ j-a}$	=	500 K/W
--------------------------	---------------	---	---------

CHARACTERISTICS

$T_j = 25^\circ\text{C}$ unless otherwise specified

Collector cut-off current

$I_E = 0; V_{CB} = 20 \text{ V}$	I_{CB0}	<	100 nA
$I_E = 0; V_{CB} = 20\text{V}; T_j = 100^\circ\text{C}$	I_{CB0}	<	10 mA

Base emitter voltage

$I_C = 2 \text{ mA}; V_{CE} = 5 \text{ V}$	V_{BE}	550 to 700 mV
--	----------	---------------

Saturation voltages

$I_C = 10 \text{ mA}; I_B = 0,5 \text{ mA}$		typ.	120 mV
	V_{CEsat}	<	250 mV
	V_{BEsat}	typ.	750 mV

$I_C = 50 \text{ mA}; I_B = 2,5 \text{ mA}$	V_{CEsat}	typ.	210 mV
	V_{BEsat}	typ.	850 mV

D.C. current gain

		BCV71	BCV72
$I_C = 10 \text{ mA}; V_{CE} = 5 \text{ V}$	h_{FE}	typ. 90	150
$I_C = 2 \text{ mA}; V_{CE} = 5 \text{ V}$	h_{FE}	> 110	200
		< 220	450

Collector capacitance at $f = 1 \text{ MHz}$

$I_E = I_c = 0; V_{CB} = 10\text{V}$	C_c	typ.	2,5 pF
--------------------------------------	-------	------	--------

Transition frequency at $f = 35 \text{ MHz}$

$I_C = 10 \text{ mA}; V_{CE} = 5 \text{ V}$	f_T	typ.	300 MHz
---	-------	------	---------

Noise figure at $R_S = 2 \text{ kW}$

$I_C = 200 \text{ mA}; V_{CE} = 5 \text{ V}$	F	<	10 dB
$f = 1 \text{ kHz}; B = 200 \text{ Hz}$			

Disclaimer

The product information and the selection guides facilitate selection of the CDIL's Discrete Semiconductor Device(s) best suited for application in your product(s) as per your requirement. It is recommended that you completely review our Data Sheet(s) so as to confirm that the Device(s) meet functionality parameters for your application. The information furnished on the CDIL Web Site/ CD is believed to be accurate and reliable. CDIL however, does not assume responsibility for inaccuracies or incomplete information. Furthermore, CDIL does not assume liability whatsoever, arising out of the application or use of any CDIL product; neither does it convey any license under its patent rights nor rights of others. These products are not designed for use in life saving/support appliances or systems. CDIL customers selling these products (either as individual Discrete Semiconductor Devices or incorporated in their end products), in any life saving/support appliances or systems or applications do so at their own risk and CDIL will not be responsible for any damages resulting from such sale(s).

CDIL strives for continuous improvement and reserves the right to change the specifications of its products without prior notice.



CDIL is a registered Trademark of
Continental Device India Limited

C-120 Naraina Industrial Area, New Delhi 110 028, India.
Telephone + 91-11-579 6150 Fax + 91-11-579 9569, 579 5290
e-mail sales@cdil.com www.cdil.com