

SANYO

No. 2783

LC7020AK, 7020BK

Controller for PLL Frequency Synthesizer

The LC7020AK, BK are controllers for direct PLL ICs LM7000, LM7001. They can be used to form a PLL frequency synthesizer (without clock, 4 bands) for car use.

1. Functions and Features

(1) Receiving frequency

Area	Band	Receiving Frequency Range	Step	Reference Frequency	Intermediate Frequency
Japan	FM	76.0 to 90.0 MHz	100 kHz	100 kHz	-10.7 MHz
	MW	522 to 1629 kHz	9 kHz	9 kHz	450 kHz
U.S.A.	FM	87.5 to 108.0 MHz	100 kHz	100 kHz	+10.7 MHz
		87.5 to 108.1 MHz	200 kHz	100 kHz	+10.7 MHz
	MW1	530 to 1620 kHz	10 kHz	10 kHz	450 kHz
	MW2	531 to 1620 kHz	9 kHz	9 kHz	450 kHz
Europe	FM	87.5 to 108.0 MHz	25 kHz	25 kHz	+10.7 MHz
			50 kHz	50 kHz	+10.7 MHz
	MW2	531 to 1620 kHz	9 kHz	9 kHz	450 kHz
	LW	153 to 281 kHz	1 kHz	1 kHz	450 kHz
	SW	5940 to 6210 kHz	5 kHz	5 kHz	450 kHz

(2) Channel Selection Method (Sawtooth wave mode:)

- MANUAL Up/down
- SEEK Up/down
- SCAN 5-second hold (up only)
- Preset memory call by 1-button or 6-button method

(3) PRESET MEMORY

FM1	6 channels	} 24 channels in all
FM2	6 channels	
MW	6 channels	
LW (SW)	6 channels	

Last channel memory provided for each band

(4) LOC/DX, METAL, MONO/STEREO, LOUDNESS, DNR Control provided for each

(5) Control provided for SK search (Europe only)

(6) LCD display 1/2 duty, 1/2 bias

(7) On-chip frequency for tracking adjust

LC7020AK,7020BK

Package Dimensions
(unit: mm)

3057-Q64AIC

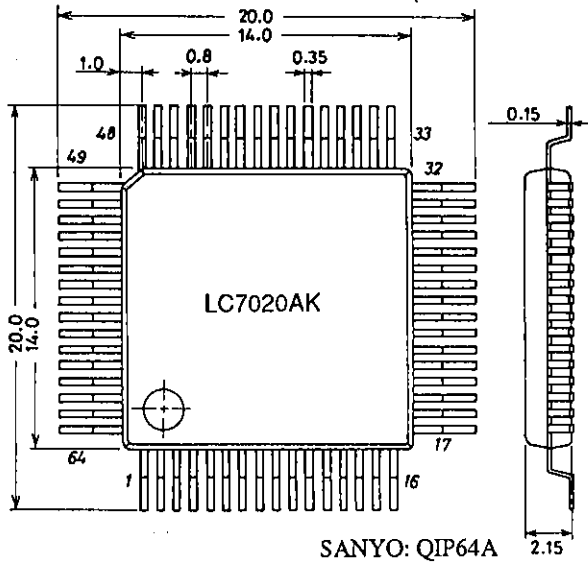

Package Dimensions
(unit: mm)

3026B-Q64BIC

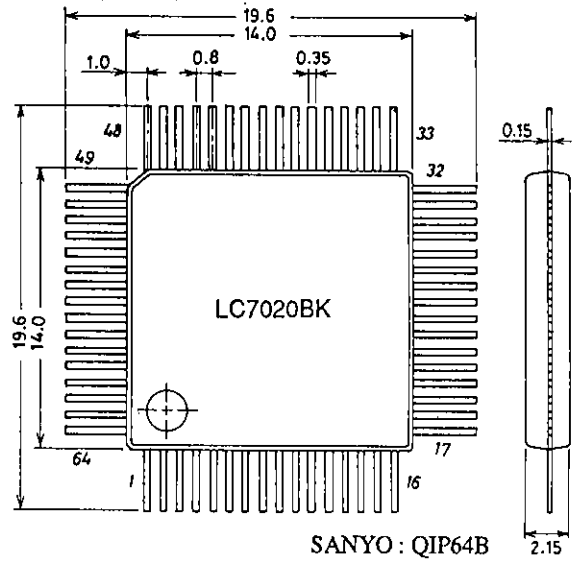

2. Pin Assignment

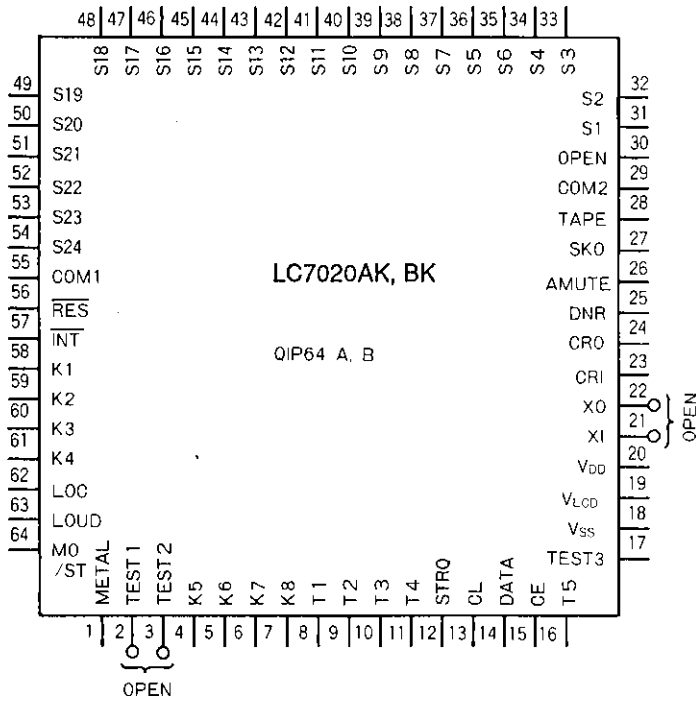

LC7020AK,7020BK

3. Main Specifications

Absolute Maximum Ratings /Ta = 25°C, V_{DD}=0V

Parameter	Symbol	Conditions/Pins		unit
Maximum Supply Voltage	V _{SS}		-5.5 to +0.3	V
Maximum Applied Voltage	V _{LCD}	V _{LCD}	-5.5 to +0.3	V
Maximum Input Voltage	V _{IN}	K1-K8, pins 12-15, $\overline{\text{INT}}$, $\overline{\text{RES}}$, TEST1-2, XI, CRI, pins 62-64, METAL, TAPE	V _{SS} -0.3 to +0.3	V
Maximum Output Voltage	V _{OUT}	Pins 8-11, 1, pins62-64, pins25-27, CRO, pins 12-15, XO, COM1, COM2, S1-S24	V _{SS} -0.3 to +0.3	V
Operating Temperature	T _{opr}		-30 to +70	°C
Storage Temperature	T _{stg}		-55 to +125	°C

Allowable Operating Conditions /Ta=-30 to +70°C, V_{DD}=0V

Parameter	Symbol	Conditions/Pins	min	typ	max	unit
Supply Voltage	V _{SS}		-5.25		-3.5	V
"H"-Level Input Voltage	V _{IH1}	{K1-8, $\overline{\text{INT}}$, TAPE	0.3V _{SS}		0	V
"L"-Level Input Voltage	V _{IL1}		V _{SS}		0.7V _{SS}	V
"H"-Level Input Voltage	V _{IH2}	{ $\overline{\text{RES}}$	0.25V _{SS}		0	V
"L"-Level Input Voltage	V _{IL2}		V _{SS}		0.75V _{SS}	V
Operating Frequency	f _{opg}	V _{SS} =-5.25 to -3.5V CRI, CRO CF400kHz version, Fig. 1	390	400	410	kHz

Electrical Characteristics/Ta=-30 to +70°C, V_{DD}=0V

Parameter	Symbol	Conditions/Pins	min	typ	max	unit
Input Resistance 1	R _{IN1}	V _{SS} =-2.9V K1-K8 pull-down Tr V _{IN} =V _{DD}	200		2000	kΩ
Input Resistance 2	R _{IN2}	V _{SS} =-2.9V TEST1, TEST2	10		400	kΩ
"H"-Level Output Voltage	V _{OH1}	V _{SS} =-4V, T1-T5, I _{OH} =-800μA	-0.5		V _{DD}	V
"L"-Level Output Voltage	V _{OL1}	V _{SS} =-4V, T1-T5, I _{OL} =800μA	V _{SS}		V _{SS} +0.5	V
"H"-Level Output Voltage	V _{OH2}	V _{SS} =-4V, 1, pins 62-64 I _{OH} =-200μA pins 12-15, pins 25-27	-0.5		V _{DD}	V
"L"-Level Output Voltage 2	V _{OL2}	V _{SS} =-4V, 1, pins 62-64 I _{OL} =200μA pins 12-15, pins 25-27	V _{SS}		V _{SS} +0.5	V
Segment driver output impedance						
"H"-Level Output Voltage 3	V _{OH3}	V _{SS} =-2.9V, S1-S24, I _{OH} =-0.4μA	-0.2		V _{DD}	V
"L"-Level Output Voltage 3	V _{OL3}	V _{SS} =-2.9V, S1-S24, I _{OL} =0.4μA	V _{SS}		V _{SS} +0.2	V
"H"-Level Output Voltage 4	V _{OH4}	V _{SS} =-2.9V, COM1, 2, I _{OH} =-4μA	-0.2		V _{DD}	V
"M"-Level Output Voltage	V _{OMH}	V _{SS} =-2.9V, COM1, 2, I _{OH} =-4μA	1/2V _{LCD}		1/2V _{LCD} +0.2	V
	V _{OML}	I _{OL} =4μA	1/2V _{LCD} -0.2		1/2V _{LCD}	V
"L"-Level Output Voltage 4	V _{OL4}	V _{SS} =-2.9V, COM1, 2, I _{OL} =4μA	V _{SS}		V _{SS} +0.2	V
Power Supply Leakage Current	I _{lek}	V _{SS} =-4V T _a =50°C		1	10	μA
Input Leakage Current	I _{Off}	K1-K8 $\overline{\text{INT}}$, $\overline{\text{RES}}$			1	μA
Current Dissipation	I _{DD}	V _{SS} =5V Ceramic resonator OSC, HALT mode 400kHz OSC Fig. 2			300	μA

Continued on next page.

Continued from preceding page.

Parameter	Symbol	Conditions/Pins	min	typ	max	unit
OSC Start Voltage	V_{start}	$T_{start} \leq 30ms$			-4	V
OSC Start Time	T_{start}	$V_{SS} = -4V$			30	ms
OSC Frequency	f_{OSC}	$V_{SS} = -5.25$ to $-4V$			420	kHz
$1/2V_{LCD}$ Voltage	V_M	$V_{LCD} = V_{SS} = -4V$ $V_O = 1/2V_{SS}$	-5	0	+5	%

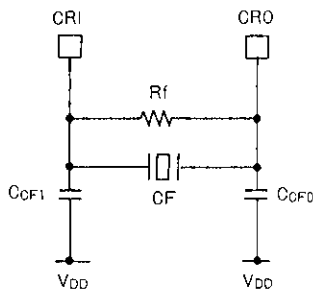

(CSB400P (Murata)
KBR400B (Kyocera))

Fig. 1 Ceramic Resonator OSC Circuit

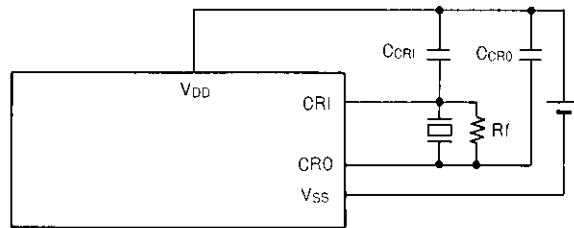

Fig. 2 OSC, Current Test Circuit in Hold Mode Test

■ No products described or contained herein are intended for use in surgical implants, life-support systems, aerospace equipment, nuclear power control systems, vehicles, disaster/crime-prevention equipment and the like, the failure of which may directly or indirectly cause injury, death or property loss.

■ Anyone purchasing any products described or contained herein for an above-mentioned use shall:

- ① Accept full responsibility and indemnify and defend SANYO ELECTRIC CO., LTD., its affiliates, subsidiaries and distributors and all their officers and employees, jointly and severally, against any and all claims and litigation and all damages, cost and expenses associated with such use:
- ② Not impose any responsibility for any fault or negligence which may be cited in any such claim or litigation on SANYO ELECTRIC CO., LTD., its affiliates, subsidiaries and distributors or any of their officers and employees jointly or severally.

■ Information (including circuit diagrams and circuit parameters) herein is for example only; it is not guaranteed for volume production. SANYO believes information herein is accurate and reliable, but no guarantees are made or implied regarding its use or any infringements of intellectual property rights or other rights of third parties.

4. Key Matrix

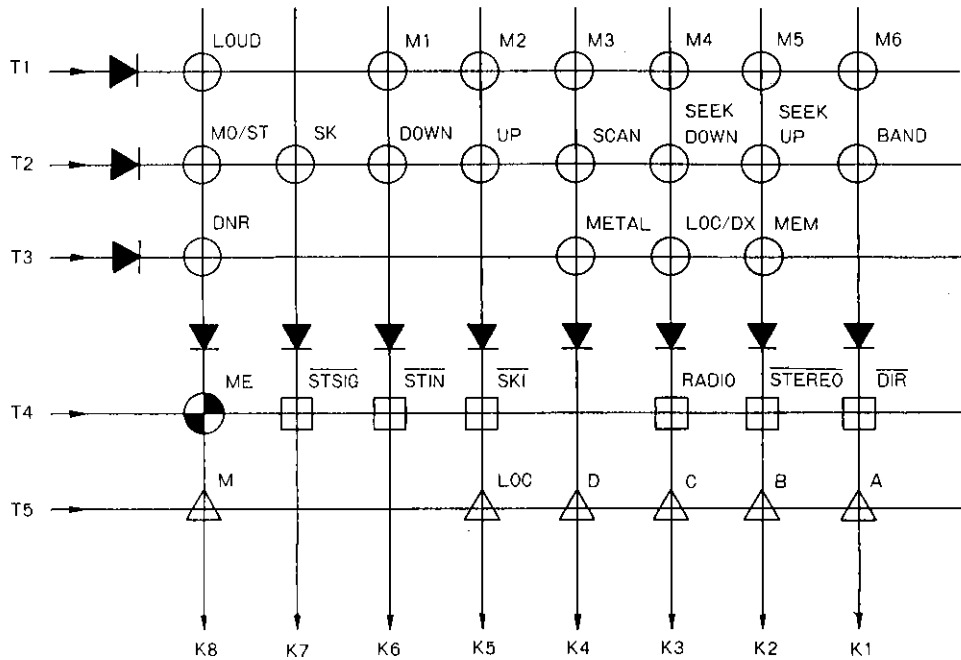

Note) T5 enters the read enable mode at the RADIO input-on state only.

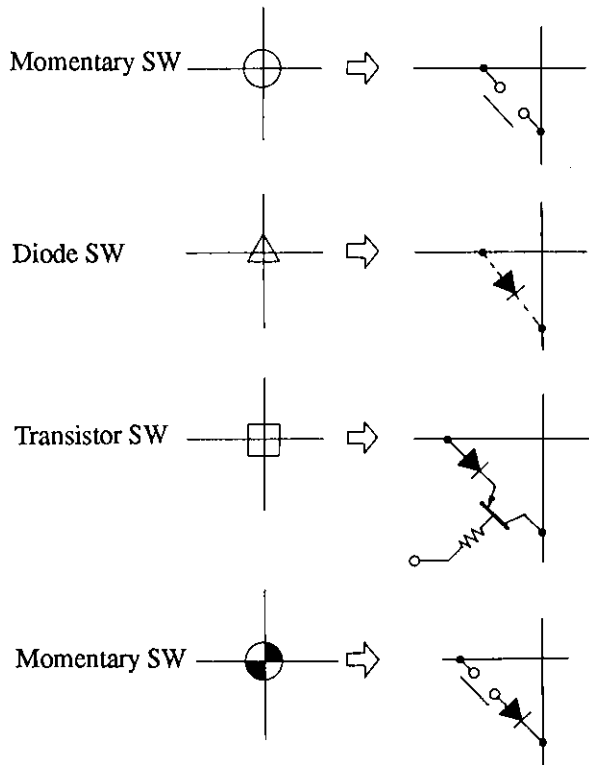

5. Diode Matrix (The read enable mode is entered at the RADIO input-on state only: "0": Without diode, "1": With diode)

(1) Area

D C B A	Area	
0 0 0 0	USA	FM1 (200KHz/step) MW1 (10kHz/step)
0 0 0 1		FM1,2 (100kHz/step) MW1 (10kHz/step)
0 0 1 0	Europe	FM1,2 (50KHz/step) MW2
0 1 0 0		FM1 (25kHz/step) MW2, LW
1 0 0 0		FM1 (25KHz/step) MW2
0 0 1 1		FM1 (25kHz/step) MW2, SW
0 1 1 0		FM1,2 (50kHz/step) MW2, LW
1 1 0 0	Japan	FM1,2 (100kHz/step) MW
0 1 0 1	USA	FM1,2 (200kHz/step) MW2 (9kHz/step)
1 0 1 0		FM1,2 (100kHz/step) MW2 (9kHz/step)

(2) Selection of preset memory call method

	1-button method	6-button method
M	1	0

(3) Selection of LOC/DX control method

LOC	0	1	
Item	"H"-level signal is delivered at the LOC pin during seeking/scanning at the LOC mode in each area.	USA Japan	FM use only. Operating the LOC/DX key provides LOC → "H", DX → "L". The indicator light goes on at the DX mode.
		Europe	The state set by the MO/ST key controls the LOC/DX pin. The indicator light goes on at the DX mode. "H"-level signal is delivered at the SEEK/SCAN mode only. No LOC/DX key provided. ST → LOC ("H"), MO → DX ("L"). FM use only.

6. Display

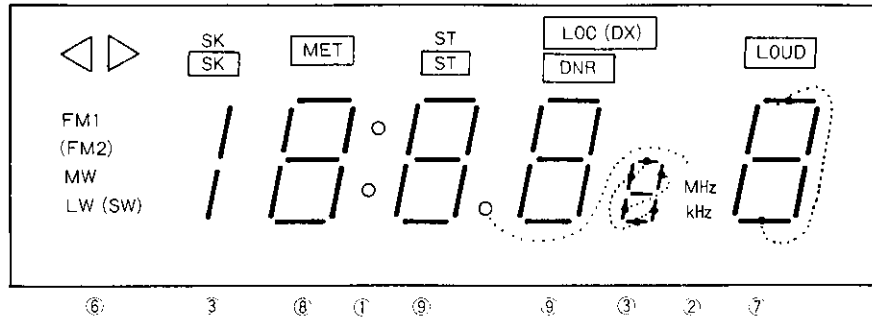

- FM2: Selected as required.
- LOC/DX: Either is selected.
- LW/SW: Either is selected.
- "SK" indicator light goes on when the \overline{SKI} is brought to "L" level. "ST" indicator light goes on when \overline{STEREO} is brought to "L" level.
- The LOC mode indicator light goes on when diode matrix LOC = 0. The DX mode indicator light goes on when diode matrix LOC = 1.

Display font 0 1 2 3 4 5 6 7 8 9

7. Key Description

- (1) M1-M6, MEM
Keys for writing in/calling from the preset memory. Each time the MEM key is pushed, the preset channel No. goes up by one.

6-button method

M1 - M6 key

Preset channel No.

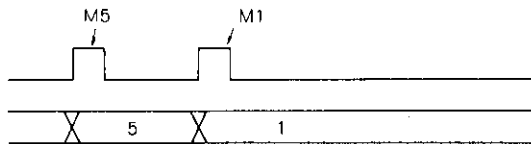

1-button method

MEM key

Preset channel No.

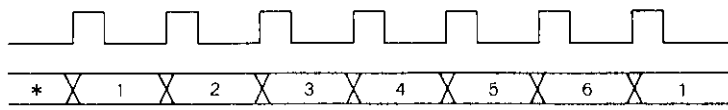

*: Preceding channel

- (2) ME
Used to write a new channel in the preset memory.
The write enable mode is released automatically 5 seconds after the ME key is pushed.
- (a) 6-button method (ME and M1-M6)
When the ME key is pushed, the preset channel display "-" (segment (g)) flashes and the write enable mode is entered; and when one of the M1-M6 keys is pushed within 5 seconds, a frequency displayed is written and a preset channel No. corresponding to this frequency is displayed.

ME key

Write enable

M1 - M6

Preset channel No.

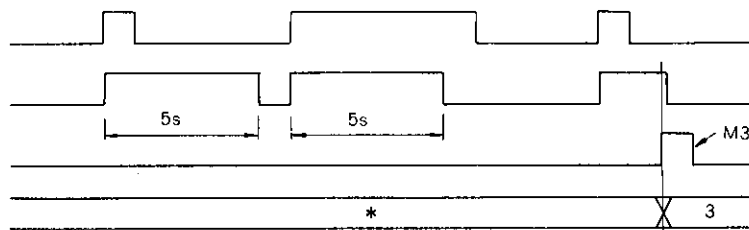

(b) 1-button method (ME and MEM)

When the ME key is pushed, a preset channel No. flashes (2Hz) and the write enable mode is entered (5 seconds); and when the MEM key is held pushed for 1.5 seconds or more, a frequency displayed is written. If the MEM key is released within 1.5 seconds, the next channel No. is read and the write enable mode (5 seconds) is updated at the same time.

Channel No. flashing is such that "*" flashes at the initial mode and last channel mode and a preset channel No. flashes at the preset channel read mode.

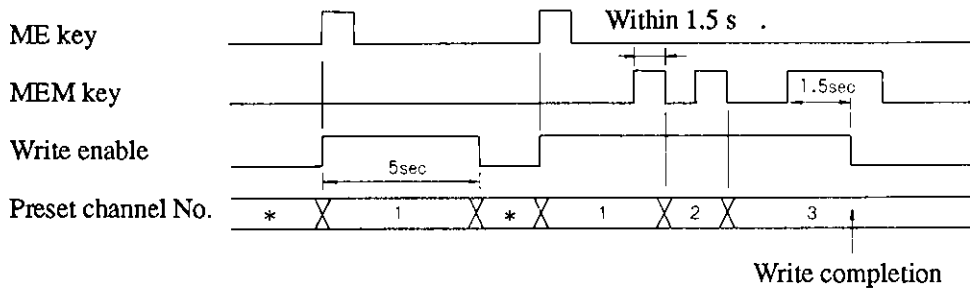

Frequency of * is written in channel "3".

(3) SCAN

Used to search a broadcasting station automatically and hold a receiving frequency for 5 seconds (AMUTE OFF) when the broadcasting station is reached. If this key is pushed again before lapse of 5 seconds, the receiving frequency continued to be held and then released. If nothing is done before lapse of 5 seconds, search starts again. When the SEEK key is pushed during scanning, the mode is changed to the seek mode. When the SEEK DOWN key is pushed during scanning, downward seek starts. The search rate is approximately 60 ms/step.

(4) UP, DOWN

Key for manual tuning. Each time this key is pushed, the channel No. goes up/down by one. When this key is held pushed for approximately 500 ms or more, the channel No. goes up/down at an approximately 60 ms/step. When switching between band edges occurs, the approximately 500 ms wait state is entered (see Timing (2)).

(5) BAND

Band select key. Each time this key is pushed, band switching occurs.

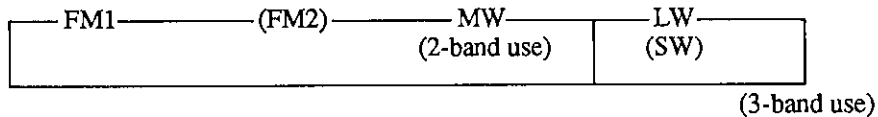

(6) SEEK UP, SEEK DOWN

Used to search a broadcasting station automatically and hold a receiving frequency. When the SCAN key is pushed during seeking, the mode is changed to the seek mode. Therefore, when the SCAN key is pushed during seeking-down, upward scan starts. When the SEEK DOWN (UP) key is pushed during seeking-up (down), downward (upward) seek starts. When the same key (SEEK UP or SEEK DOWN) is pushed twice, the search mode is released. The search rate is approximately 60 ms/step.

(7) LOC/DX

Effective in the RADIO mode only

Diode Matrix "LOC"	Display		Output	Description	
0	LOC		Lighted	H	"H"-level during seeking/scanning only at LOC mode*
			Unlighted	L	
1	USA Japan	DX	Lighted	L	FM use only. Operating the key causes the output to be inverted and fixed.
			Unlighted	H	
	Europe	DX	Lighted	L	The state set by the MO/ST key controls the LOC/DX pin. ST → LOC, MO → DX. FM use only. "H"-level during seeking/scanning only at LOC mode*
			Unlighted	H	

*: See Timing (4).

(8) LOUD

Key	Display		Output
LOUD	LOUD	Lighted	H
		Unlighted	L

(9) MO/ST
Effective for FM only

Mode	Key	Display		Output
RADIO	MO/ST	ST	Lighted	L
			Unlighted	H

Note) For the RADIO, TAPE mode, see 9. Operation of RADIO, TAPE Inputs.

(10) DNR, METAL

Mode	Key	Display		Output
TAPE	DNR	DNR	Lighted	H
			Unlighted	L
	METAL	METAL	Lighted	H
			Unlighted	L

(11) SK

This key is for FM use only in Europe. Each time this key is pushed, the SK mode is enabled/disabled. When "SK" indicator light is turned on, the SK mode is entered and the signal on the SKO pin becomes "H" level. In this case, the SK station can be seeked or scanned. Seeking/scanning stops only when the signals on the SKI, STSIG, and STIN (for the LM7001, SKI and STSIG) are at "L" level. "SK" indicator light, being for FM use in Europe, is turned on when the SKI pin input is at "L" level regardless of the SK mode.

Mode	Key	Display		Output
RADIO TAPE	SK	SK	Lighted	H
			Unlighted	L

Sample Connections with Traffic Information-Use IC

Ex. 1. Connection with LA2200

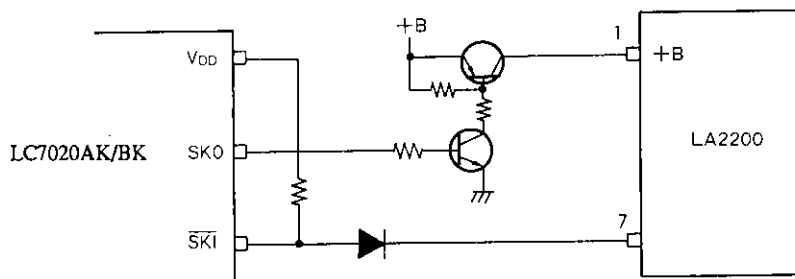

Ex. 2. Connection with LA2220

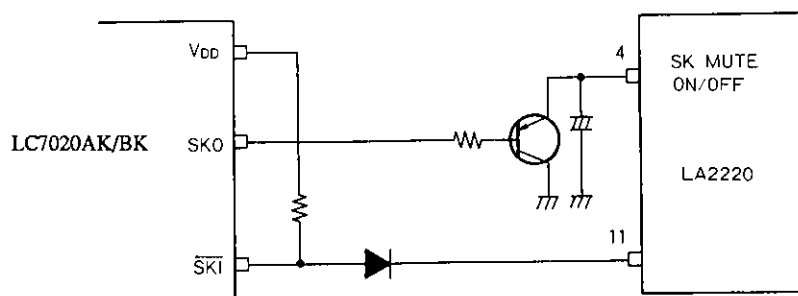

8. Timing Description

(1) Seek, Scan

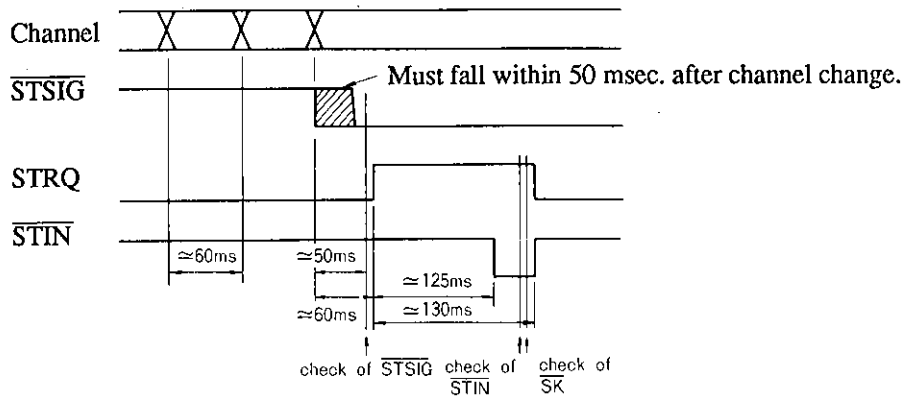

(2) Manual

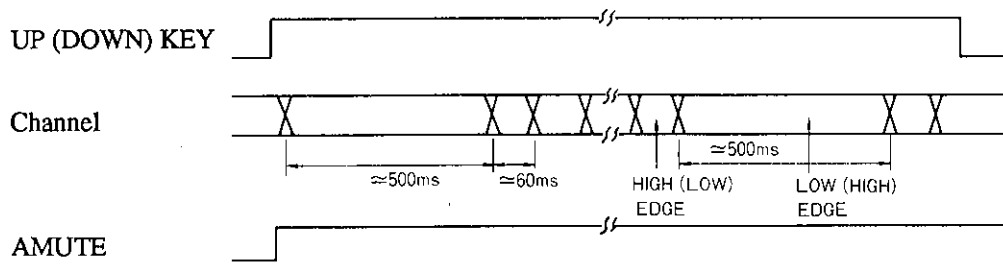

(3) RADIO input-on

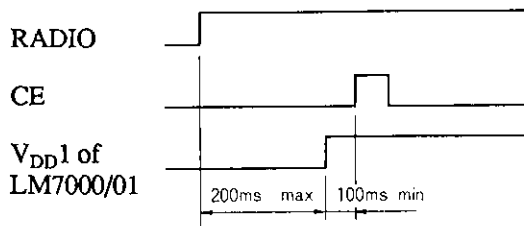

(4) LOC mode (Diode matrix "LOC"=0, or LOC=1 in Europe)

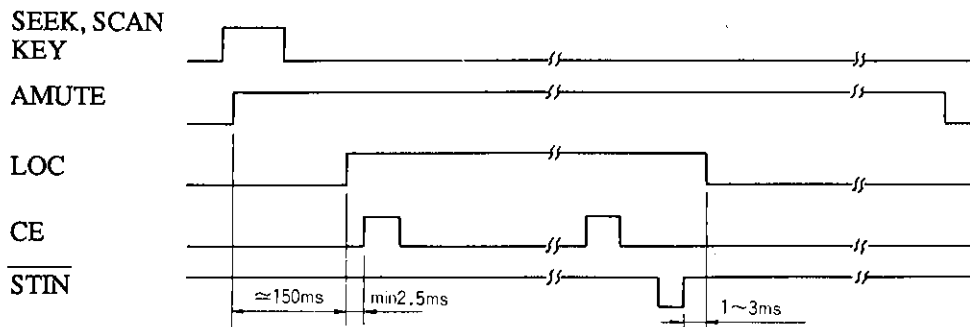

(5) Audio mute (AMUTE)

- 1) Key chattering eliminating time (approximately 10 to 20 ms)
- 2) Audio pre-mute time (approximately 15 msec.) 150 to 160 ms at seek/scan mode only
- 3) Data transfer to PLL (50 to 100 msec.)
- 4) Audio post-mute time

(a) Band select mode, preset channel read mode

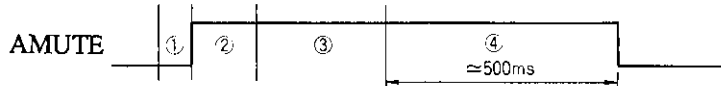

(b) Manual up/down mode

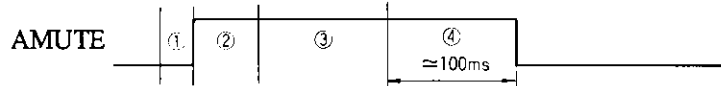

(c) Seek/scan mode

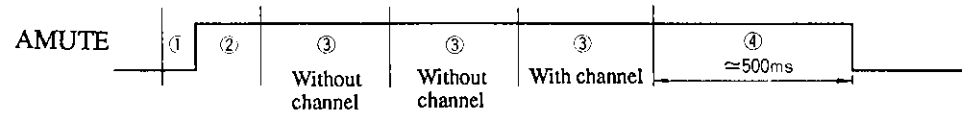

(d) RADIO, TAPE-on/off mode

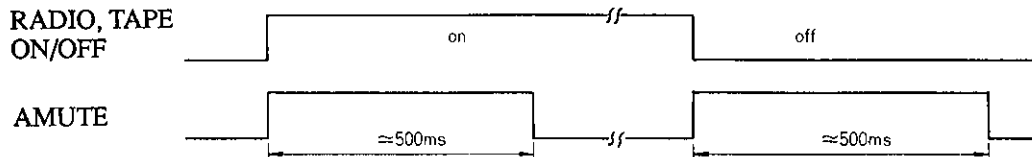

(e) Initial power-on mode

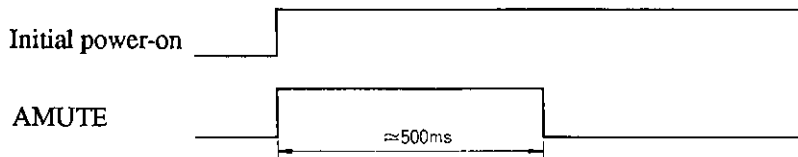

LC7020AK,7020BK

- (6) **Hold mode**
When the TAPE, RADIO inputs are (0, 0), the hold mode is entered.

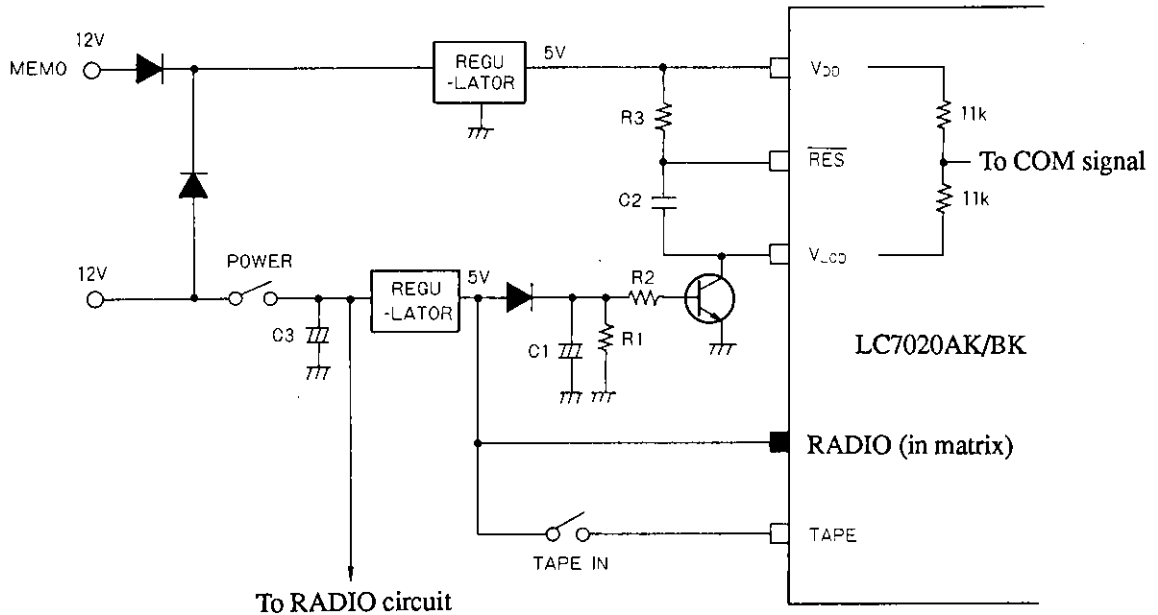

Unit (resistance: Ω)

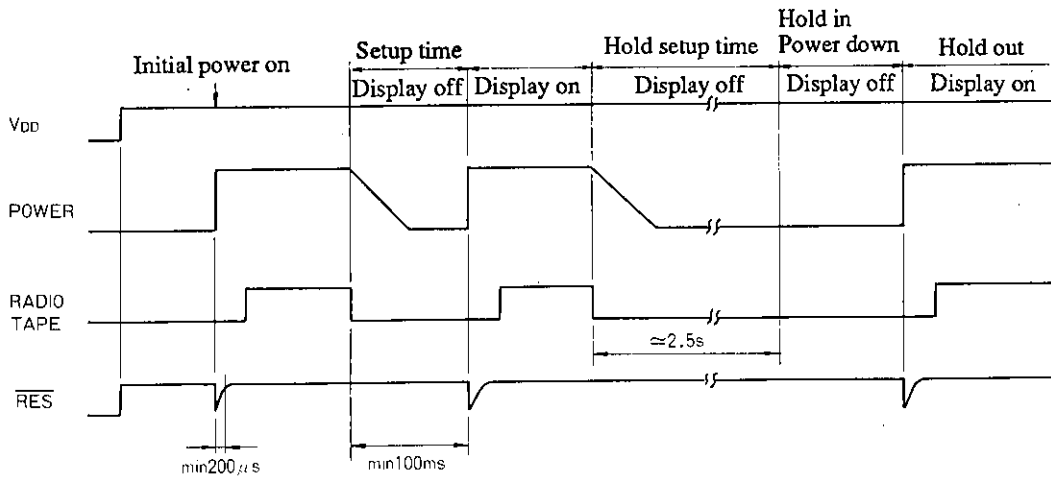

If the $\overline{\text{RES}}$ signal is applied within 100 ms after the RADIO input becomes "0", the normal operation may not be performed. C_1 , R_1 , and R_2 must be connected to hold the $\overline{\text{RES}}$ signal from being delivered within 100 ms after the POWER switch is turned off.

The hold mode is entered when 2.5 sec. setup time has elapsed after RADIO, TAPE inputs = (0, 0). Therefore, C_1 and C_3 must finish discharging within 2.5 s.

- Hold time provided by C_1 , R_1 , R_2 after POWER switch off > 100 ms
- (Hold time provided by C_1 , R_1 , R_2 after POWER switch off) + (C_3 discharging time) < 2.5 s

It should be noted that when the $\overline{\text{RES}}$ signal (may be accepted in less than 200 μ s) is applied during the normal operation (RADIO, TAPE inputs = other than (0, 0)) a malfunction may occur.

9. Operation of RADIO, TAPE Inputs

Spec. for a Set (Note 3)	RADIO Input	TAPE Input	Mode	Display	Key Operation (Note 1)
With tape, radio	0	0	Memory hold	None	All keys invalid
With tape, radio	0	1	TAPE	For TAPE only	B
With tape, radio	1	0	RADIO	For RADIO only	C
Traffic information (with SK)	1 (Note 4)	1 (Note 4)	TAPE RADIO	For TAPE and RADIO Always lighted	B, C SK Key

(Note 1) B: Keys related to TAPE DNR, METAL, LOUD are valid.
 C: Keys related to RADIO BAND, M1 to M6, MEM, UP, DOWN, SEEK UP, SEEK DOWN, SCAN, MO/ST, LOC/DX, LOUD, CL/FRQ are valid.

(Note 3) Sample connections (set use) with RADIO, TAPE inputs

(a) Normal (with radio, tape)

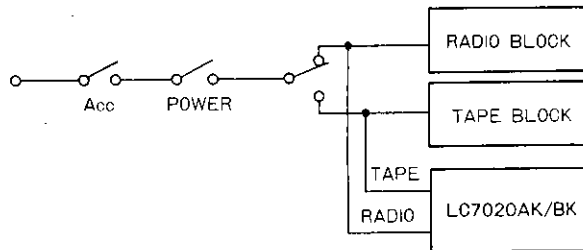

(b) Traffic information (with radio, tape)

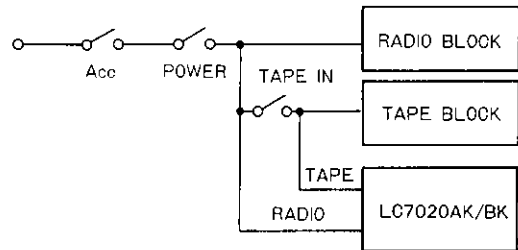

TAPE mode → RADIO mode

The TAPE signal must not fall within 125 ms after the RADIO signal rises.

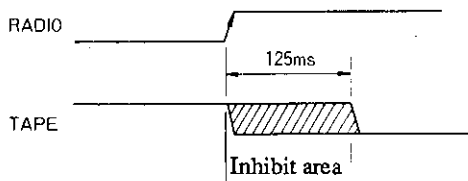

The RADIO mode and TAPE mode are entered simultaneously.

The TAPE signal must fall within 125 ms after the RADIO signal rises.

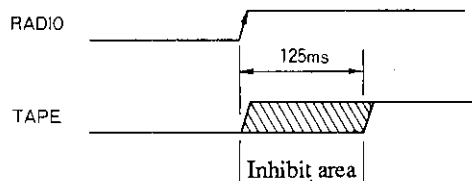

(Note 4) The Europe version only can be used in this mode.

10. Initial Mode

<RADIO mode>

- Band : FM1
- MO/ST : MONO
- SK : SK mode off
- LOC/DX : DX

<TAPE mode>

- DNR : OFF
- METAL : OFF

<Other>

- LOUD : OFF

11. Pin Description

Pin Name	Pin No.	Description	Active	I/O	I/O Configuration
METAL	1	Output signal for turning on/off equalizer for metal tape Operates at the TAPE mode.	H	O	B
TEST1 TEST2 TEST3	2 3 17	LSI test pins. Must be left open.	-	-	-
K5 to K8 K1 to K4	4 to 7 58 to 61	Key input signal	H	I	A
T1 to T4	8 to 11	Key scan signal (approximately 77Hz)	H	O	B
T5	16	Diode matrix scan signal RADIO signal "0" → "1" causes a scan.	H	O	B
STRQ	12	Signal for instructing the LM7000 to count IF	H	O	B
CE	15	Data signal to be transferred CE: Chip enable to the LM7000/01.	H	O	B
CL	13	CL: Sync clock			
DATA	14	DATA: Transfer data	-		
V _{DD} , V _{SS}	20, 18	Application of power, V _{DD} = 5V, V _{SS} = 0V	-	-	-
V _{LCD}	19 21, 22	When the LCD drive supply is used to turn on the indicator light, 0V. For power save (hold) at the light turned-off mode, leave this pin open.	-	I	E
XI, XO		32kHz crystal OSC pin. Must be left open.	-	-	-
CRI	23	The system clock (400kHz) from the LM7000/01 is applied to the CRI or a ceramic resonator is connected across CRI and CRO.	-	I	C
CRO	24			O	
TAPE	28	Input signal to cause the tape mode to be entered (Refer to "9. Operation of RADIO, TAPE Inputs".)	H	I	A
COM1 COM2	55 29	Output pins for common plate (COM) of LCD panel Frame frequency: 100Hz, drive: 1/2 duty	-	O	D
S1 to S24	31 to 54	Output pins for LCD panel segments	-	O	B
RES	56	Input pin for resetting the LSI system	L	I	A
INT	57	Connected to V _{DD}	L	I	A
LOC	62	Output signal for selecting LOC/DX. Depends on the state of the diode matrix. Refer to "7. Key Description".	H	O	B
LOUD	63	Output pin for loudness control	H	O	B
MO/ST	64	Output signal for selecting monaural (H)/stereo (L) (For RADIO mode only)	L	O	B
DNR	25	Output pin for DNR control (For TAPE mode only)	H	O	B

Continued on next page.

LC7020AK, 7020BK

Continued from preceding page.

Pin Name	Pin No.	Description	Active	I/O	I/O Configuration
AMUTE	26	Audio mute signal to be delivered at the following mode. <ul style="list-style-type: none"> • Band select mode • Manual up/down mode • Seek, scan mode • Reset channel read mode • RADIO or TAPE on/off mode • Initial power-on mode 	H	O	B
SKO	27	SK mode output signal	H	O	B

12. Description of Transistor Matrix Input

Input Pin Name	Description	Remarks
$\overline{\text{STIN}}$	Automatic tuning stop signal used when the IF count mode is used with the LM7000 Active "L"	When no IF count mode is used, no Tr is required, but the Di is required.
$\overline{\text{STSIG}}$	Signal for giving information that a broadcasting station is nearby during automatic tuning when the IF count mode is used with the LM7000. Used as the station detector signal (SD signal) when no IF count mode is used (when the LM7001 is used) Active "L"	
RADIO	Signal for causing the RADIO mode to be entered (Refer to "9. Operation of RADIO, TAPE Inputs".) Active "H"	
$\overline{\text{SKI}}$	SK signal input for FM use only in Europe. "SK" indicator light is held turned on when the SKI is at "L" level. (Refer to "7. Key Description".) Active "L"	Each pin is sampled with a period of approximately 13 ms to cause the indicator light to go on/off.
$\overline{\text{STEREO}}$	STEREO signal. "ST" indicator light is turned on when the STEREO is brought to "L". Active "L"	
$\overline{\text{DIR}}$ signal	$\overline{\text{DIR}}$ signal $\begin{cases} \rightarrow \text{"H" causes } \blacktriangleright \text{ indicator light to go on.} \\ \leftarrow \text{"L" causes } \blacktriangleleft \text{ indicator light to go on.} \end{cases}$	

The transistor base provides the active polarity for signal.

Pin Input/output configuration

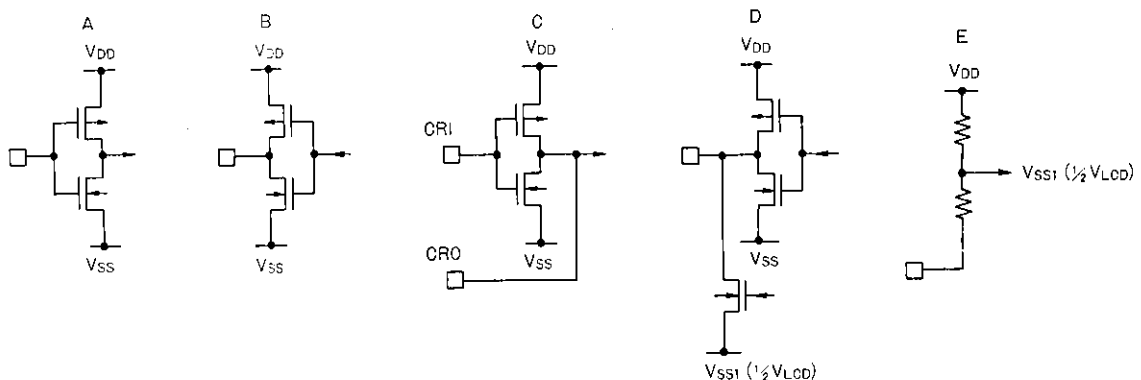

LC7020AK, 7020BK

13. Tracking Point

The following frequencies are loaded in each memory at the initial power-on mode.

Unit $\left\{ \begin{array}{l} \text{FM (MHz)} \\ \text{Others (kHz)} \end{array} \right\}$

Area	Band	M1	M2	M3	M4	M5	M6
Japan	FM1	76.0	78.6	83.0	86.6	90.0	76.0
	MW	522	612	999	1404	1629	522
USA	FM1	87.5	90.1	98.1	106.1	107.9	87.5
	MW1	530	610	1000	1400	1620	530
	MW2	531	612	999	1404	1620	531
Europe	FM1	87.5	90.0	98.0	106.0	108.0	87.5
	MW2	531	612	999	1404	1620	531
	LW	153	160	200	260	281	153
	SW	5940	6000	6100	6200	6210	5940

14. Band Power Supply Select Signal (Refer to Sample Application Circuits.)

This signal is delivered at the B01 to B03 of the LM7000/01.

The output is of the N-ch open drain type.

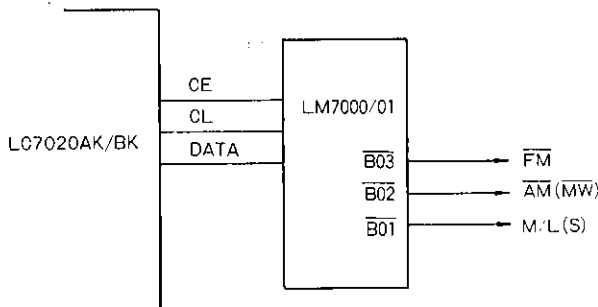

Band	FM	AM	M/L (S)
FM	L	H	H
MW	H	L	H
LW or SW	H	L	L

15. SW Specification

The SW VCO output signal must be applied to the FMIN pin of the LM7000/01.

16. Panel and Connection of Segment, Common Pins

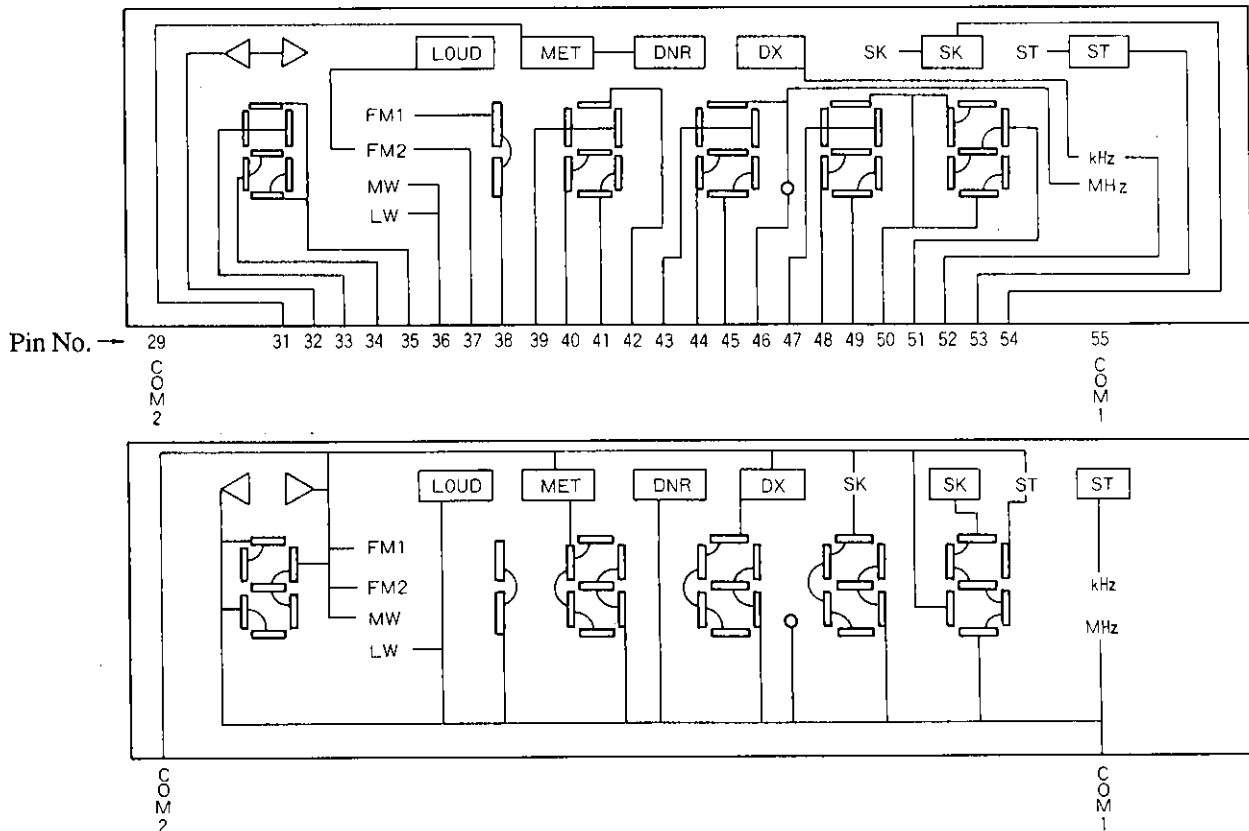

17. Notes for Car System Design

A reduced voltage is inevitable to car systems. To operate the controller reliably even at a reduced voltage, the constant-voltage circuit of low-saturation type shown below is required.

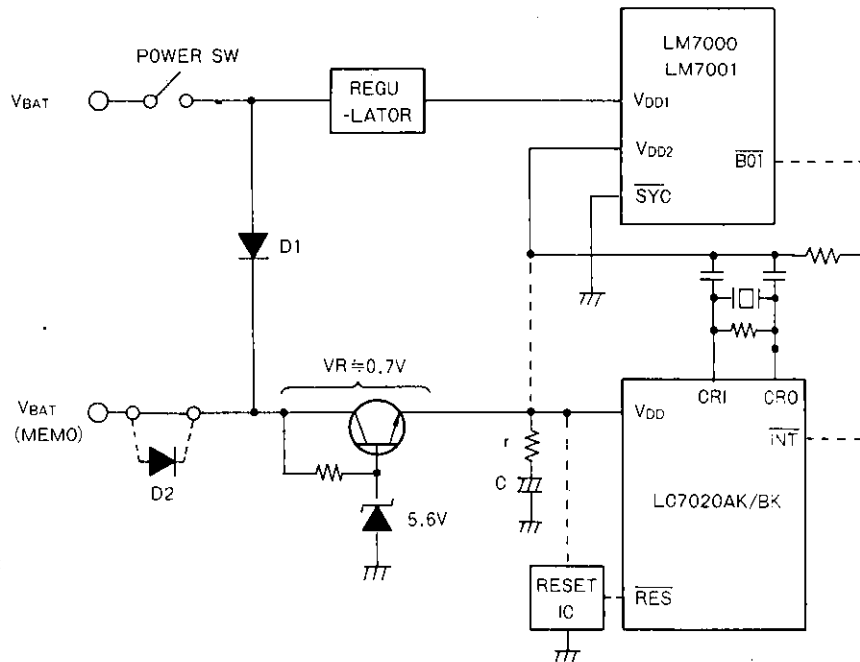

Assuming that a reduced voltage occurs instantaneously, a capacitor for V_{DD} hold must be connected additionally (r is used to limit the inrush current). If it is assumed that even the circuit shown above provides a voltage less than the allowable operating voltage of the LC7020AK/BK, LM7000/01, the RESET IC must be connected additionally to reset the LC7020AK/BK.

In the recommended circuit shown above,

(1) To what extent may the voltage be reduced?

- (a) When the ceramic resonator OSC mode is used for generation of the LC7020AK/BK system clock:
Allowable operating voltage V_{DD} min of the LC7020AK/BK is 3.5V.

$$V_{BAT} - V_R \geq 3.5V$$

If $V_R = 0.7V$

$$V_{BAT} \geq 3.5 + 0.7 = 4.2V$$

The V_{BAT} down to 4.2V is allowable at the reduced voltage mode.

(Note) When the D2 that acts to provide protection against inverted connection, the V_{BAT} down to 4.9V is allowable (V_F of D2 is 0.7V).

(2) About capacitance of C

- When the ceramic resonator OSC mode is used for generation of the LC7020AK/BK system clock:
Fix the capacitance with the holding time and the current dissipation of the LC7020AK/BK considered.

(3) About RESET IC

- When the ceramic resonator OSC mode is used for generation of the LC7020AK/BK system clock:
Connect the RESET IC additionally so that the LC7020AK/BK is reset when the V_{DD} becomes 3.5V.

(Note) The D1 acts to prevent malfunction which will occur when connection to the V_{BAT} and V_{BAT} (MEMO) is made wrongly.

Sample Application Circuit 2 (Applicable In all areas)
LC7020AK/BK, LM7001 System

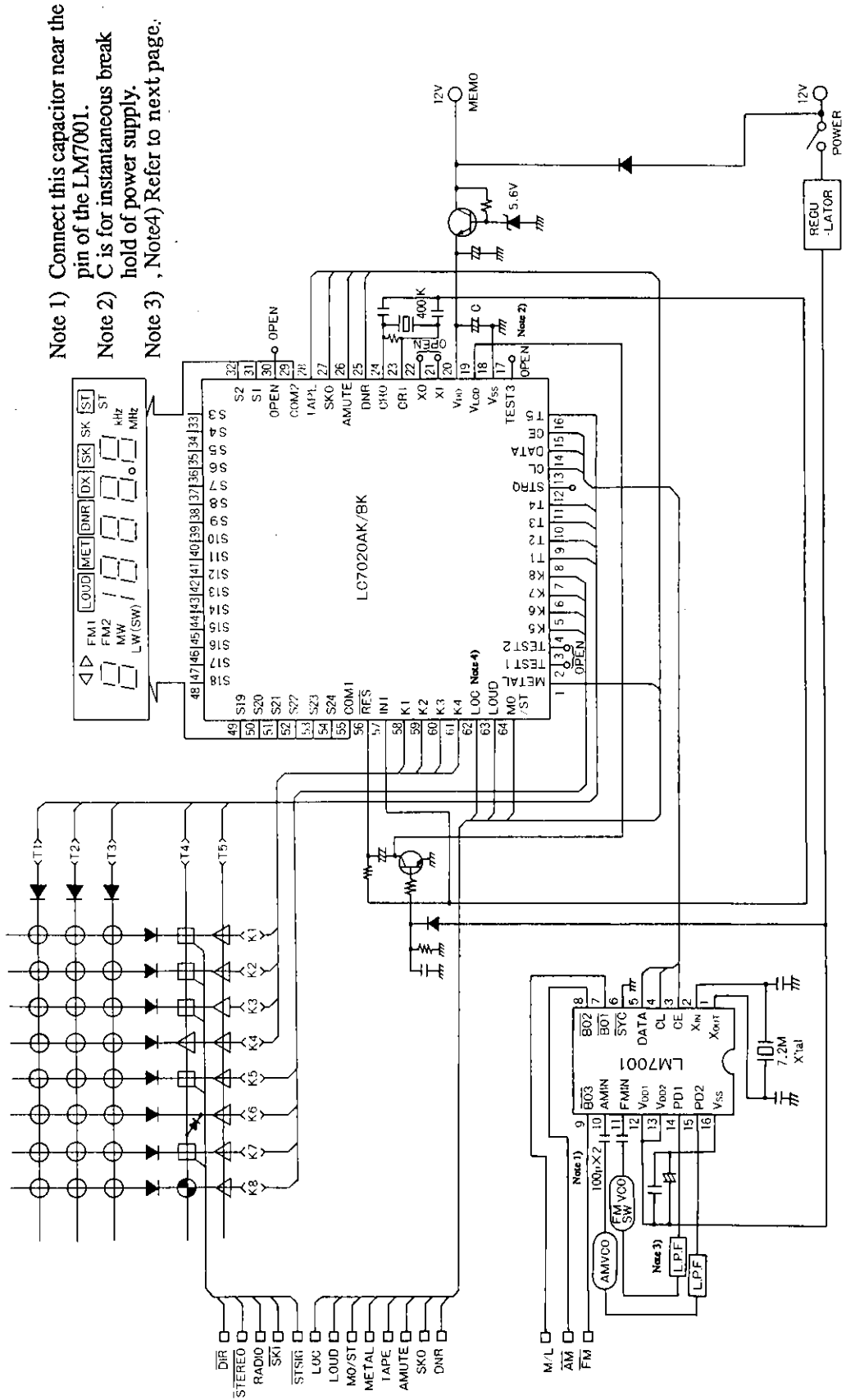

- Note 1) Connect this capacitor near the pin of the LM7001.
- Note 2) C is for instantaneous break hold of power supply.
- Note 3) , Note4) Refer to next page.

Note: The Sample Application Circuits and Circuit Constants herein do not assume designs for mass production to be made with the deviation and temperature characteristics of the parts in mind and provide no guarantee for designing sets.

Unit (capacitance: F)

LC7020AK,7020BK

Continued from preceding page.

Note 3) If both FM and AM are the same in the constants of the low-pass filter, no more than one low-pass filter is required.

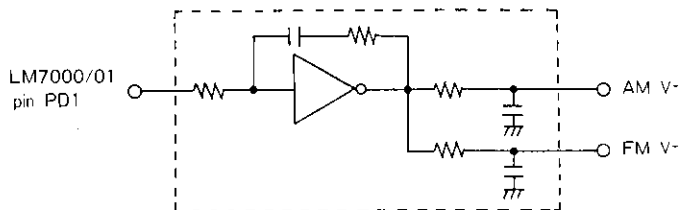

Place the parts bounded by the dotted line near the LM7000, LM7001.

Note 4) If a noise is generated at this pin, take the following measure.

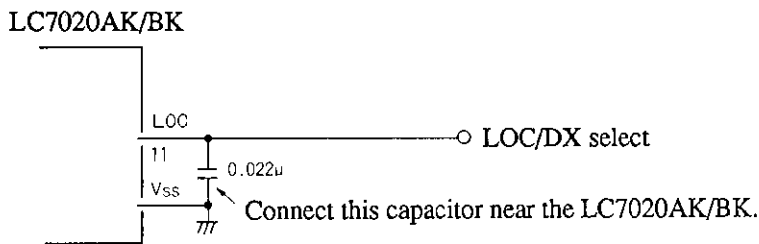

Note 5) When no IF count mode is used: (Using the LM7000)

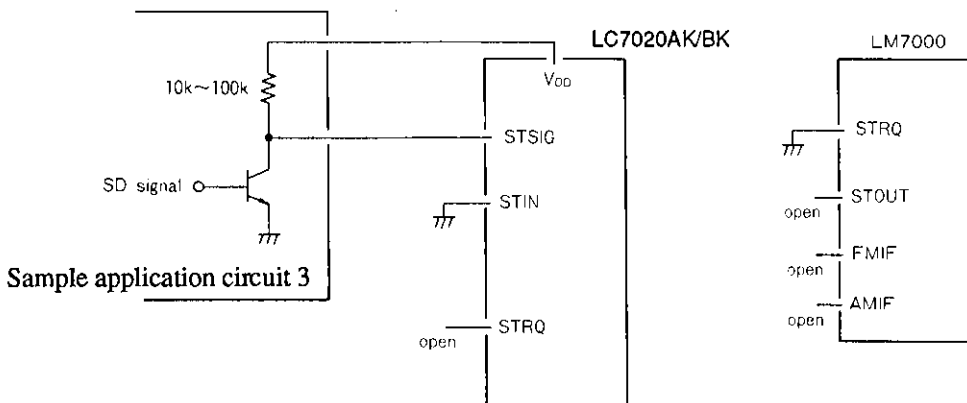

Unit (resistance: Ω, capacitance: F)

Sample Application Circuit 4

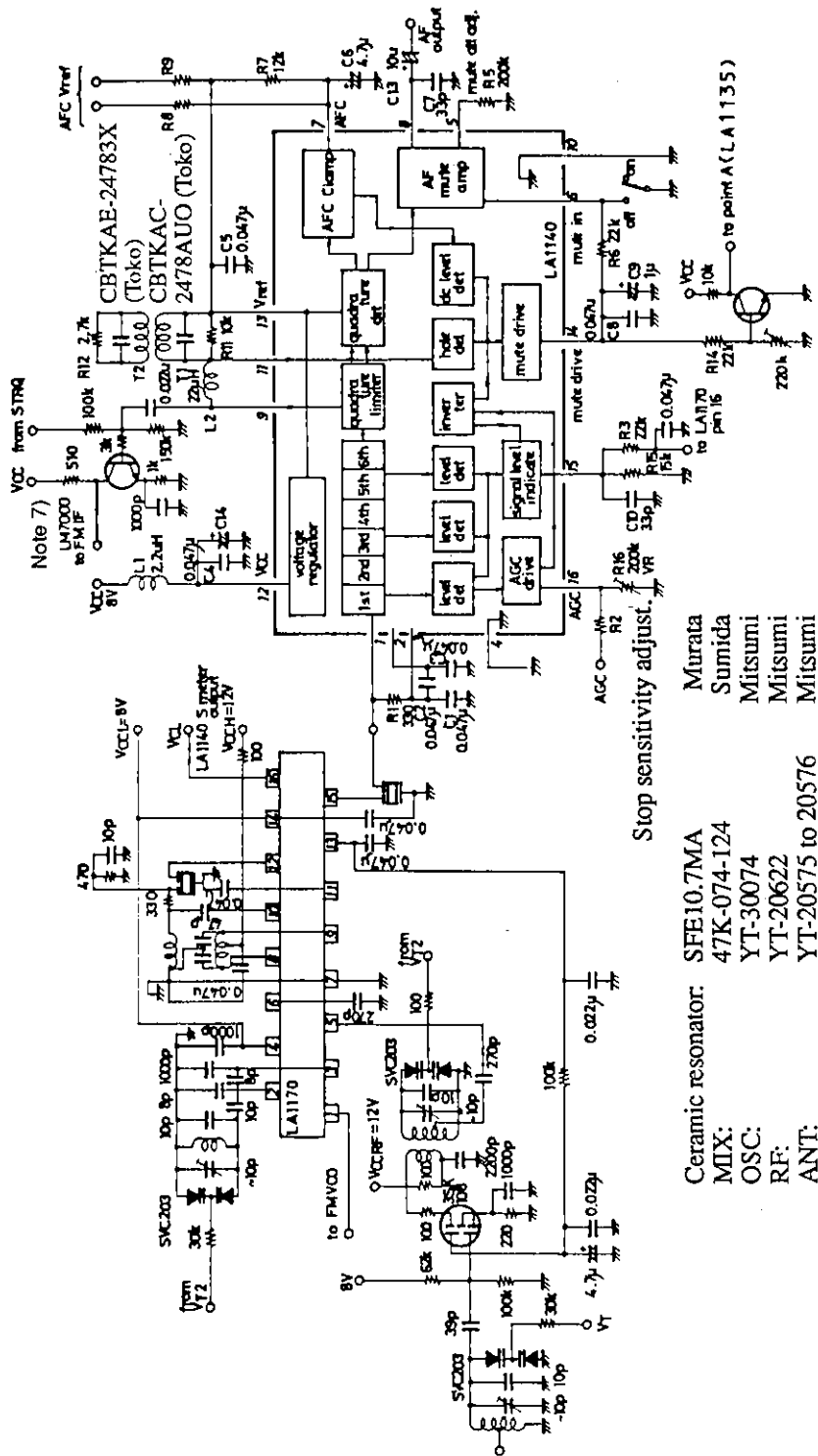

Unit (resistance: Ω, capacitance: F)

Note 7) When the STRQ pin is brought to high level at the AM mode, the IF signal of AM must maintain the following level.

