

isc Silicon NPN Power Transistor

2SD843

DESCRIPTION

- High Collector Current: $I_C = 7A$
- Low Collector Saturation Voltage
: $V_{CE(sat)} = 0.5V(Max) @ I_C = 4A$
- High Collector Power Dissipation
- Complement to Type 2SB753

APPLICATIONS

- High current switching applications
- Power amplifier applications.

ABSOLUTE MAXIMUM RATINGS($T_a=25^\circ C$)

SYMBOL	PARAMETER	VALUE	UNIT
V_{CBO}	Collector-Base Voltage	100	V
V_{CEO}	Collector-Emitter Voltage	80	V
V_{EBO}	Emitter-Base Voltage	5	V
I_C	Collector Current-Continuous	7	A
P_C	Collector Power Dissipation @ $T_a=25^\circ C$	1.5	W
	Total Power Dissipation @ $T_C=25^\circ C$	40	
T_J	Junction Temperature	150	$^\circ C$
T_{stg}	Storage Temperature Range	-55~150	$^\circ C$

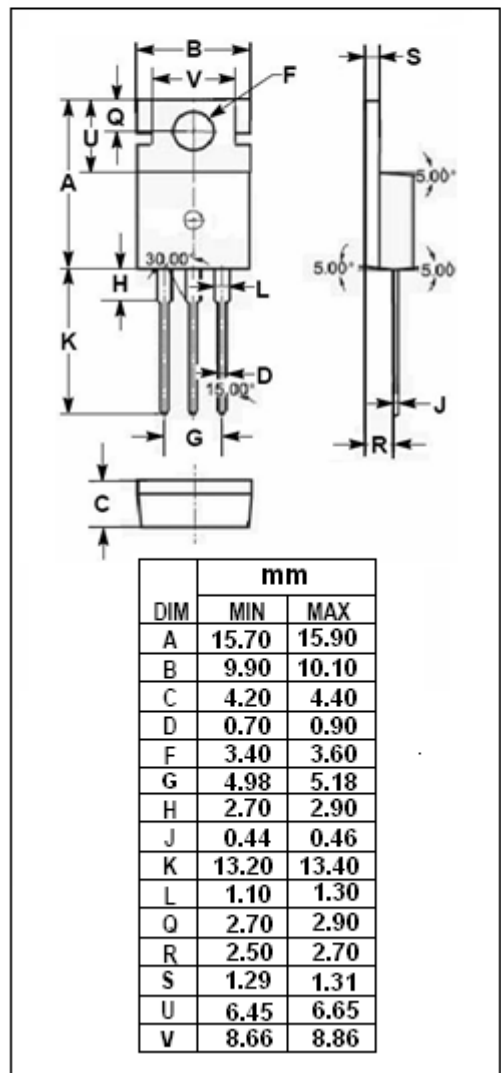
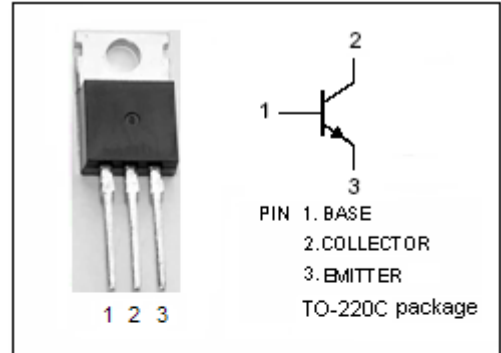

isc Silicon NPN Power Transistor

2SD843

ELECTRICAL CHARACTERISTICS

 $T_C=25^{\circ}\text{C}$ unless otherwise specified

SYMBOL	PARAMETER	CONDITIONS	MIN	TYP.	MAX	UNIT
$V_{(BR)CEO}$	Collector-Emitter Breakdown Voltage	$I_C=50\text{mA}; I_B=0$	80			V
$V_{CE(sat)}$	Collector-Emitter Saturation Voltage	$I_C=4\text{A}; I_B=0.4\text{A}$			0.5	V
$V_{BE(sat)}$	Base-Emitter Saturation Voltage	$I_C=4\text{A}; I_B=0.4\text{A}$			1.4	V
I_{CBO}	Collector Cutoff Current	$V_{CB}=100\text{V}; I_E=0$			5	μA
I_{EBO}	Emitter Cutoff Current	$V_{EB}=5\text{V}; I_C=0$			5	μA
h_{FE-1}	DC Current Gain	$I_C=1\text{A}; V_{CE}=1\text{V}$	70		240	
h_{FE-2}	DC Current Gain	$I_C=4\text{A}; V_{CE}=1\text{V}$	30			
f_T	Current-Gain—Bandwidth Product	$I_C=1\text{A}; V_{CE}=4\text{V}$		10		MHz
C_{OB}	Output Capacitance	$I_E=0; V_{CB}=10\text{V}; f_{\text{test}}=1\text{MHz}$		250		pF

Switching times

t_{on}	Turn-on Time	$R_L=10\Omega, V_{CC}=30\text{V}$ $I_{B1}=-I_{B2}=0.3\text{A}$		0.4		μs
t_{stg}	Storage Time			2.5		μs
t_f	Fall Time			0.5		μs

◆ h_{FE-1} Classifications

O	Y
70-140	120-240