

Silicon NPN Power Transistors

BD245/A/B/C

DESCRIPTION

- With TO-3PN package
- Complement to type BD246/A/B/C

APPLICATIONS

- For use in medium power linear and switching applications

PINNING

PIN	DESCRIPTION
1	Base
2	Collector;connected to mounting base
3	Emitter

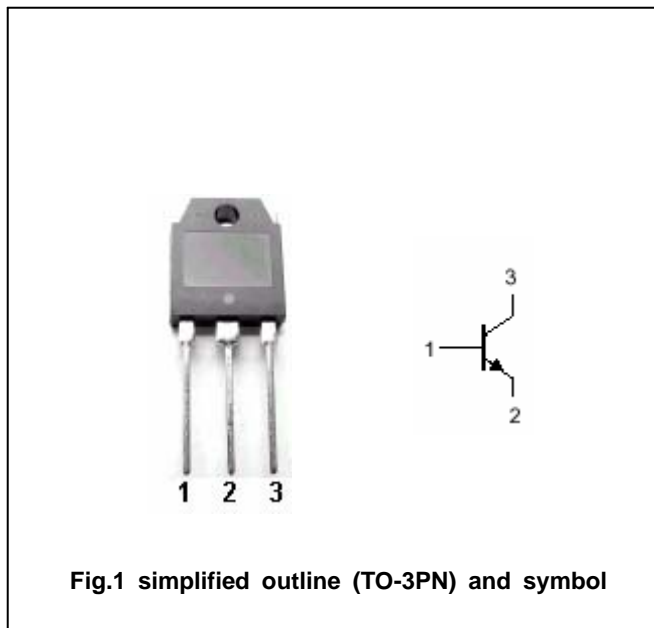

Fig.1 simplified outline (TO-3PN) and symbol

Absolute maximum ratings(Ta=)

SYMBOL	PARAMETER	CONDITIONS	VALUE	UNIT
V _{CBO}	Collector-base voltage	BD245	55	V
		BD245A	70	
		BD245B	90	
		BD245C	115	
V _{CEO}	Collector-emitter voltage	BD245	45	V
		BD245A	60	
		BD245B	80	
		BD245C	100	
V _{EBO}	Emitter-base voltage	Open collector	5	V
I _C	Collector current		10	A
I _{CM}	Collector current-peak		15	A
I _B	Base current		3	A
P _C	Collector power dissipation	T _C =25	80	W
T _j	Junction temperature		-65~150	
T _{stg}	Storage temperature		-65~150	

THERMAL CHARACTERISTICS

SYMBOL	PARAMETER	VALUE	UNIT
R _{th j-c}	Thermal resistance junction to case	1.56	/W

Silicon NPN Power Transistors

BD245/A/B/C

CHARACTERISTICS

T_j=25 unless otherwise specified

SYMBOL	PARAMETER		CONDITIONS	MIN	TYP.	MAX	UNIT
V _{CEO(BR)}	Collector-emitter breakdown voltage	BD245	I _C =30mA ; I _B =0	45			V
		BD245A		60			
		BD245B		80			
		BD245C		100			
V _{CEsat-1}	Collector-emitter saturation voltage		I _C =3A ; I _B =0.3A			1.0	V
V _{CEsat-2}	Collector-emitter saturation voltage		I _C =10A ; I _B =2.5A			4.0	V
V _{BE-1}	Base-emitter on voltage		I _C =3A ; V _{CE} =4V			1.6	V
V _{BE-2}	Base-emitter on voltage		I _C =10A ; V _{CE} =4V			3.0	V
I _{CEO}	Collector cut-off current	BD245/245A	V _{CE} =30V ; I _B =0			0.7	mA
		BD245B/245C	V _{CE} =60V ; I _B =0				
I _{EBO}	Emitter cut-off current		V _{EB} =5V ; I _C =0			1.0	mA
h _{FE-1}	DC current gain		I _C =1A ; V _{CE} =4V	40			
h _{FE-2}	DC current gain		I _C =3A ; V _{CE} =4V	20			
h _{FE-3}	DC current gain		I _C =10A ; V _{CE} =4V	4			

Switching times

t _{on}	Turn-on time	I _C =1A; I _{B1} =-I _{B2} =0.1A R _L =20		0.3		μs
t _{off}	Turn-off time			1.0		μs

Silicon NPN Power Transistors

BD245/A/B/C

PACKAGE OUTLINE

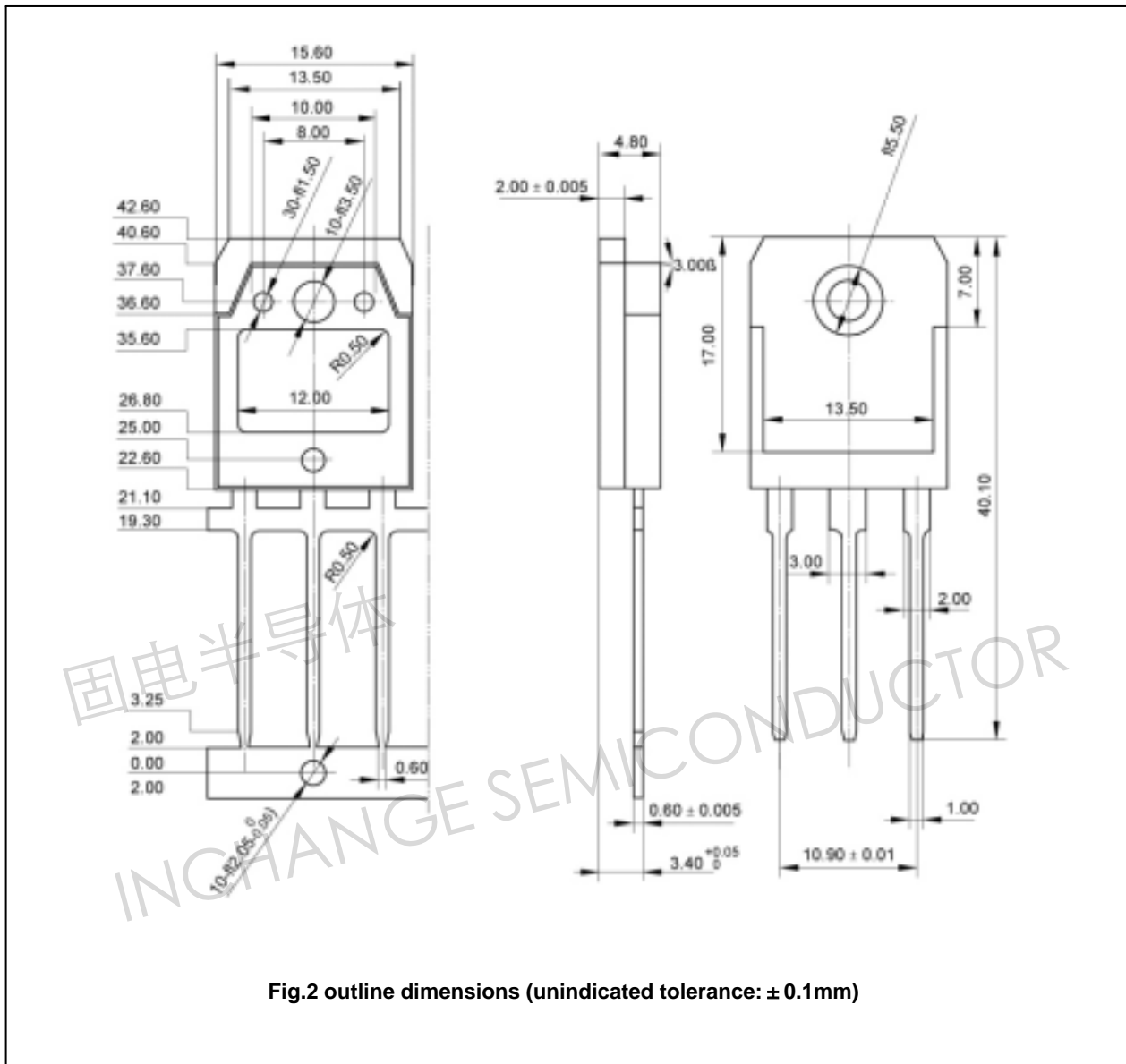

Fig.2 outline dimensions (unindicated tolerance: ± 0.1mm)