



TDA7496L

LINEAR INTEGRATED CIRCUIT

2W+2W AMPLIFIER WITH DC VOLUME CONTROL

DESCRIPTION

The UTC TDA7496L is a stereo 2W+2W class AB power amplifier, specially designed for high quality sound, TV and Monitor applications. Features of the UTC TDA7496L include linear volume control, Stand-by and mute functions.

FEATURES

- *2W+2W output power: $R_L=8 \Omega$ @THD=10%, $V_{CC}=14V$
- *ST-BY and mute functions
- *Low turn-on turn-off pop noise
- *Linear volume control DC coupled with power op. amp.
- *No boucherot cell
- *No ST-BY RC input network
- *Single supply ranging up to 15V
- *Short circuit protection
- *Thermal overload protection
- *Internally fixed gain
- *Soft clipping
- *Variable output after volume control circuit

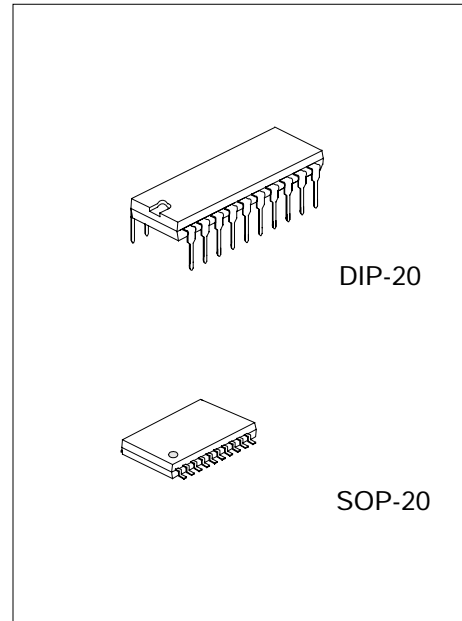

*Pb-free plating product number:TDA7496LK

ORDERING INFORMATION

Order Number		Package	Packing
Normal	Lead Free		
TDA7496L-D20-T	TDA7496LK-D20-T	DIP-20	Tube
TDA7496L-S20-R	TDA7496LK-S20-R	SOP-20	Tape Reel
TDA7496L-S20-T	TDA7496LK-S20-T	SOP-20	Tube

<p>TDA7496LK-D20-T</p> <p>(1) Packing Type (2) Package Type (3) Lead Plating</p>	<p>(1) T: Tube, R: Tape Reel (2) D20: DIP-20, S20: SOP-20 (3) K: Lead Free Plating, Blank: Pb/Sn</p>
--	--

■ PIN CONFIGURATION

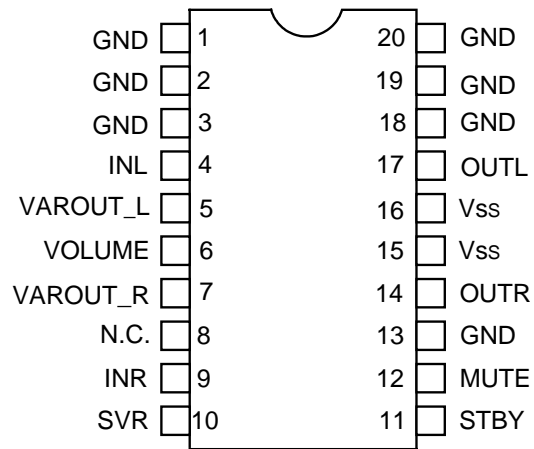

■ BLOCK DIAGRAM

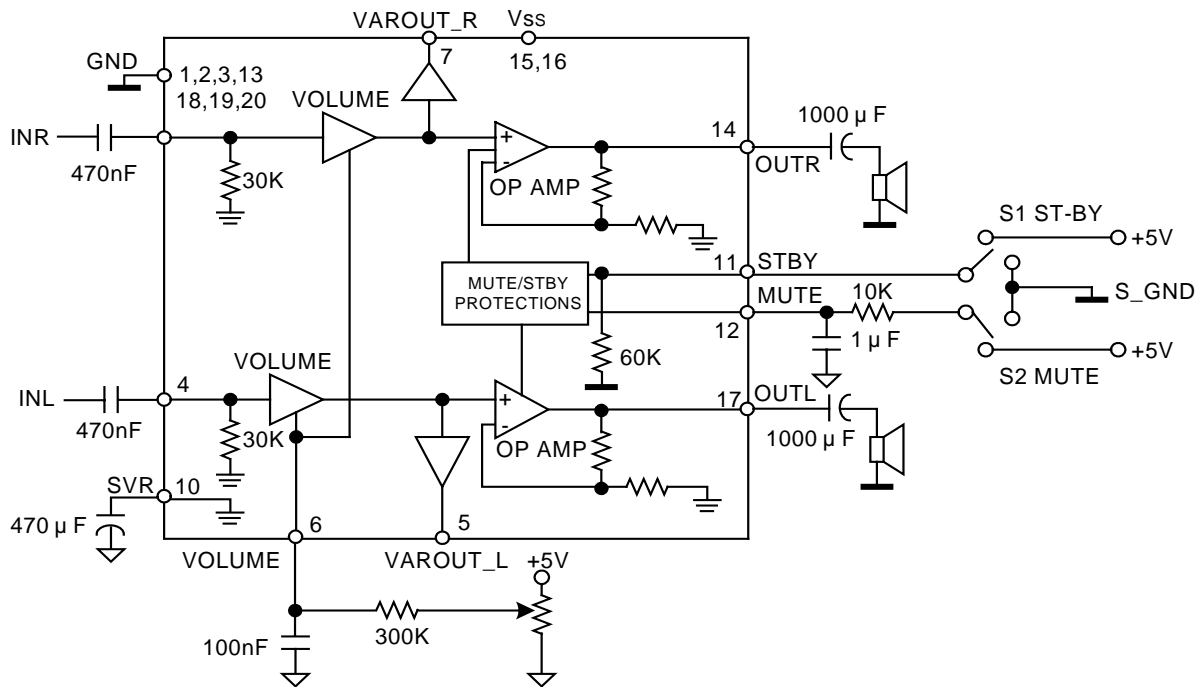

■ ABSOLUTE MAXIMUM RATINGS (Ta=25 , unless otherwise specified.)

PARAMETER	SYMBOL	RATINGS	UNIT
DC Supply Voltage	V _{SS}	26	V
Maximum Input Voltage	V _{IN}	8	V
Volume CTRL DC Voltage	V ₆	6	V
Power Dissipation (Tc =60)	P _D	6	W
Junction Temperature	T _J	+150	°C
Ambient Operating Temperature	T _{OPR}	0 ~ +70	°C
Storage Temperature	T _{STG}	-40 ~ +150	°C

Note: Absolute maximum ratings are those values beyond which the device could be permanently damaged. Absolute maximum ratings are stress ratings only and functional device operation is not implied.

■ ELECTRICAL CHARACTERISTICS (Ta=25 , V_{SS}=14V, unless otherwise specified.)

PARAMETER	SYMBOL	TEST CONDITION	MIN	TYP	MAX	UNIT
Supply Voltage Range	V _{SS}		10		18	V
Quiescent Current	I _Q			25	50	mA
Output DC Offset Referred to SVR Potential	DCV _{os}	No Input Signal		200		mV
Quiescent Output Voltage	V _{OUT}			7		V
Output Power	P _{OUT}	R _L =8	1.6	2		W
				THD=10%	1.3	
Total Harmonic Distortion	THD	G _V =30dB, P _{OUT} =1W, f=1KHz			0.4	%
					THD=1%	
Output Peak Current	I _{O(PEAK)}	(internally limited)	0.7	0.9		A
Input Signal	V _{IN}				2.8	V
Closed Loop Gain	G _V	Vol Ctrl>4.5V	28.5	30	31.5	dB
Monitor Out Gain	G _{V(line)}	Vol Ctrl>4.5V, Z _{LOAD} >30k	-1.5	0	1.5	dB
Attenuation at Minimum Volume	A _{min Vol}	Vol Ctrl<0.5V	80			dB
Bandwidth	BW			0.6		MHz
Total Output Noise	Volume	f=20Hz to 22KHz		500	800	μV
	Attenuation	f=20Hz to 22KHz		100	250	μV
	Mute	f=20Hz to 22KHz		60	150	μV
Slew Rate	SR		5	8		V/μs
Input Resistance	R _{IN}		22.5	30		k
Variable Output Resistance	R _{VAR(OUT)}			30	100	
Variable Output Load	R _{LOAD(OUT)}		2			k
Supply Voltage Rejection f=1kHz	Volume	CSVR=470 μF, VRIP=1V	35	39		dB
	Attenuation		55	65		dB
Thermal Muting	TM			150		°C
Thermal Shut-down	T _s			160		°C

MUTE STAND-BY&INPUT SELECTION FUNCTIONS

Stand-by ON Threshold	V _{ST(ON)}		3.5			V
Stand-by OFF Threshold	V _{ST(OFF)}				1.5	V
Mute ON Threshold	V _{M(ON)}		3.5			V
Mute OFF Threshold	V _{M(OFF)}				1.5	V
Quiescent Current@ Stand-by	I _{QST-BY}			0.6	1	mA
Mute Attenuation	AMUTE		50	65		dB
Stand-by bias current	I _{BIAS(ST-BY)}	Stand by on V _{ST-BY} =5V V _{MUTE} =5V		80		μA
		Play or Mute	-20	-5		μA
Mute bias current	I _{BIAS(MUTE)}	Mute		1	5	μA
		Play		0.2	2	μA

■ APPLICATION SUGGESTIONS

The recommended values of the external components are those shown on the application circuit of figure 1. Different values can be used, the following table can help the designer.

Component	Suggestion Value	Purpose	Larger Than Suggestion	Smaller Than Suggestion
R1	300K	Volume control circuit	Larger volume regulation time	Smaller volume regulation time
R2	10K	Mute time constant	Larger mute on/off time	Smaller mute on/off time
P1	50K	Volume control circuit		
C1	1000 μ F	Supply voltage bypass		Danger of oscillation
C2	470nF	Input DC decoupling	Lower low frequency cutoff	Higher low frequency cutoff
C3	470nF	Input DC decoupling	Lower low frequency cutoff	Higher low frequency cutoff
C4	470 μ F	Ripple rejection	Better SVR	Worse SVR
C5	100nF	Volume control time Constant	Larger volume regulation time	Smaller volume regulation time
C6	1000 μ F	Output DC decoupling	Lower low frequency cutoff	Higher low frequency cutoff
C7	1 μ F	Mute time constant	Larger mute on/off time	Smaller mute on/off time
C8	1000 μ F	Output DC decoupling	Lower low frequency cutoff	Higher low frequency cutoff
C9	100nF	Supply voltage bypass		Danger of oscillation

■ TYPICAL APPLICATION CIRCUIT

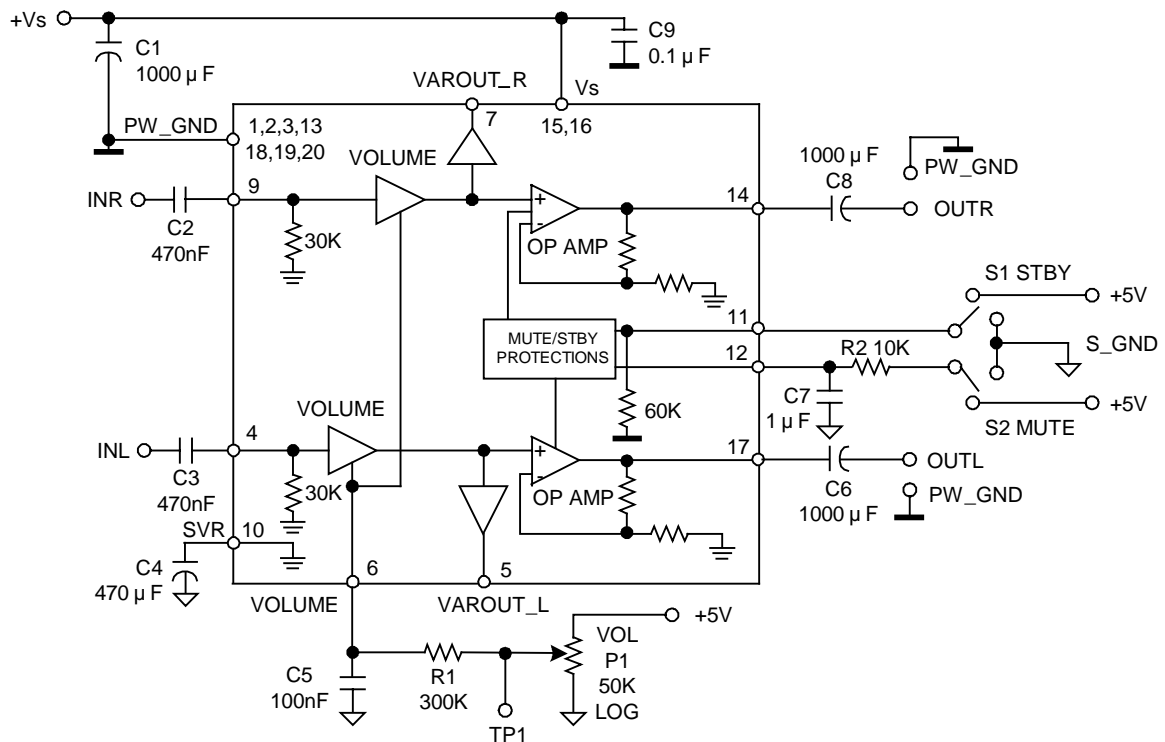

FIGURE 1. APPLICATION CIRCUIT

■ MUTE STAND-BY TRUTH TABLE

MUTE	ST-BY	OPERATING CONDITION
H	H	STANDBY
L	H	STANDBY
H	L	MUTE
L	L	PLAY

■ TURN ON/OFF SEQUENCES (FOR OPTIMIZING THE POP PERFORMANCES)

(A) USING MUTE AND STAND-BY FUNCTIONS

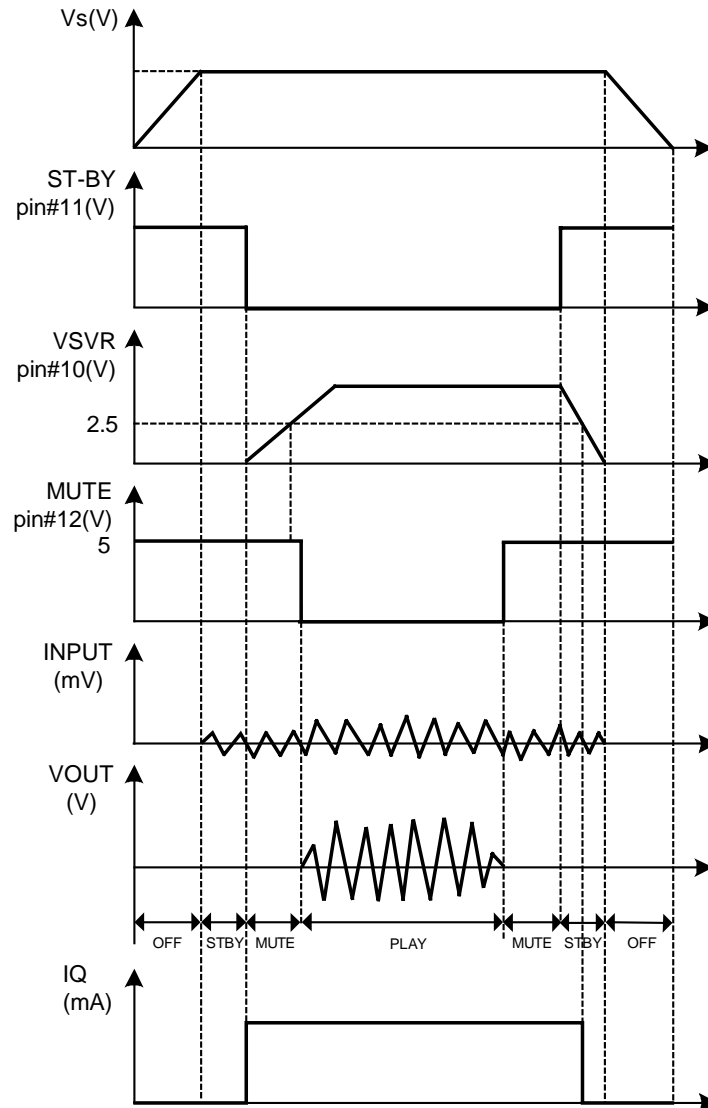

(B) USING ONLY THE MUTE FUNCTION

To simplify the application, the stand-by pin can be connected directly to Ground. During the ON/OFF transitions it is recommended to respect the following conditions.

At the turn-on, the transition mute - play must be made when the SVR pin is higher than 2.5V.

At the turn-off, the TDA7496L must be brought to mute from the play condition when the SVR pin is higher than 2.5V.

FUNCTIONAL DESCRIPTION

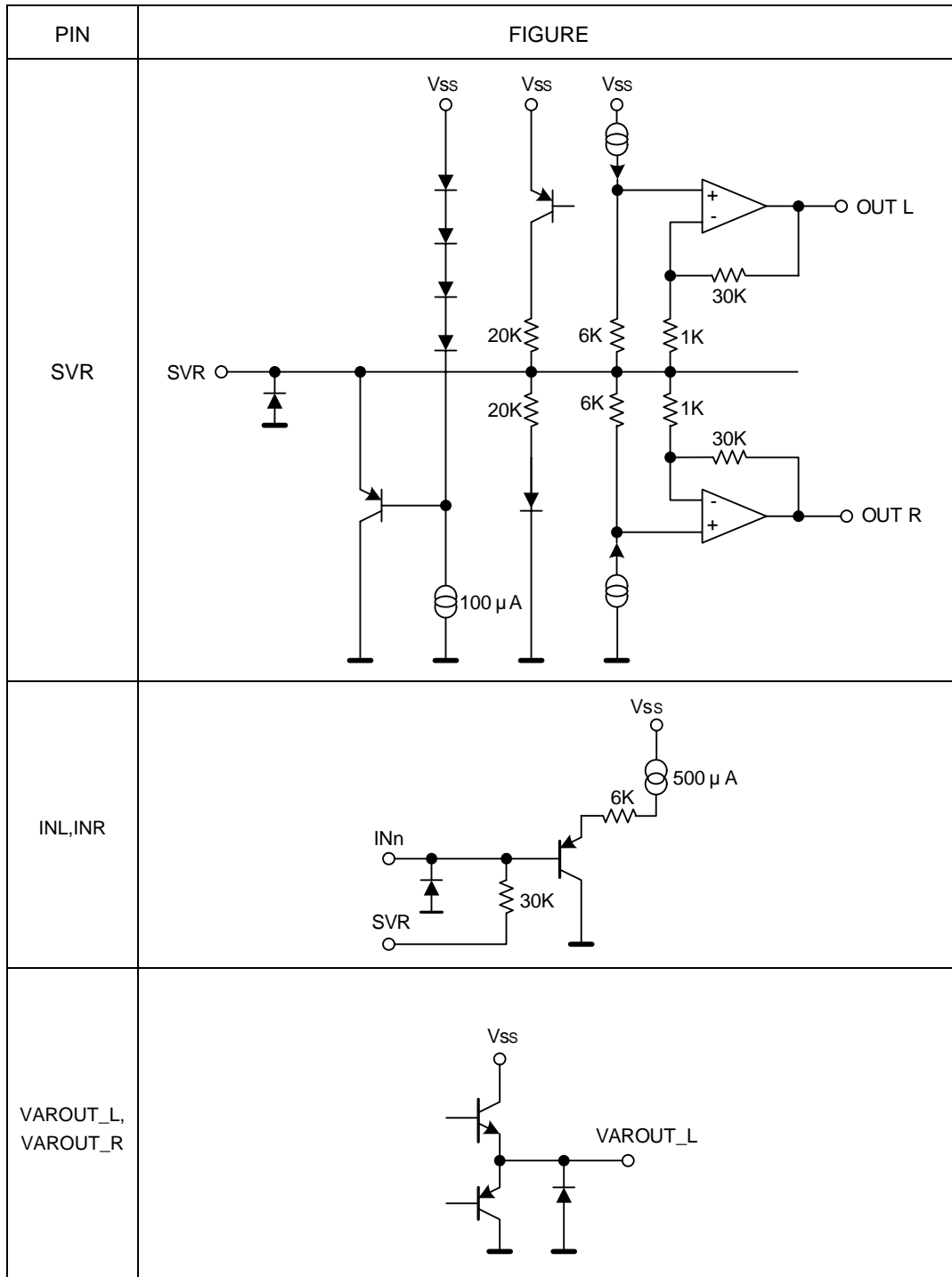

■ FUNCTIONAL DESCRIPTION(Cont.)

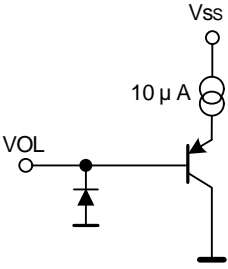
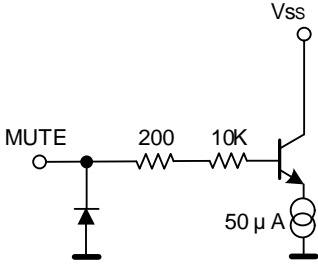
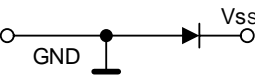
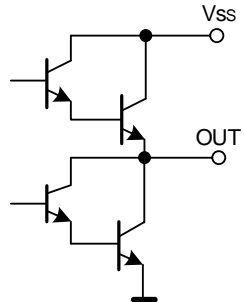
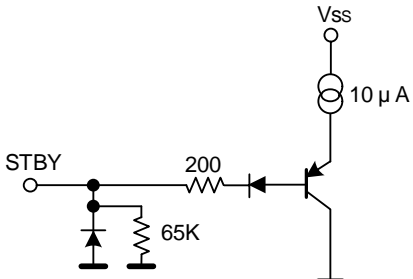
PIN	FIGURE
VOLUME	
MUTE	
PW_GND, S_GND	
VAROUT-L, VAROUT-R	
STBY	

TYPICAL CHARACTERISTICS

Quiescent current vs. Supply Voltage

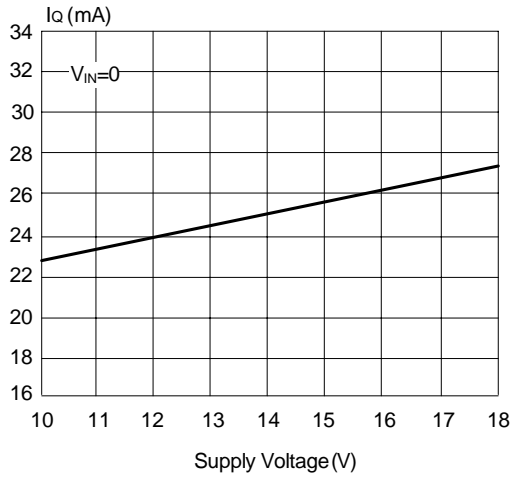

Output DC Voltage vs. Supply Voltage

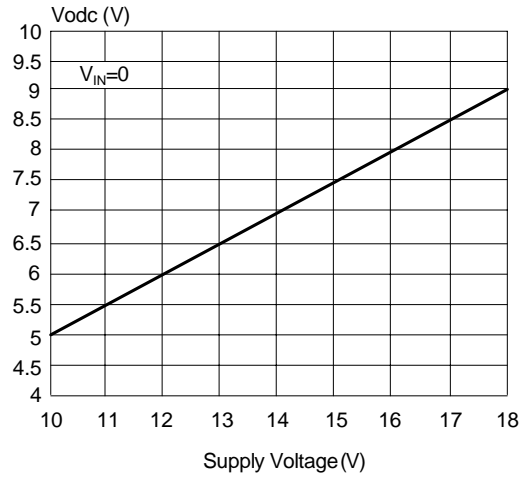

Output DC Offset vs. Supply Voltage

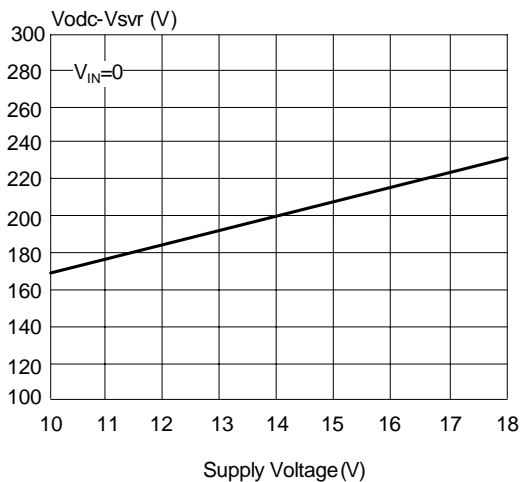

Output Power vs. Supply Voltage

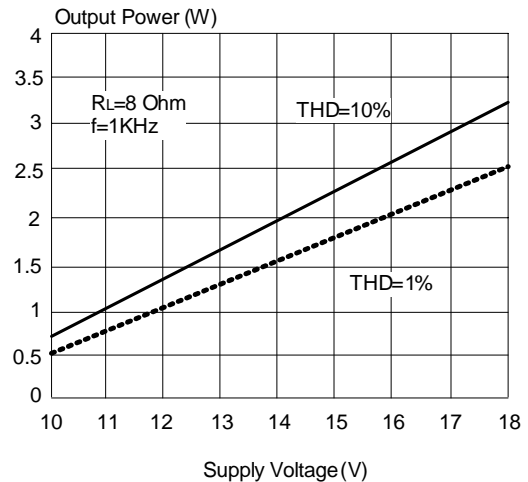

Distortion vs. Output Power

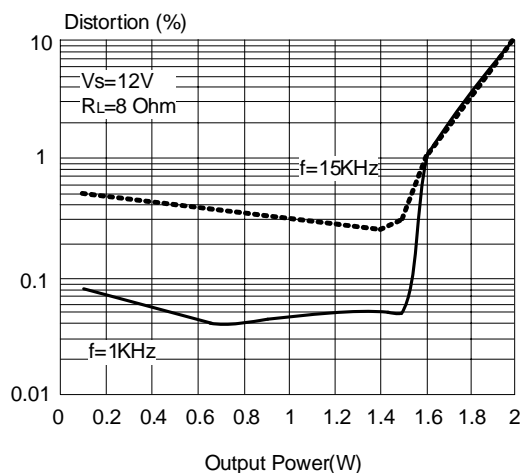

Closed Loop gain vs. Frequency

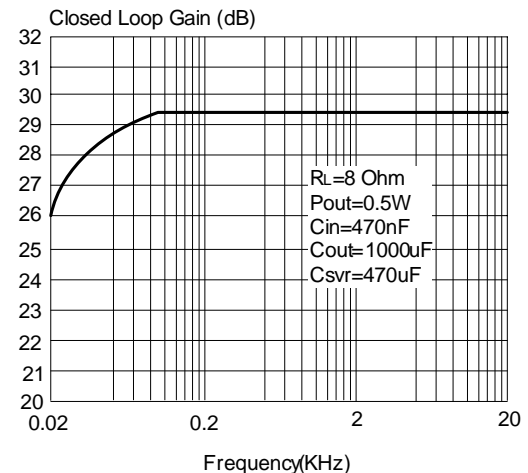

■ TYPICAL CHARACTERISTICS (Cont.)

St-By Attenuatio vs.Vpin

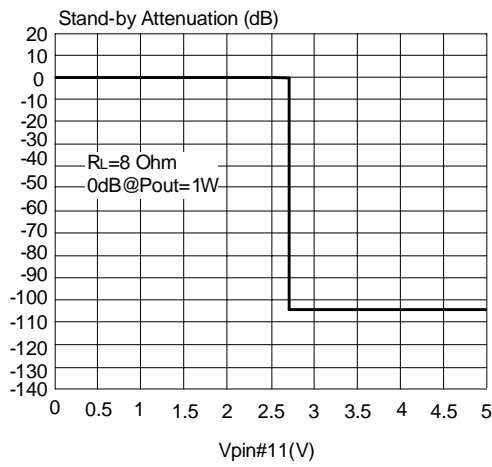

Mute Attenuation vs.Vpin 12

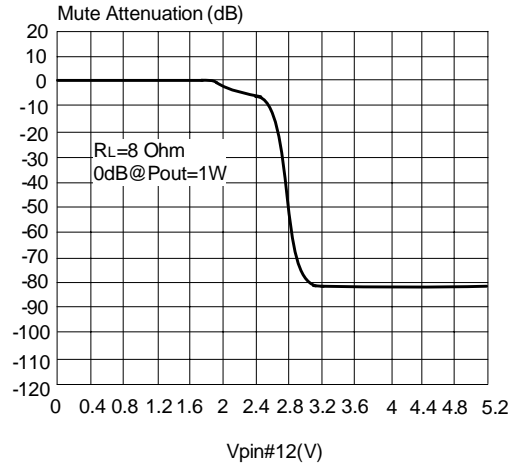

UTC assumes no responsibility for equipment failures that result from using products at values that exceed, even momentarily, rated values (such as maximum ratings, operating condition ranges, or other parameters) listed in products specifications of any and all UTC products described or contained herein. UTC products are not designed for use in life support appliances, devices or systems where malfunction of these products can be reasonably expected to result in personal injury. Reproduction in whole or in part is prohibited without the prior written consent of the copyright owner. The information presented in this document does not form part of any quotation or contract, is believed to be accurate and reliable and may be changed without notice.