

Silicon PNP Power Transistors

2SA1359

DESCRIPTION

- With TO-126 package
- Complement to type 2SC3422
- Good linearity of  $h_{FE}$

APPLICATIONS

- Audio frequency amplifier
- Low speed switching
- Suitable for output stage of 5W car radio and car stereo

PINNING

PIN	DESCRIPTION
1	Emitter
2	Collector;connected to mounting base
3	Base

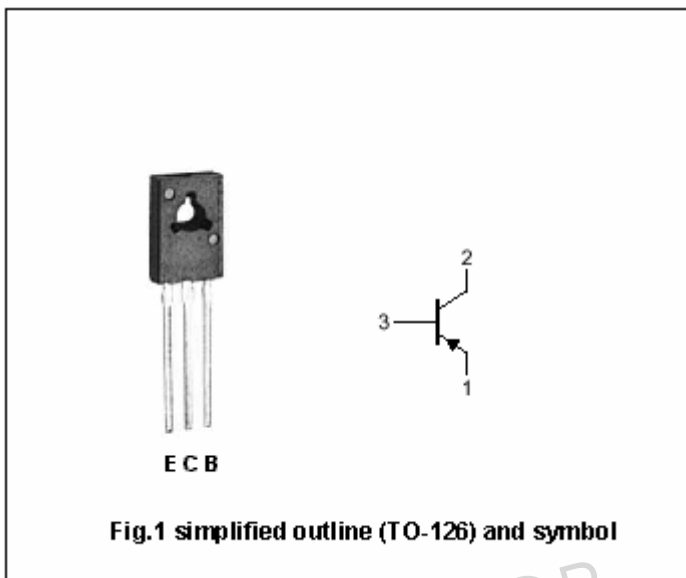

Absolute maximum ratings( $T_a=25^\circ\text{C}$ )

SYMBOL	PARAMETER	CONDITIONS	VALUE	UNIT
$V_{CBO}$	Collector-base voltage	Open emitter	-40	V
$V_{CEO}$	Collector-emitter voltage	Open base	-40	V
$V_{EBO}$	Emitter-base voltage	Open collector	-5	V
$I_C$	Collector current		-3	A
$I_B$	Base current		-1	A
$P_D$	Total power dissipation	$T_a=25$	1.5	W
		$T_C=25$	10	
$T_j$	Junction temperature		150	
$T_{stg}$	Storage temperature		-55 ~ +150	

## Silicon PNP Power Transistors

## 2SA1359

## CHARACTERISTICS

T<sub>j</sub>=25 unless otherwise specified

SYMBOL	PARAMETER	CONDITIONS	MIN	TYP.	MAX	UNIT
V <sub>(BR)CEO</sub>	Collector-emitter breakdown voltage	I <sub>C</sub> =-10mA ; I <sub>B</sub> =0	-40			V
V <sub>CEsat</sub>	Collector-emitter saturation voltage	I <sub>C</sub> =-2A; I <sub>B</sub> =-0.2A			-0.8	V
V <sub>BE</sub>	Base-emitter on voltage	I <sub>C</sub> =-0.5A ; V <sub>CE</sub> =-2V			-1.0	V
I <sub>CBO</sub>	Collector cut-off current	V <sub>CB</sub> =-40V; I <sub>E</sub> =0			-0.1	μA
I <sub>EBO</sub>	Emitter cut-off current	V <sub>EB</sub> =-5V; I <sub>C</sub> =0			-0.1	μA
h <sub>FE-1</sub>	DC current gain	I <sub>C</sub> =-0.5A ; V <sub>CE</sub> =-2V	80		240	
h <sub>FE-2</sub>	DC current gain	I <sub>C</sub> =-2.5A ; V <sub>CE</sub> =-2V	25			
C <sub>ob</sub>	Output capacitance	I <sub>E</sub> =0 ; V <sub>CB</sub> =-10V f=1MHz		35		pF
f <sub>T</sub>	Transition frequency	I <sub>C</sub> =-0.5A ; V <sub>CE</sub> =-2V		100		MHz

◆ h<sub>FE-1</sub> Classifications

O	Y
80-160	120-240

PACKAGE OUTLINE

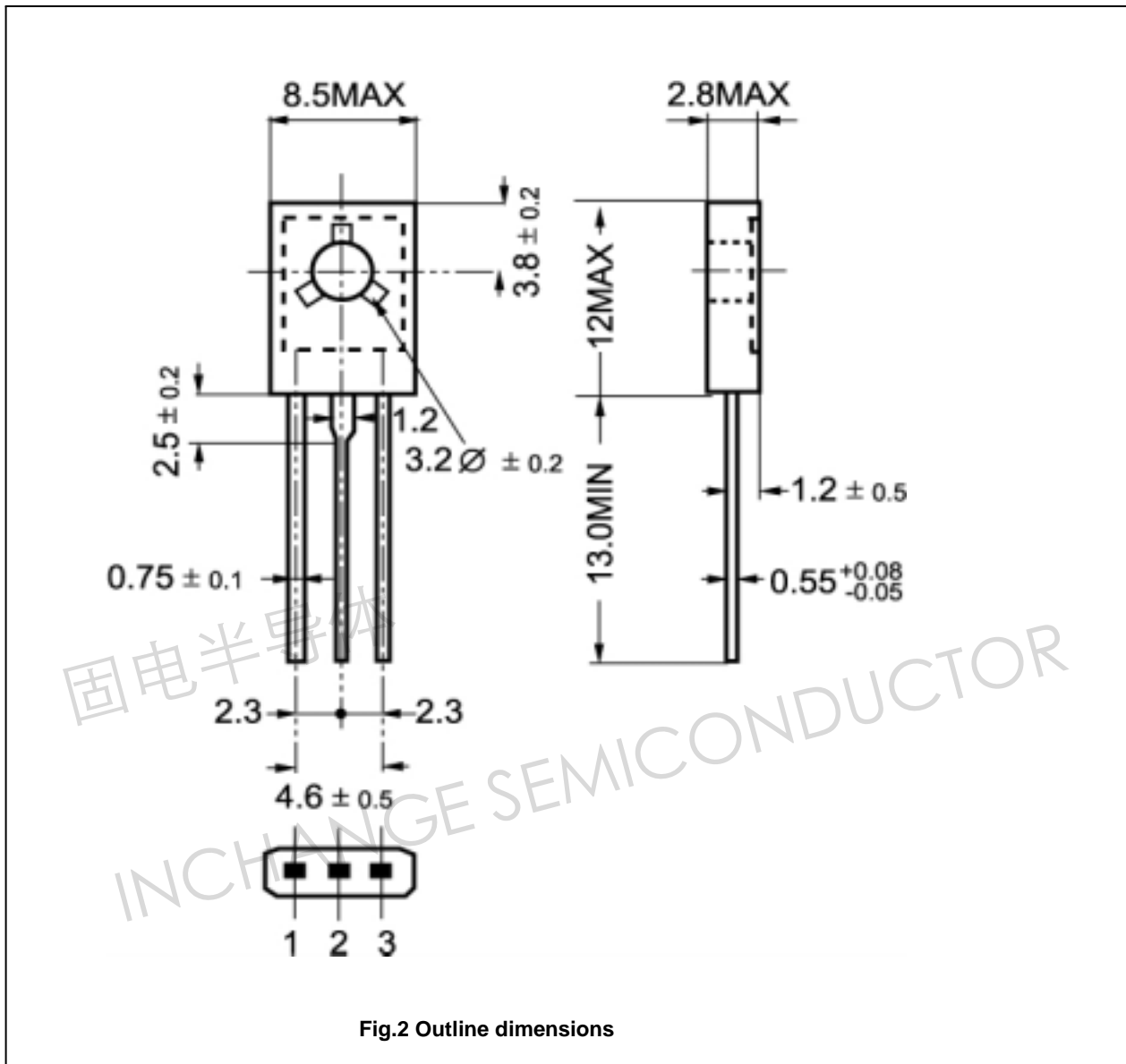

Silicon PNP Power Transistors

2SA1359

