

No.1268

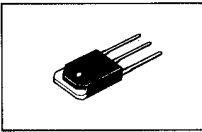

2SD1401

NPN Triple Diffused Planar Type Silicon Transistor
FOR CTV HORIZONTAL DEFLECTION OUTPUT

Features:

- High breakdown voltage and high reliability
- High switching speed
- Capable of being mounted easily due to one-point fixing type plastic mold package

Absolute Maximum Ratings at Ta=25°C

			unit
Collector to Base Voltage	V _{CB0}	1500	V
Collector to Emitter Voltage	V _{CE0}	800	V
Emitter to Base Voltage	V _{EB0}	7	V
Collector Current	I _C	3.5	A
Peak Collector Current	i _{cp}	10	A
Collector Dissipation	P _C	80	W
Junction Temperature	T _j	150	°C
Storage Temperature	T _{stg}	-55 to +150	°C

Electrical Characteristics at Ta=25°C

			min	typ	max	unit
Collector Cutoff Current	I _{CB0}	V _{CB} =800V, I _E =0			10	uA
Emitter Cutoff Current	I _{EB0}	V _{EB} =5V, I _C =0			1	mA
DC Current Gain	h _{FE}	V _{CE} =5V, I _C =0.5A	8			
Gain Bandwidth Product	f _T	V _{CE} =10V, I _C =0.5A		3		MHz
C-E Saturation Voltage	V _{CE(sat)}	I _C =2.5A, I _B =0.8A			8	V
B-E Saturation Voltage	V _{BE(sat)}	I _C =2.5A, I _B =0.8A			1.5	V
C-B Breakdown Voltage	V(BR) _{CBO}	I _C =5mA, I _E =0	1500			V
C-E Breakdown Voltage	V(BR) _{CEO}	I _C =100mA, R _{BE} =∞	800			V
E-B Breakdown Voltage	V(BR) _{EBO}	I _E =200mA, I _C =0	7			V
Fall Time	t _f	I _C =3A, I _{B1} =0.8A, I _{B2} =-1.6A			0.7	us

Switching Time Test Circuit

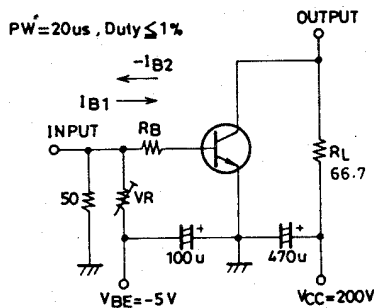

Case Outline 2022 (unit:mm)

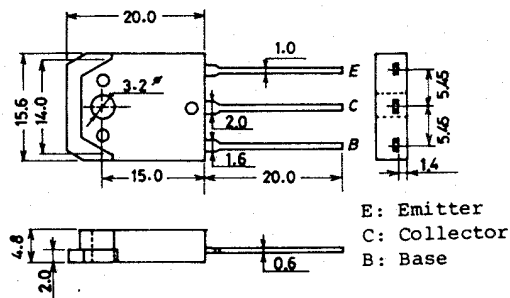

These specifications are subject to change without notice.

TOKYO SANYO ELECTRIC CO., LTD. SEMICONDUCTOR DIVISION
15-13, 6-CHOME, SOTOKANDA, CHIYODA-KU, TOKYO 101 JAPAN