

Silicon NPN Power Transistors

2SD1729

DESCRIPTION

- With TO-3PN package
- Built-in damper diode
- High voltage ,high speed
- Wide area of safe operation

APPLICATIONS

- For horizontal deflection output applications

PINNING

PIN	DESCRIPTION
1	Base
2	Collector;connected to mounting base
3	Emitter

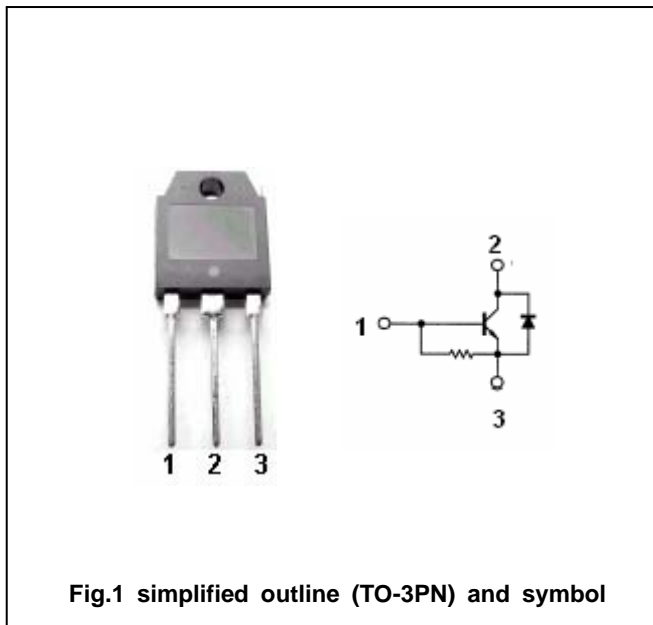

Fig.1 simplified outline (TO-3PN) and symbol

Absolute maximum ratings (Ta=25 )

SYMBOL	PARAMETER	CONDITIONS	VALUE	UNIT
$V_{CBO}$	Collector-base voltage	Open emitter	1500	V
$V_{CEO}$	Collector-emitter voltage	Open base	700	V
$V_{EBO}$	Emitter-base voltage	Open collector	7	V
$I_C$	Collector current (DC)		3.5	A
$I_{CM}$	Collector current (Pulse)		10	A
$I_B$	Base current		1.5	A
$P_C$	Collector power dissipation	$T_C=25$	60	W
$T_j$	Junction temperature		150	
$T_{stg}$	Storage temperature		-55~150	

## Silicon NPN Power Transistors

## 2SD1729

## CHARACTERISTICS

T<sub>j</sub>=25 unless otherwise specified

SYMBOL	PARAMETER	CONDITIONS	MIN	TYP.	MAX	UNIT
V <sub>(BR)EBO</sub>	Emitter-base breakdown voltage	I <sub>E</sub> =500mA; I <sub>C</sub> =0	7			V
V <sub>CEsat</sub>	Collector-emitter saturation voltage	I <sub>C</sub> =3A; I <sub>B</sub> =0.8A			8.0	V
V <sub>BEsat</sub>	Base-emitter saturation voltage	I <sub>C</sub> =3A; I <sub>B</sub> =0.8A			1.5	V
I <sub>CBO</sub>	Collector cut-off current	V <sub>CB</sub> =750V; I <sub>E</sub> =0			10	μA
		V <sub>CB</sub> =1500V; I <sub>E</sub> =0			1	mA
h <sub>FE</sub>	DC current gain	I <sub>C</sub> =0.5A; V <sub>CE</sub> =5V	5		25	
f <sub>T</sub>	Transition frequency	I <sub>C</sub> =0.5A; V <sub>CE</sub> =10V		2		MHz
V <sub>F</sub>	Diode forward voltage	I <sub>F</sub> =-3.5A, I <sub>B</sub> =0			2.0	V
Switching times						
t <sub>s</sub>	Storage time	I <sub>C</sub> =3A; I <sub>B1</sub> =0.8A I <sub>B2</sub> =-1.6A V <sub>CC</sub> =200V		1.5		μs
t <sub>f</sub>	Fall time			0.2		μs

Silicon NPN Power Transistors

2SD1729

PACKAGE OUTLINE

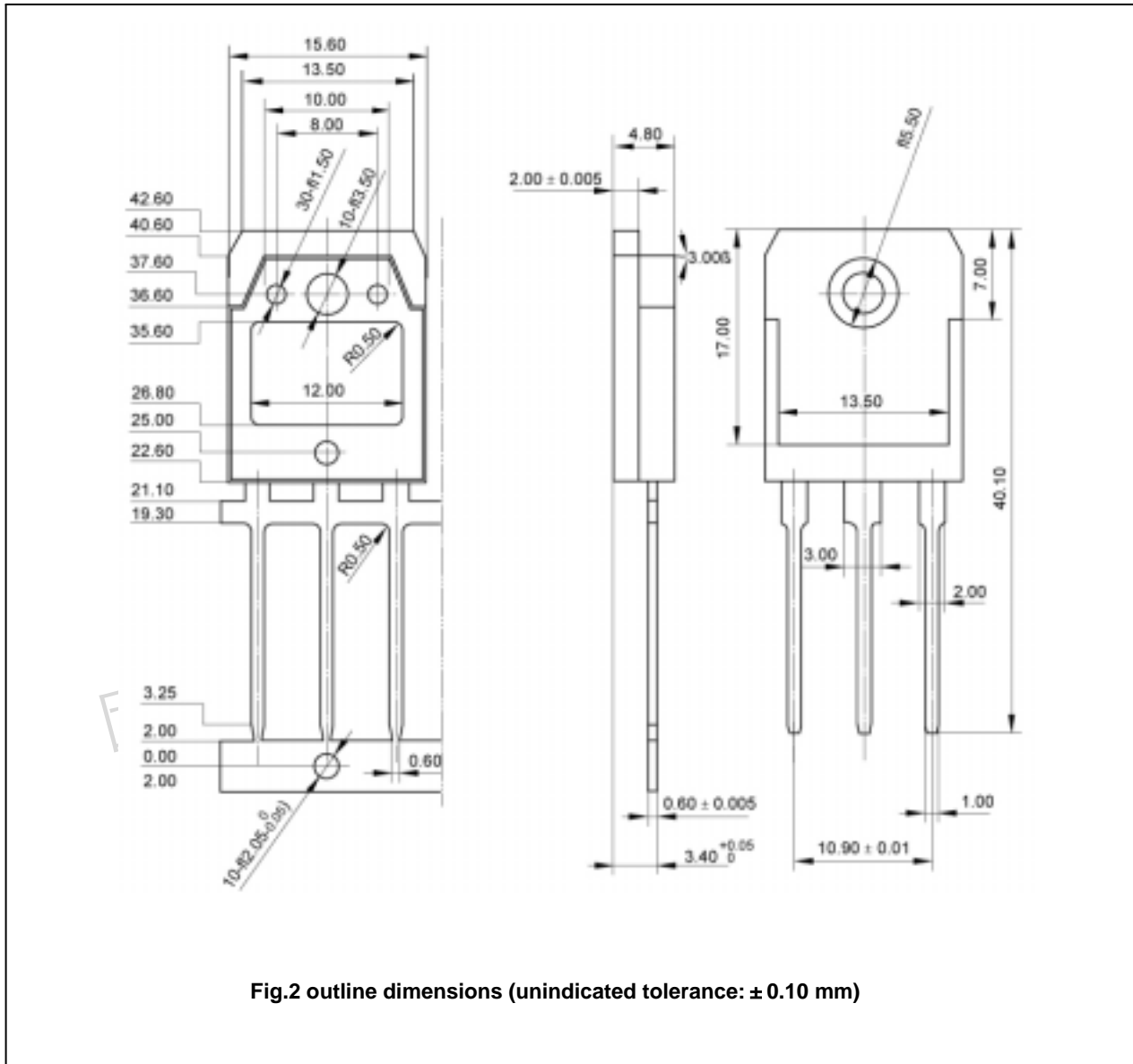

Fig.2 outline dimensions (unindicated tolerance: ± 0.10 mm)