

AN6170, AN6170S

Tone Ringers

Overview

The AN6170 and the AN6170S are integrated circuits designed for telephone set and generates a call tone for telephone set.

Features

- Low current operation
- Adjustable, three-frequency tone
- Since the threshold circuit is incorporated, it is free from resonance.
- Resistance of pin 2 allows the resonance start current to be variable.

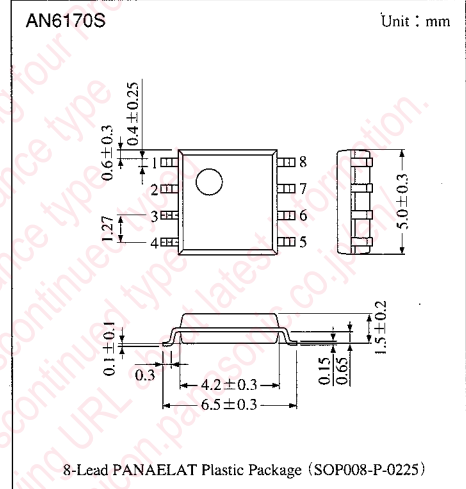
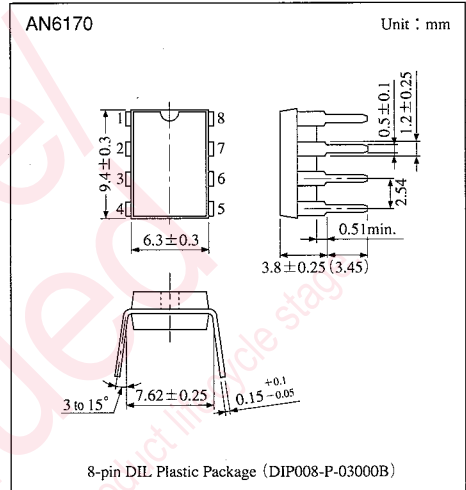

Block Diagram

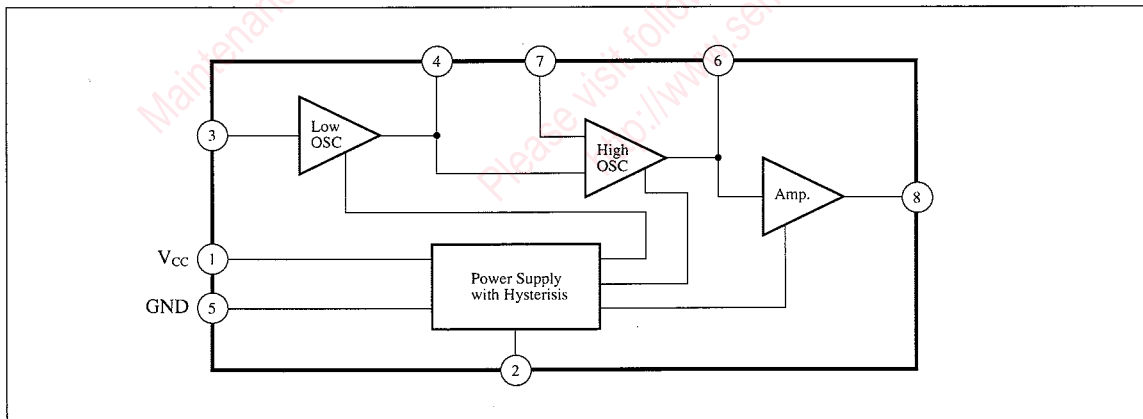

■ Absolute Maximum Ratings ($T_a=25^\circ\text{C}$)

Parameter	Symbol	Rating	Unit
Supply voltage	V_{CC}	30	V
Supply current	I_{CC}	— *1	mA
Power dissipation	AN6170	P_D	mW
	AN6170S		
Operating ambient temperature	T_{opr}	-30 to +75	$^\circ\text{C}$
Storage temperature	AN6170	T_{stg}	$^\circ\text{C}$
	AN6170S		
		-55 to +125	

*1 $P_D > V_{CC} \times I_{CC}$

■ Recommended Operating Range ($T_a=25^\circ\text{C}$)

Parameter	Symbol	Range
Operating supply voltage range	V_{CC}	8 to 30V

■ Electrical Characteristics ($T_a=25^\circ\text{C}$)

Parameter	Symbol	Condition	min	typ	max	Unit
Rumbling starting supply voltage *1	V_{st}	$R_S = 7.5\text{k}\Omega$	14.5	16.5	18.5	V
Rumbling continuous supply voltage *1	V_{con}	$R_S = 7.5\text{k}\Omega$	7.5	9.5	11.5	V
Rumbling starting current consumption *1	I_{st}	$R_S = 7.5\text{k}\Omega$	1.5	2.4	3.5	mA
Rumbling continuous current consumption *1	I_{con}	$R_S = 7.5\text{k}\Omega$	0.4	0.75	1.15	mA
Output frequency (1) *2	f_w		13	14	15	Hz
Output frequency (2) *3	f_1		967	1040	1113	Hz
Output frequency (3) *4	f_2		1204	1295	1386	Hz
Output voltage H level	V_{OH}	$I_S = -10\text{mA}$	20	—	—	V
Output voltage L level	V_{OL}	$I_S = +10\text{mA}$	—	—	2	V

*1 Refer to the characteristic. *2 $f_w = 0.697 / (C_{O1} \cdot R_{O1})$. *3 $f_1 = 0.634 / (C_{O2} \cdot R_{O2})$. *4 $f_2 = 1.24 \cdot f_1$

■ Application Circuit

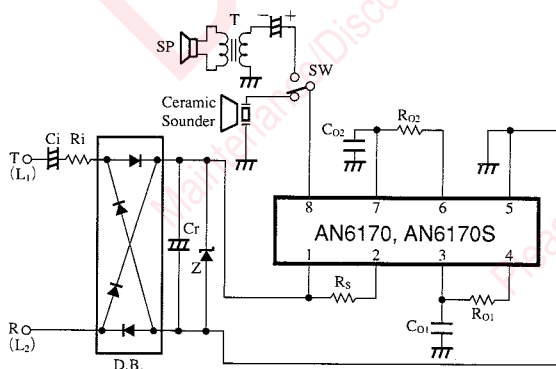

Parts name	Symbol	Recommended parts
Input capacitance	C_1	Matsushita 0.9-250 (0.9 μF), 474K-250
Input resistance	R_1	2.2k Ω
Diode bridge	D.B.	—
Capacitance	C_r	15 $\mu\text{F}/35\text{V}$
Zener diode	Z	Matsushita MA1300L (27V)
Short-circuit resistance	R_S	7.5k Ω
Oscillation resistance	R_{O1}	110k Ω
Oscillation resistance	R_{O2}	130k Ω
Oscillation capacitance	C_{O1}	0.47 μF
Oscillation capacitance	C_{O2}	Poluester 4700pF
Ceramic sounder	—	Matsushita EFB-RR
		Matsushita EFB-RW
Speaker	SP	Matsushita EAS-6P32S (8 Ω)
Transformer	T	8 Ω : 2k Ω

ICs for Telephone

Pin Descriptions

Pin No.	Pin name
1	V _{CC}
2	R _s
3	OSC
4	OSC
5	GND
6	OSC
7	OSC
8	V _O

Characteristics Curve

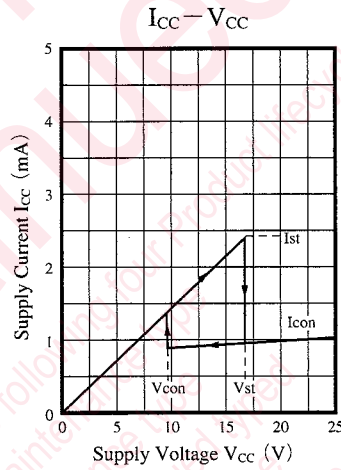
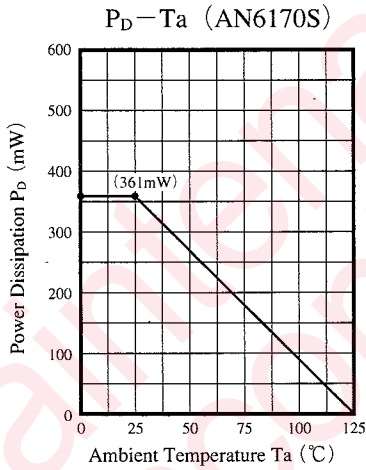

Request for your special attention and precautions in using the technical information and semiconductors described in this book

- (1) If any of the products or technical information described in this book is to be exported or provided to non-residents, the laws and regulations of the exporting country, especially, those with regard to security export control, must be observed.
- (2) The technical information described in this book is intended only to show the main characteristics and application circuit examples of the products. No license is granted in and to any intellectual property right or other right owned by Panasonic Corporation or any other company. Therefore, no responsibility is assumed by our company as to the infringement upon any such right owned by any other company which may arise as a result of the use of technical information described in this book.
- (3) The products described in this book are intended to be used for standard applications or general electronic equipment (such as office equipment, communications equipment, measuring instruments and household appliances).
Consult our sales staff in advance for information on the following applications:
 - Special applications (such as for airplanes, aerospace, automobiles, traffic control equipment, combustion equipment, life support systems and safety devices) in which exceptional quality and reliability are required, or if the failure or malfunction of the products may directly jeopardize life or harm the human body.
 - Any applications other than the standard applications intended.
- (4) The products and product specifications described in this book are subject to change without notice for modification and/or improvement. At the final stage of your design, purchasing, or use of the products, therefore, ask for the most up-to-date Product Standards in advance to make sure that the latest specifications satisfy your requirements.
- (5) When designing your equipment, comply with the range of absolute maximum rating and the guaranteed operating conditions (operating power supply voltage and operating environment etc.). Especially, please be careful not to exceed the range of absolute maximum rating on the transient state, such as power-on, power-off and mode-switching. Otherwise, we will not be liable for any defect which may arise later in your equipment.
 - Even when the products are used within the guaranteed values, take into the consideration of incidence of break down and failure mode, possible to occur to semiconductor products. Measures on the systems such as redundant design, arresting the spread of fire or preventing glitch are recommended in order to prevent physical injury, fire, social damages, for example, by using the products.
- (6) Comply with the instructions for use in order to prevent breakdown and characteristics change due to external factors (ESD, EOS, thermal stress and mechanical stress) at the time of handling, mounting or at customer's process. When using products for which damp-proof packing is required, satisfy the conditions, such as shelf life and the elapsed time since first opening the packages.
- (7) This book may be not reprinted or reproduced whether wholly or partially, without the prior written permission of our company.