

CONTRAST, SATURATION AND BRIGHTNESS CONTROL CIRCUIT FOR COLOUR DIFFERENCE AND LUMINANCE SIGNALS

The TCA660B is an integrated circuit performing the control functions of contrast, saturation and brightness in colour television receivers.

Contrast is controlled by three tracking electronic potentiometers; one for the luminance signal and the other two for the (R-Y) and (B-Y) colour difference signals.

In addition two tracking electronic potentiometers provide the saturation control of the colour difference signals.

Brightness is controlled by varying the black level of the luminance signal at the output. An inverting amplifier is also included for matrixing the (G-Y) signal from the (R-Y) and (B-Y) colour difference signals.

QUICK REFERENCE DATA

Supply voltage	V_{13-4}	nom.	12	V
Supply current	I_{13}	nom.	35	mA

Luminance input current (black-to-white positive video signal)	I_{16}	typ.	0,7	mA
Luminance output voltage (black-to-white positive video signal; peak-to-peak value)	$V_{1-4(p-p)}$	typ.	3	V ¹⁾
Black level (nominal value)	V_{1-4}	typ.	4,2	V
Brightness control (around nominal black level)	V_{1-4}		+1 to -2	V
Gain of the (R-Y) and (B-Y) amplifier		typ.	5	dB ^{1) 2)}
Gain of the (G-Y) amplifier		typ.	1	
Contrast control range			+3 to -20	dB ³⁾
Saturation control range			+6 to -20	dB ³⁾
¹⁾ At nominal contrast setting (max. contrast -3 dB)				
²⁾ At nominal saturation control setting (max. saturation -6 dB)				
³⁾ Nominal contrast and nominal saturation are specified as 0 dB.				

PACKAGE OUTLINE

16-lead DIL; plastic (SOT-38).

TCA660B

CIRCUIT DIAGRAM

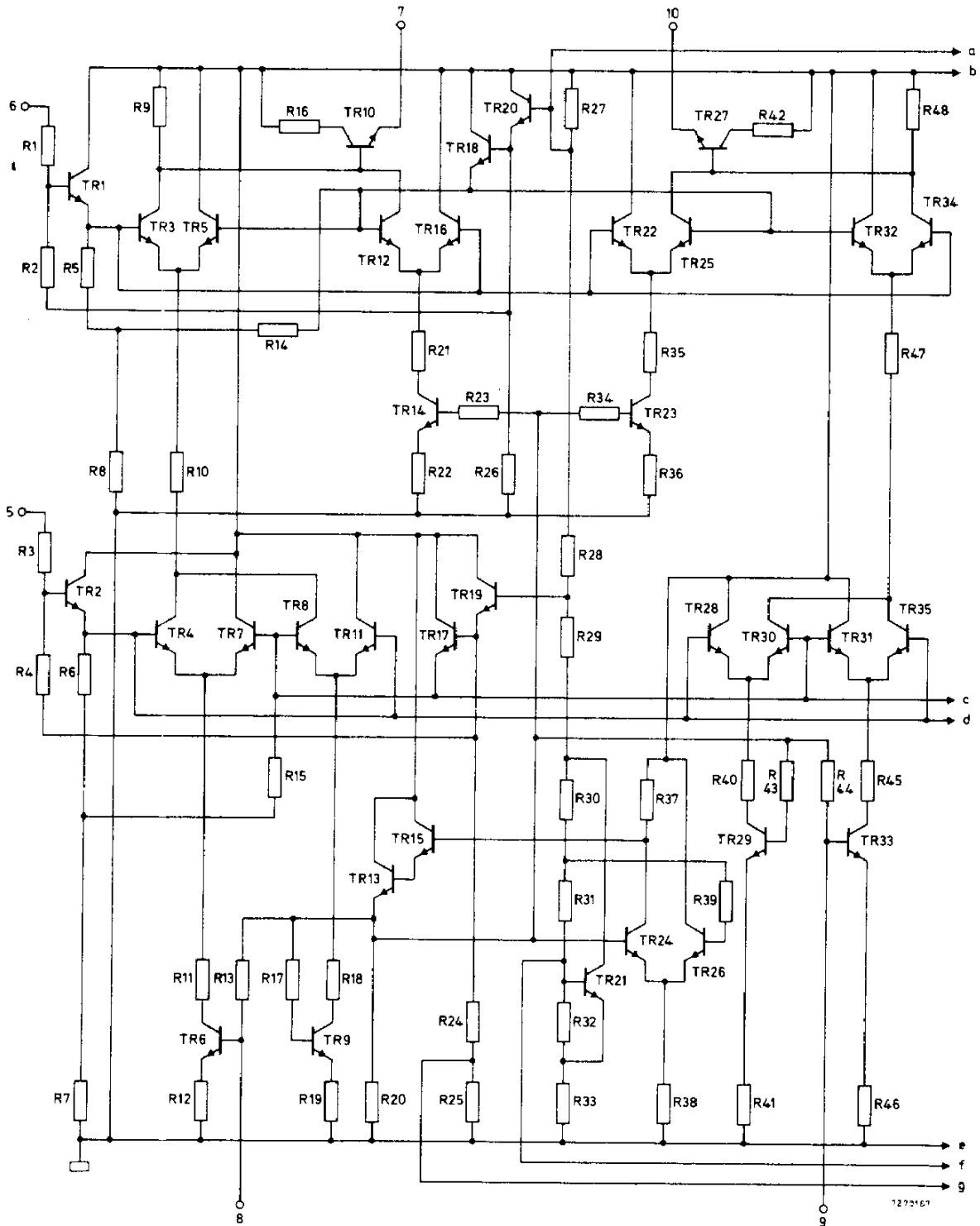

148

CIRCUIT DIAGRAM (continued)

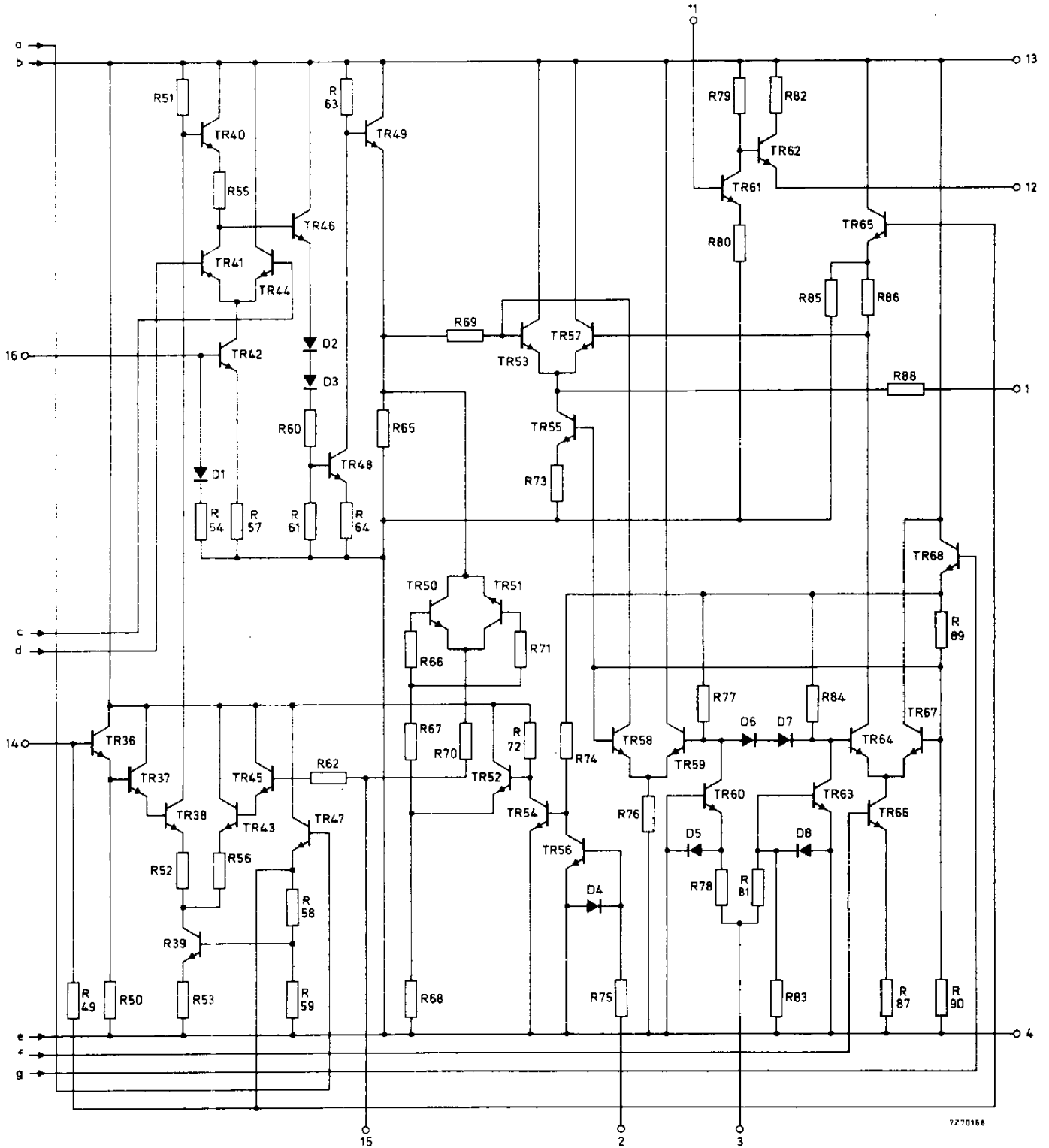

RATINGS Limiting values in accordance with the Absolute Maximum System (IEC 134)

Voltage

Supply voltage V_{13-4} max. 13,2 V

Power dissipation

Total power dissipation P_{tot} max. 600 mW

Temperatures

Storage temperature T_{stg} -25 to +125 °C

Operating ambient temperature T_{amb} -25 to +65 °C ¹⁾

75°C

CHARACTERISTICS measured in the circuit on page 7

Supply voltage V_{13-4} typ. 12 V
10,2 to 13,2 V

Required input signals at $V_{13-4} = 12$ V and $T_{amb} = 25$ °C

Luminance input current

black-to-white positive video signal I_{16} typ. 0,7 mA
0 to 2,5 mA

Input impedance at $I_{16} = 1$ mA $|Z_{16-4}|$ 60 to 90 Ω

Input impedance variation for an input current variation $\Delta I_{16} = \pm 0,5$ mA $|\Delta Z_{16-4}|$ ∓ 25 Ω

Colour difference input voltage

(R-Y): peak-to-peak value $V_{9-4(p-p)}$ < 0,7 V

(B-Y): peak-to-peak value $V_{8-4(p-p)}$ < 0,9 V

Input voltage variation before clipping

of the output voltage occurs ΔV_{8-4} } typ. 0,8 V
 ΔV_{9-4} }

Input impedance $|Z_{8-4}|$ } 3,5 to 6,5 kΩ
 $|Z_{9-4}|$ }

Blanking pulse (peak value) V_{3-4M} -1,5 to -10 V

Black level reinsertion pulse (peak value) V_{3-4M} +2 to +12 V ²⁾

Black level clamp pulse (peak value) V_{2-4M} +1 to +12 V

Luminance output voltage at nominal contrast

black-to-white positive video signal;
peak-to-peak value $V_{1-4(p-p)}$ 2 to 4 V ³⁾

1) When a stabilized power supply of ≤ 12 V is applied, T_{amb} is max. 75 °C.

2) During scan V_{3-4} must be kept lower than 0,7 V (positive and negative) to avoid blanking of the luminance signal.

3) Nominal contrast is specified as maximum contrast -3 dB.

CHARACTERISTICS (continued)

<u>Black level</u> at nominal brightness setting	V_{1-4}	typ.	4,2 V	1)
<u>Black level variation</u> with brightness setting	ΔV_{1-4}		+1 to -2 V	
<u>Contrast control voltage range</u>	V_{5-4}		See graph on page 6	
<u>Black level variation</u> with contrast control	ΔV_{1-4}	<	40 mV	2)
<u>Black level variation</u> with video contents	ΔV_{1-4}	<	20 mV	3)
<u>Variation between video black level</u> and reinserted black level at $\Delta T_{amb} = 25^\circ C$ and $\Delta V_{13-4} \pm 10\%$	V_{1-4}	<	± 20 mV	
<u>Blanking level</u> with respect to nominal brightness	V_{1-4}		-0,8 to -1,2 V	
<u>Bandwidth</u> (-3 dB) of luminance signal	B	>	6 MHz	
<u>Colour difference output signal</u> for nominal contrast and saturation 4) 5)				
(R-Y): peak-to-peak value	$V_{10-4(p-p)}$	typ.	1,25 V	6)
(B-Y): peak-to-peak value	$V_{7-4(p-p)}$	typ.	1,6 V	6)
<u>D.C. output level</u>	V_{7-4} } V_{10-4} }	typ.	6,1 V	
<u>Output level variation</u> with contrast and saturation control	ΔV_{7-4} } ΔV_{10-4} }	<	500 mV	
<u>Permissible d.c. load impedance</u>	$ Z_{7-4} $ } $ Z_{10-4} $ }	>	4 k Ω	
<u>Saturation control voltage range</u>	V_{6-4}		See graph on page 6	
<u>Saturation control</u> at $V_{6-4} < 0,5$ V		<	-50 dB	
<u>Bandwidth</u> (-3 dB) of colour difference signal B		>	2,5 MHz	

1) Nominal brightness setting $V_{14-4} = 5,7$ V.

2) Only valid if the input current does not exceed 0,5 mA during black.

3) For a.c. coupling only.

4) Nominal contrast is specified as maximum contrast -3 dB.

5) Nominal saturation is specified as maximum saturation -6 dB.

6) This value is obtained at the specified maximum input voltage.

CHARACTERISTICS (continued)

(G-Y) amplifier

input voltage (peak-to-peak value)	$V_{11-4(p-p)}$	<	1 V
output voltage (peak-to-peak value)	$V_{12-2(p-p)}$	<	1 V
voltage gain	G_{11-12}		-1 to +0,5 dB

Tracking during contrast and saturation control

at a contrast decrease of 20 dB

change of the ratio $\frac{(R-Y)}{(B-Y)}$ < ±1 dB

change of the ratio $\frac{Y}{(B-Y)}$ 0 to 4 dB

at a saturation decrease of 20 dB

change of the ratio $\frac{(R-Y)}{(B-Y)}$ < ±1 dB

Cross coupling

luminance signal to colour difference signal < -40 dB

(B-Y) signal to (R-Y) signal < -30 dB

colour difference signal to luminance signal < -40 dB

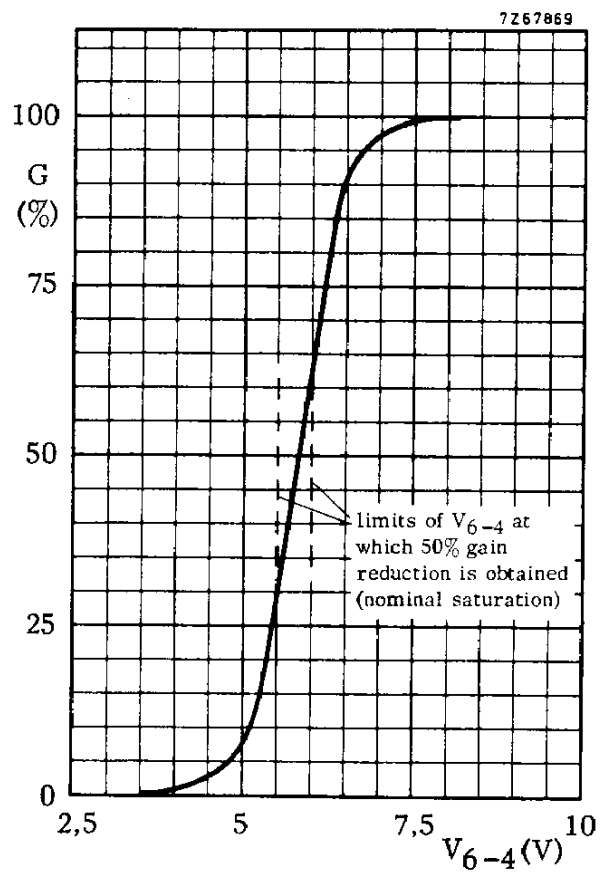
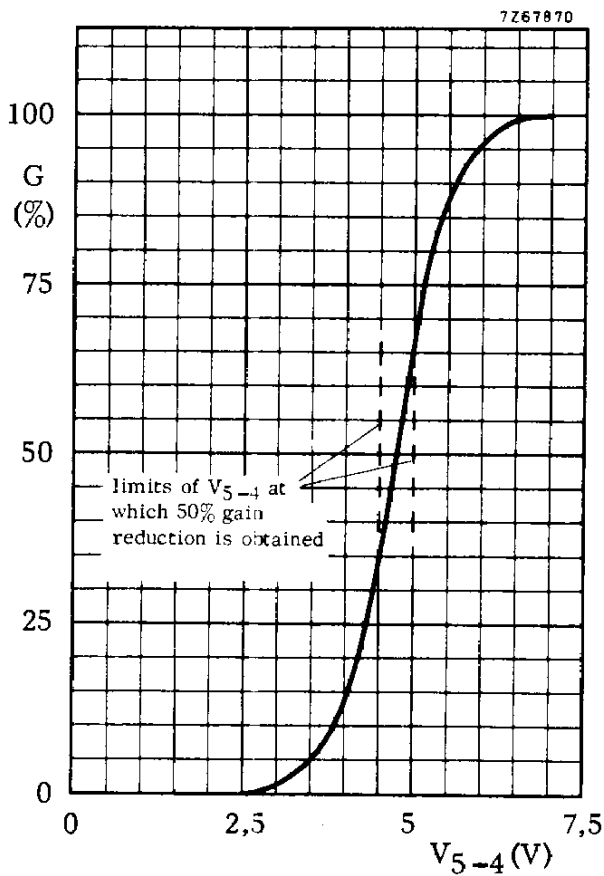

Contrast control of luminance amplifier

Saturation control of chrominance amplifier

APPLICATION INFORMATION

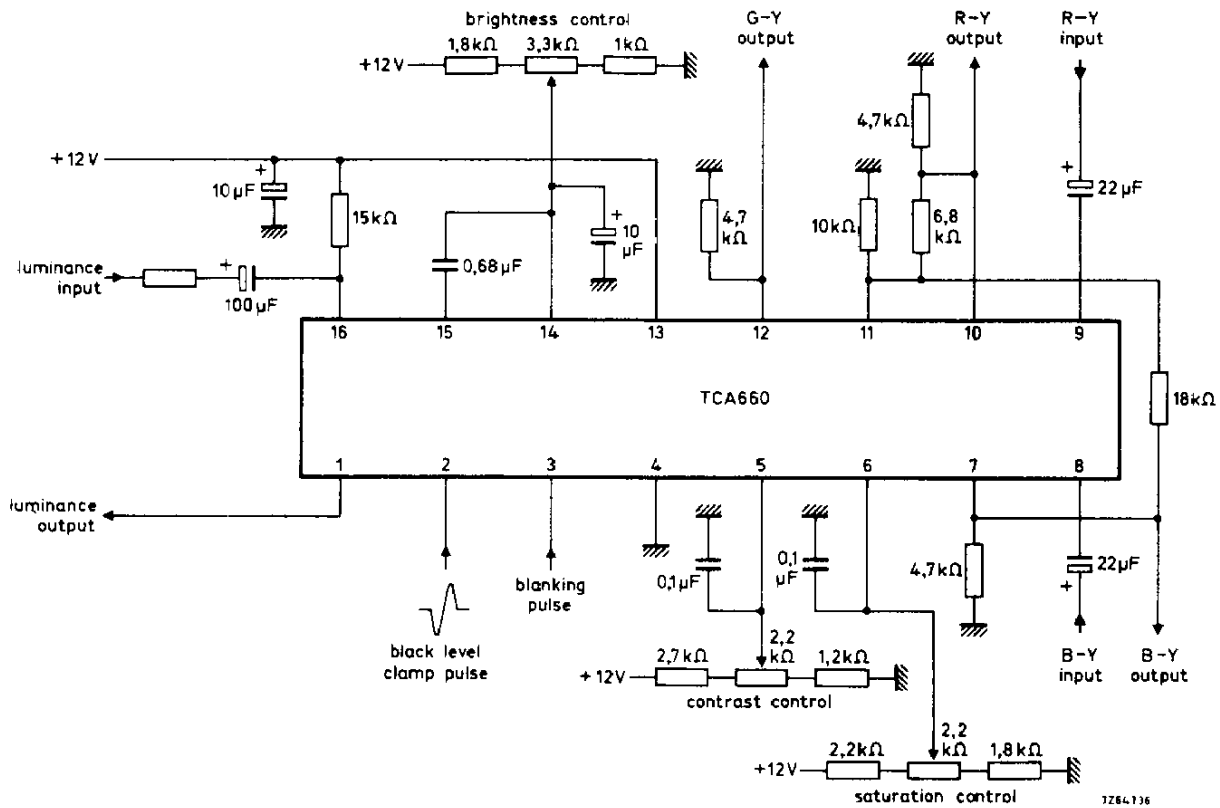

Pinning

- | | |
|----------------------------------|---------------------------------|
| 1. Luminance signal output | 9. (R-Y) signal input |
| 2. Black level clamp pulse input | 10. (R-Y) signal output |
| 3. Blanking pulse input | 11. (G-Y) signal input |
| 4. Earth (negative supply) | 12. (G-Y) signal output |
| 5. Contrast control input | 13. Supply voltage (12 V) |
| 6. Saturation control input | 14. Brightness control input |
| 7. (B-Y) signal output | 15. Black level clamp capacitor |
| 8. (B-Y) signal input | 16. Luminance signal input |

APPLICATION INFORMATION (continued)

The function is quoted against the corresponding pin number

1. Luminance signal output

A positive video signal of 3 V peak-to-peak is available at nominal contrast setting. The black level is clamped internally on the back porch. By means of the brightness control the black level can be varied between 2.2 V and 5.2 V. The blanking level of the output signal will assume a value of 3.0 to 3.4 V.

2. Black level clamp pulse input

A positive pulse with a peak value between +1 V and +12 V will clamp the black level of the video signal to a nominal level of 4.2 V. The pulse may only be present during the back porch and should have a duration of about 3 μ s.

3. Blanking pulse input

Two modes operation can be selected by the choice of the amplitude of the pulse applied:

- blanking
- black level reinsertion

Blanking of the luminance output signal is obtained when the peak value of the pulse ranges from -1.5 to -10 V. An artificial black level of nominally +4.2 V is inserted in the luminance output signal during the blanking period when the peak value of the pulse ranges from +2 to +12 V.

During scan the amplitude at pin 3 should remain between +0.7 V and -0.7 V to avoid blanking.

4. Negative supply (earth)5. Contrast control input

The contrast curve is given on page 4. To avoid damaging of the circuit by flash-over pulses, picked-up by the leads, it is recommended that a capacitor of 100 nF be connected between this pin and earth.

6. Saturation control input

The control curve is given on page 4. To avoid damaging of the circuit by flash-over pulses, picked-up by the leads, it is recommended that a capacitor of 100 nF be connected between this pin and earth.

7. (B-Y) signal output

The amplitude of this signal is controlled by the contrast setting and the saturation setting simultaneously. At nominal contrast and nominal saturation setting an amplitude of 1.6 V peak-to-peak is obtained at an input amplitude of 0.9 V peak-to-peak. The average level is typically 6.1 V.

8. (B-Y) signal input

The signal has to be a. c. coupled to the input.

To cope with the variation of picture contents an input voltage margin of ± 0.8 V is provided, whereas the input signal has a typical value of ± 0.45 V for a saturated colour bar signal.

APPLICATION INFORMATION (continued)9. (R-Y) signal input

The signal has to be a.c. coupled to the input.

To cope with the variation of picture contents an input voltage margin of $\pm 0,8$ V is provided, whereas the input signal has a typical value of $\pm 0,35$ V for a saturated colour bar input.

10. (R-Y) signal output

The amplitude of this signal is controlled by the contrast setting and saturation setting simultaneously. At nominal contrast and nominal saturation setting an amplitude of 1,25 V peak-to-peak is obtained at an input amplitude of 0,7 V peak to peak.

The average level is typically 6,1 V.

11. (G-Y) signal input

The (G-Y) signal is obtained by matrixing a part of the (R-Y) and (B-Y) signals in a resistor network. The input may range from 1 to 6,5 V.

An average level of typical 5,9 V is required to produce an average output level of 6,1 V.

The gain of the inverter stage is typically 1.

12. (G-Y) signal output

An inverted signal with an amplitude of maximum 1 V peak-to-peak is available at this pin.

13. Supply voltage (12 V)

Correct operation occurs within the range 10,2 to 13,2 V.

The power dissipation must not exceed 600 mW at 65 °C ambient temperature.

14. Brightness control input

The black level of the luminance output signal tracks the potential applied to this pin. A typical value for setting the brightness control is 5,7 V, for which a black level of 4,2 V is obtained.

It is recommended that a capacitor of at least 10 μ F be connected between this pin and earth.

15. Black level clamp capacitor

The level of the back porch of the luminance output signal is stored in an external capacitor of about 0,68 μ F: the latter to be connected between pins 14 and 15.

16. Luminance signal input

A positive luminance signal of 0,7 mA peak-to-peak between black and white level drives the luminance amplifier.

A black level of about 0,3 mA is recommended. For a.c. coupling a bias resistor to the supply line is required to bias the amplifier properly.

The resistance depends on the signal amplitude e.g.: 15 k Ω is recommended for a input signal of 0,7 mA peak-to-peak.