

Silicon PNP Power Transistors

2SA1075 2SA1076

DESCRIPTION

- With MT-200 package
- Complement to type 2SC2525,2SC2526
- Fast switching speed
- Excellent safe operating area

APPLICATIONS

- High frequency power amplifiers
- Audio power amplifiers
- Switching regulators
- DC-DC converters

PINNING(see Fig.2)

PIN	DESCRIPTION
1	Base
2	Collector;connected to mounting base
3	Emitter

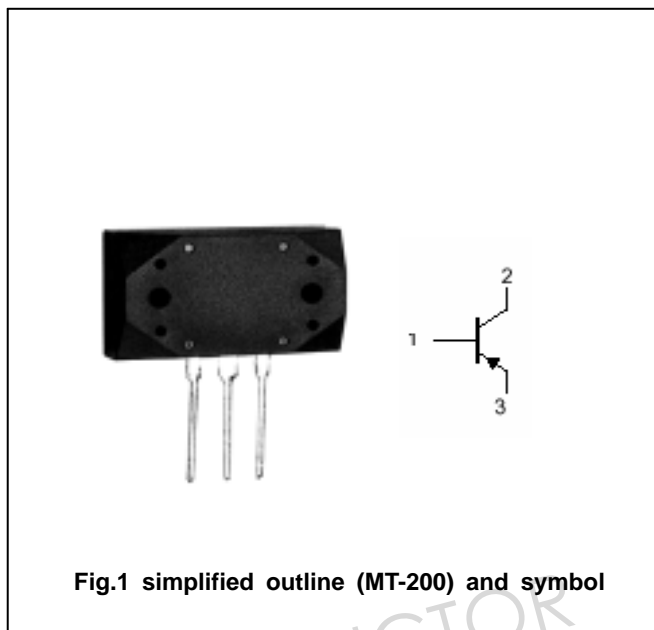

Fig.1 simplified outline (MT-200) and symbol

Absolute maximum ratings(Ta=25)

SYMBOL	PARAMETER	CONDITIONS	VALUE	UNIT
V _{CBO}	Collector-base voltage	2SA1075	-120	V
		2SA1076	-160	V
V _{CEO}	Collector-emitter voltage	2SA1075	-120	V
		2SA1076	-160	V
V _{EBO}	Emitter-base voltage	Open collector	-7	V
I _C	Collector current		-12	A
P _C	Collector power dissipation	T _C =25	120	W
T _j	Junction temperature		150	
T _{stg}	Storage temperature		-65~150	

Silicon PNP Power Transistors

2SA1075 2SA1076

CHARACTERISTICS

T_j=25 unless otherwise specified

SYMBOL	PARAMETER		CONDITIONS	MIN	TYP.	MAX	UNIT
V _{(BR)CEO}	Collector-emitter breakdown voltage	2SA1075	I _C =-1mA ; R _{BE} =	-120			V
		2SA1076		-160			
V _{(BR)CBO}	Collector-base breakdown voltage	2SA1075	I _C =-50 μ A ; I _E =0	-120			V
		2SA1076		-160			
V _{(BR)EBO}	Emitter-base breakdown voltage		I _E =-50 μ A ; I _C =0	-7			V
V _{CEsat}	Collector-emitter saturation voltage		I _C =-5A ; I _B =-0.5A			-1.8	V
V _{BE}	Base-emitter voltage		I _C =-5A ; V _{CE} =-5V			-1.7	V
I _{CBO}	Collector cut-off current	2SA1075	V _{CB} =-120V ; I _E =0			-50	μ A
		2SA1076	V _{CB} =-160V ; I _E =0				
I _{CEO}	Collector cut-off current	2SA1075	V _{CE} =-120V ; I _B =0			-1	mA
		2SA1076	V _{CE} =-160V ; I _B =0				
I _{EBO}	Emitter cut-off current		V _{EB} =-7V ; I _C =0			-50	μ A
h _{FE-1}	DC current gain		I _C =-1A ; V _{CE} =-5V	60		200	
h _{FE-2}	DC current gain		I _C =-7A ; V _{CE} =-5V	40			
C _{ob}	Output capacitance		I _E =0 ; V _{CB} =-10V		300		pF
f _T	Transition frequency		I _C =-1A ; V _{CE} =-10V		60		MHz

Switching times

t _r	Rise time	I _C =-7.5A ; R _L =4 I _{B1} =-I _{B2} =-0.75A		0.15		μ s
t _s	Storage time			0.50		μ s
t _f	Fall time			0.11		μ s

PACKAGE OUTLINE

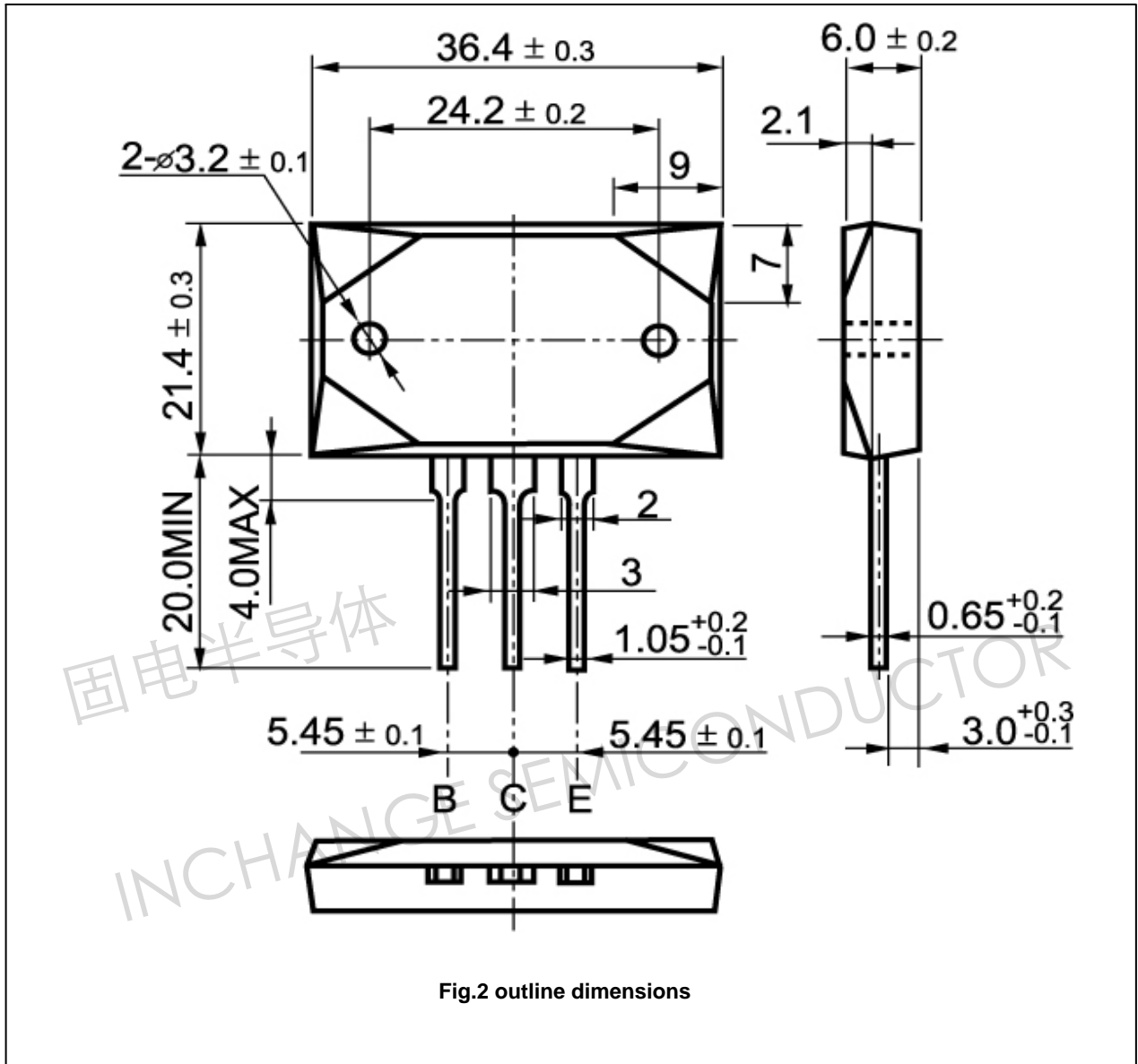

Fig.2 outline dimensions