

isc Silicon PNP Power Transistor

2SA1633

DESCRIPTION

- Collector-Emitter Breakdown Voltage-
 $V_{(BR)CEO} = -150V(\text{Min})$
- High Power Dissipation
- High Current Capacity
- Complement to Type 2SC4278

APPLICATIONS

- For audio and general purpose applications

ABSOLUTE MAXIMUM RATINGS($T_a=25^\circ\text{C}$)

SYMBOL	PARAMETER	VALUE	UNIT
V_{CBO}	Collector-Base Voltage	-150	V
V_{CEO}	Collector-Emitter Voltage	-150	V
V_{EBO}	Emitter-Base Voltage	-5	V
I_C	Collector Current-Continuous	-10	A
P_C	Collector Power Dissipation @ $T_C=25^\circ\text{C}$	100	W
T_J	Junction Temperature	150	$^\circ\text{C}$
T_{stg}	Storage Temperature Range	-55~150	$^\circ\text{C}$

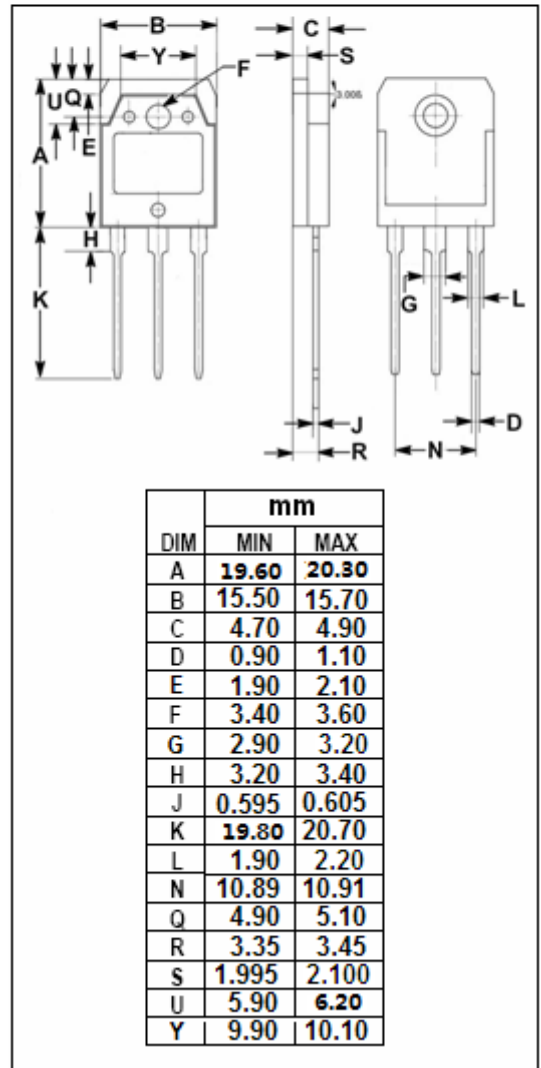
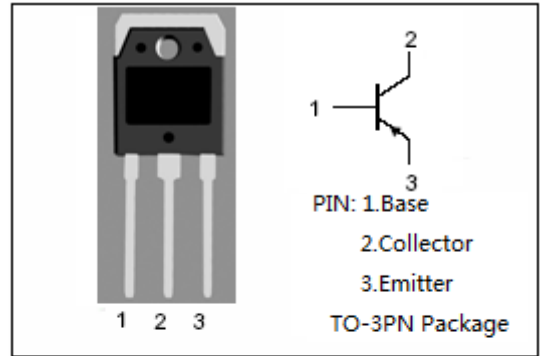

isc Silicon PNP Power Transistor**2SA1633****ELECTRICAL CHARACTERISTICS** $T_C=25^{\circ}\text{C}$ unless otherwise specified

SYMBOL	PARAMETER	CONDITIONS	MIN	TYP.	MAX	UNIT
$V_{(BR)CEO}$	Collector-Emitter Breakdown Voltage	$I_C = -25\text{mA}; I_B = 0$	-150			V
$V_{(BR)CBO}$	Collector-Base Breakdown Voltage	$I_C = -0.1\text{mA}; I_E = 0$	-150			V
$V_{(BR)EBO}$	Emitter-Base Breakdown Voltage	$I_E = -0.1\text{mA}; I_C = 0$	-5			V
$V_{CE(sat)}$	Collector-Emitter Saturation Voltage	$I_C = -7\text{A}; I_B = -0.7\text{A}$			-1.0	V
I_{CBO}	Collector Cutoff Current	$V_{CB} = -150\text{V}; I_E = 0$			-5	μA
I_{EBO}	Emitter Cutoff Current	$V_{EB} = -6\text{V}; I_C = 0$			-5	μA
h_{FE}	DC Current Gain	$I_C = -1\text{A}; V_{CE} = -5\text{V}$	60		320	
C_{OB}	Collector Output Capacitance	$I_E = 0; V_{CB} = -10\text{V}; f = 1\text{MHz}$		400		pF
f_T	Current-Gain—Bandwidth Product	$I_E = 1\text{A}; V_{CE} = -5\text{V}$		20		MHz

◆ **h_{FE} Classifications**

D	E	F
60-120	100-200	160-320