

Silicon NPN Power Transistors

2SC2023

DESCRIPTION

- With TO-220C package
- High breakdown voltage

APPLICATIONS

- Series regulator, switch, and general purpose applications

PINNING

PIN	DESCRIPTION
1	Base
2	Collector;connected to mounting base
3	Emitter

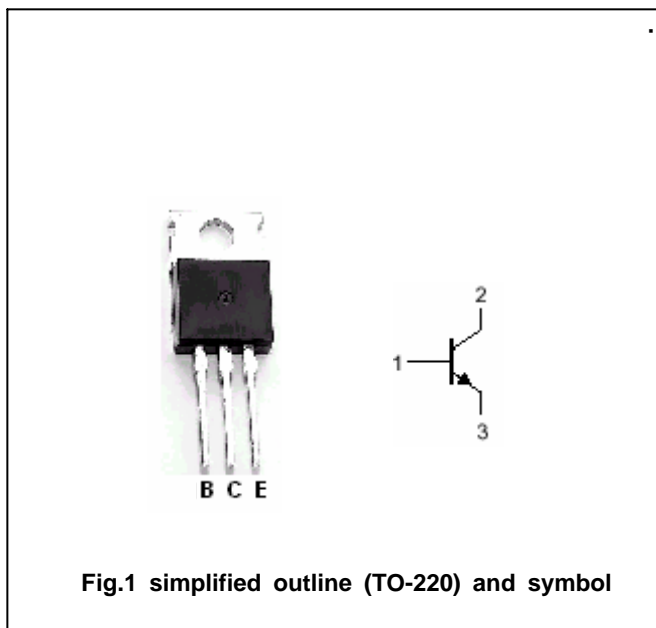

Absolute maximum ratings(Ta=25)

SYMBOL	PARAMETER	CONDITIONS	VALUE	UNIT
V_{CBO}	Collector-base voltage	Open emitter	300	V
V_{CEO}	Collector-emitter voltage	Open base	300	V
V_{EBO}	Emitter-base voltage	Open collector	6	V
I_C	Collector current		2	A
I_B	Base current		0.2	A
P_C	Collector dissipation	$T_C=25$	40	W
T_j	Junction temperature		150	
T_{stg}	Storage temperature		-50~150	

Silicon NPN Power Transistors

2SC2023

CHARACTERISTICS

T_j=25 unless otherwise specified

SYMBOL	PARAMETER	CONDITIONS	MIN	TYP.	MAX	UNIT
V _{(BR)CEO}	Collector-emitter breakdown voltage	I _C =25mA ; I _B =0	300			V
V _{CEsat}	Collector-emitter saturation voltage	I _C =1A; I _B =0.2A			1.0	V
I _{CBO}	Collector cut-off current	V _{CB} =300V ; I _E =0			1.0	mA
I _{EBO}	Emitter cut-off current	V _{EB} =6V; I _C =0			1.0	mA
h _{FE}	DC current gain	I _C =0.5 A ; V _{CE} =4V	30			
f _T	Transition frequency	I _C =0.2A ; V _{CE} =12V		10		MHz
C _{ob}	Collector output capacitance	f=1MHz ; V _{CB} =10V		75		pF

Switching times

t _{on}	Turn-on time	I _C =1A, I _{B1} =0.1A I _{B2} =-0.2A; V _{CC} =100V R _L =100		0.30		μs
t _s	Storage time			4.00		μs
t _f	Fall time			1.00		μs

PACKAGE OUTLINE

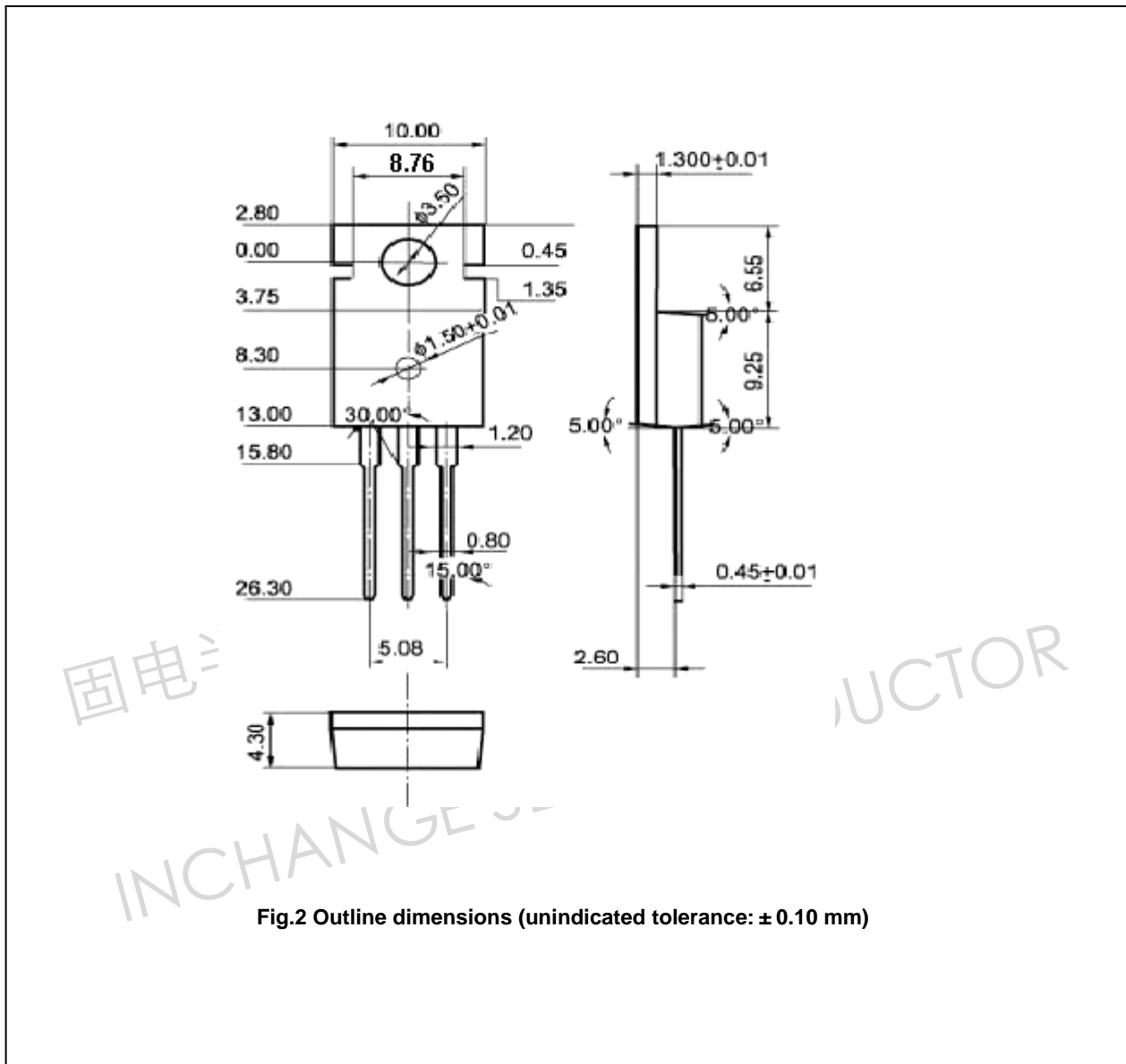

Fig.2 Outline dimensions (unindicated tolerance: ± 0.10 mm)