

Silicon NPN Darlington Power Transistor

2SD1769

DESCRIPTION

- High DC Current Gain-
: $h_{FE} = 2000(\text{Min}) @ I_C = 3A$
- Collector-Emitter Sustaining Voltage-
: $V_{CEO(\text{SUS})} = 120V(\text{Min})$
- Low Collector-Emitter Saturation Voltage-
: $V_{CE(\text{sat})} = 1.5V(\text{Max}) @ I_C = 3A$

APPLICATIONS

- Designed for solenoid driver, relay and motor, series regulator, and general purpose applications.

ABSOLUTE MAXIMUM RATINGS ($T_a = 25^\circ\text{C}$)

SYMBOL	PARAMETER	VALUE	UNIT
V_{CBO}	Collector-Base Voltage	120	V
V_{CEO}	Collector-Emitter Voltage	120	V
V_{EBO}	Emitter-Base Voltage	6	V
I_C	Collector Current-Continuous	6	A
I_{CM}	Collector Current-Peak	10	A
I_B	Base Current	1	A
P_C	Collector Power Dissipation $T_C = 25$	50	W
T_j	Junction Temperature	150	
T_{stg}	Storage Temperature Range	-55~150	

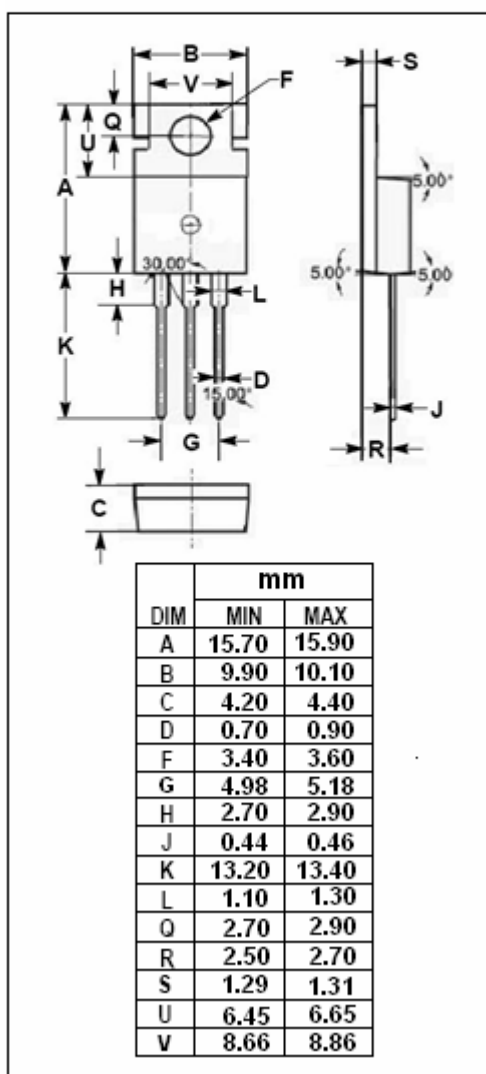
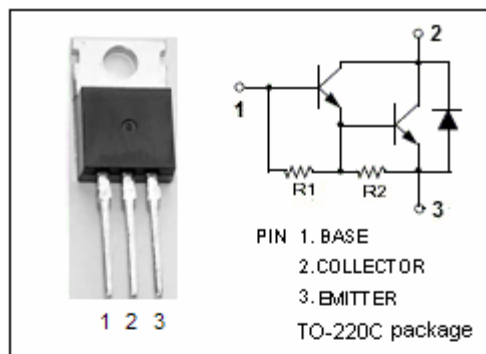

Silicon NPN Darlington Power Transistor

2SD1769

ELECTRICAL CHARACTERISTICS

 $T_C=25$ unless otherwise specified

SYMBOL	PARAMETER	CONDITIONS	MIN	TYP.	MAX	UNIT
$V_{(BR)CEO}$	Collector-Emitter Breakdown Voltage	$I_C=10mA, I_B=0$	120			V
$V_{CE(sat)}$	Collector-Emitter Saturation Voltage	$I_C=3A, I_B=3mA$			1.5	V
$V_{BE(sat)}$	Base-Emitter Saturation Voltage	$I_C=3A, I_B=3mA$			2.0	V
I_{CBO}	Collector Cutoff Current	$V_{CB}=120V, I_E=0$			10	μA
I_{EBO}	Emitter Cutoff Current	$V_{EB}=6V, I_C=0$			20	mA
h_{FE}	DC Current Gain	$I_C=3A, V_{CE}=2V$	2000			
f_T	Current-Gain—Bandwidth Product	$I_E=-0.2A, V_{CE}=12V$		100		MHz

Switching Times

t_{on}	Turn-on Time	$I_C=3A, R_L=10\Omega, I_{B1}=-I_{B2}=3mA, V_{CC}=30V$		0.5		μs
t_{stg}	Storage Time			5.5		μs
t_f	Fall Time			1.5		μs